

Contents

5211 PRINTER ATTACHMENT	9-1
INTRODUCTION	9-1
Circuit Locations	9-1
Printer Interface	9-1
DATA FLOW	9-2
FUNCTIONAL UNITS	9-3
OPERATIONS	9-13
Printer Commands	9-13
Example of Print Operations	9-14
Printing Operations	9-15
Spacing Operations	9-15
COMMANDS	9-16
I/O Load Command	9-16
I/O Control Load Command	9-18
I/O Sense Command-I/O Control Sense Command	9-20
Sense Interrupt Level Status Byte Command	9-22
Jump on I/O Command	9-24
ERROR CONDITIONS	9-26
INPUT/OUTPUT LINES	9-28
Hammer Interface Lines	9-28
Control Interface Lines	9-30
Operator Panel Interface Lines	9-31

This page intentionally left blank.



5211 Printer Attachment

INTRODUCTION

The 5211 printer attachment attaches the IBM 5211 Printer, either Model 1 or Model 2, to System/34. With the 48-character print belt, the Model 1 printer can operate at 160 lines per minute and the Model 2 printer can operate at 300 lines per minute.

Circuit Locations

Only two cards are used in System/34 for the printer attachment: a printer controller card located in A-A2S2 and a printer adapter card located in A-A2T2. The printer controller program performs most of the printer functions. These functions are:

- Print optioning
- Carriage movement and carriage synchronization
- Belt motion and belt synchronization
- Power on reset
- Error checking

Some of the functions performed by hardware on the adapter card are:

- Fire tier generation
- Hammer strobe generation
- Communications between the printer controller and the 5211 Printer
- Communications between the printer controller and the control processor

All communications between the control processor, the printer controller, the printer adapter, and the printer itself occur through the printer adapter card.

Printer Interface

The 5211 Printer attaches directly to the adapter card through a cable that contains three groups of interface lines. (See *Input/Output Lines* later in this section for a description of these lines.) The three groups of interface lines and their functions are:

- Hammer interface lines, which control the print hammers.
- Control interface lines, which control the belt, the carriage, and the paper clamp.
- Operator panel interface lines, which sense the switches and control the lights on the printer console.

In addition, the control and operator panel interfaces contain the lines that control the power in the printer.

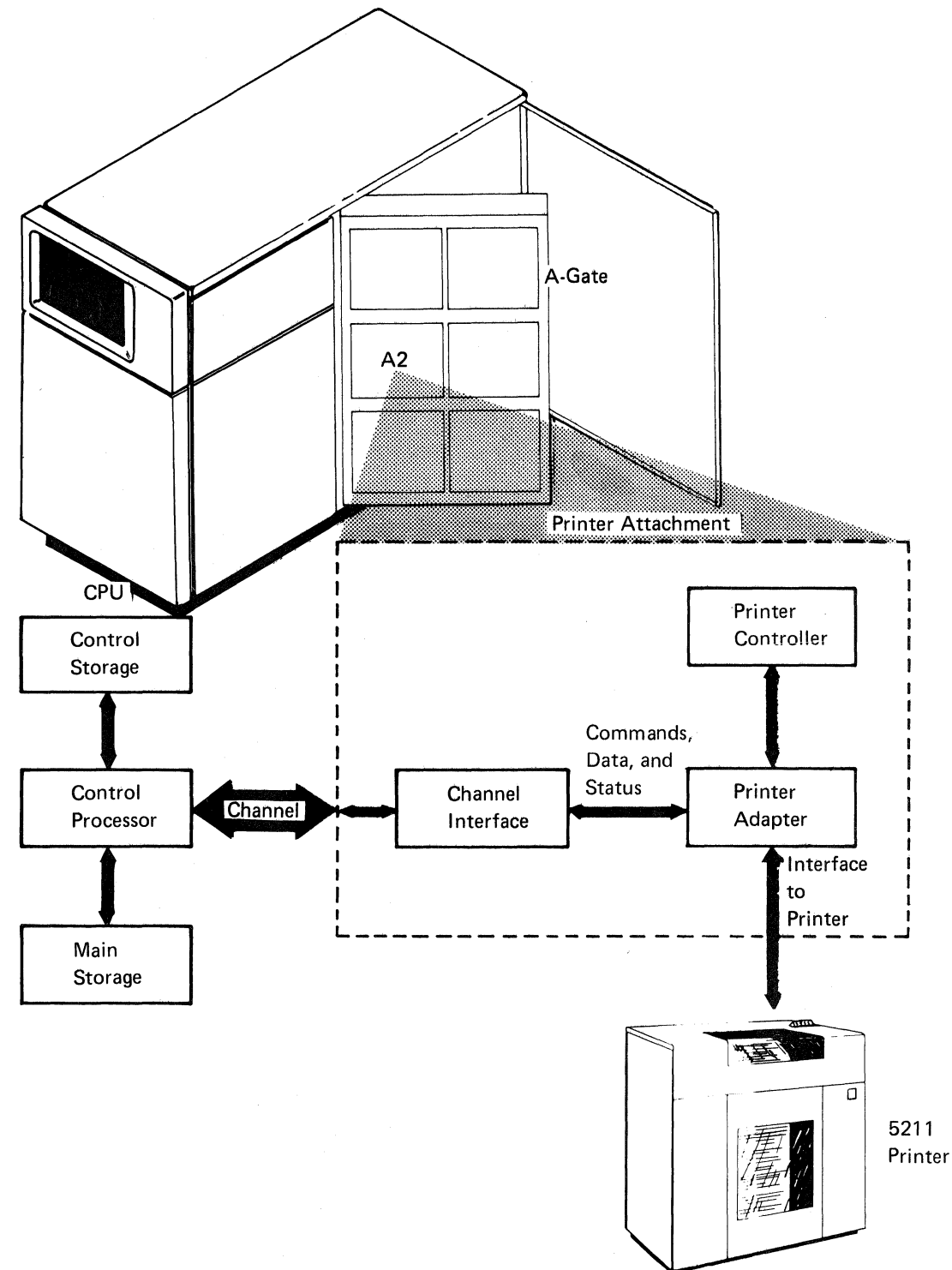

DATA FLOW

The functional units identified with an alphabetic character on this data flow figure are described under *Functional Units* and may be referenced in other places in this section.

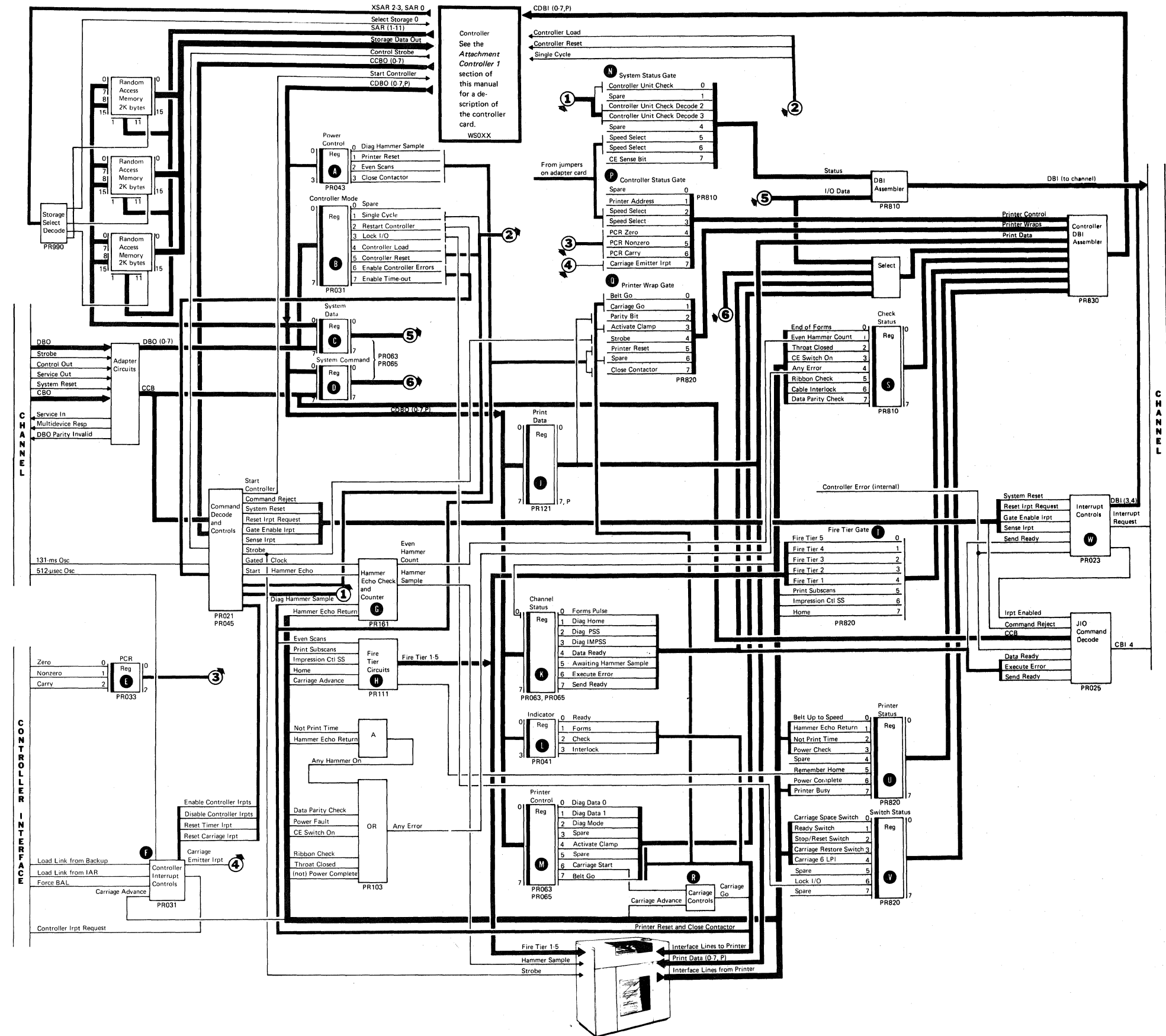

FUNCTIONAL UNITS

The data flow figure on the preceding page contains the functional units described below. Notice on the data flow figure that all registers are loaded either by controller DBO from the controller card, by DBO from the channel, or by the interface lines from the printer.

Power Control Register **A**

This 4-bit register controls the power in the 5211 Printer. The bit definitions are:

Bit 0 = Diagnostic hammer sample

Lets the controller generate 'hammer sample' pulses for failing hammer logging.

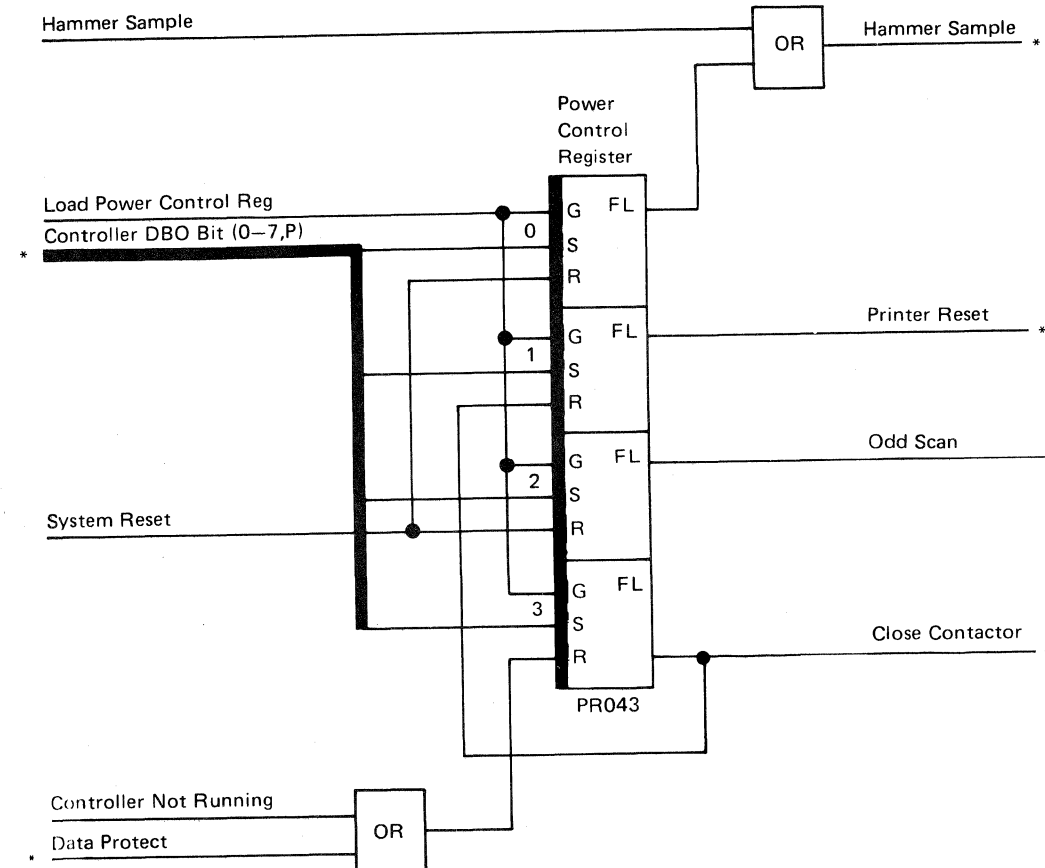

* Lines that can be probed

Bit 1 = Printer reset

Controls the 'power on reset' line to the printer.

Bit 2 = Even scans

Changes the fire tiers between odd and even scans (Model 1 printer only).

Bit 3 = Close contactor

Controls the 'close 25-Vdc contactor' line to the printer.

Controller Mode Register **B**

This 8-bit register is loaded by an I/O control load command. The register lets the controller control some of the functions of the printer attachment. These functions are:

Bit 0 = Spare

Bit 1 = Single cycle

Sets the controller to single-cycle mode.

Bit 2 = Controller restart

Resets the controller errors and forces the controller storage address register to hex 0000 for the next instruction cycle.

Bit 3 = Lock I/O

Informs the attachment that the control processor is ready to send an IOB and its associated data stream (through the channel) to the attachment. The printer controller must not start an operation that would delay the receiving of data.

Bit 4 = Printer controller load

Starts a controller load operation in the printer controller and lets System/34 load the attachment storage.

Bit 5 = Controller reset

Disables controller errors.

Bit 6 = Enable parity errors

Enables sensing of controller parity errors (status byte 0, bit 0).

Bit 7 = Enable time-out

Enables a 131-millisecond timer. If the microcode is in a loop for more than 131 milliseconds, a controller unit check (status byte 0, bit 0) is generated because a time-out occurs. To prevent time-outs, the controller must reset the timer.

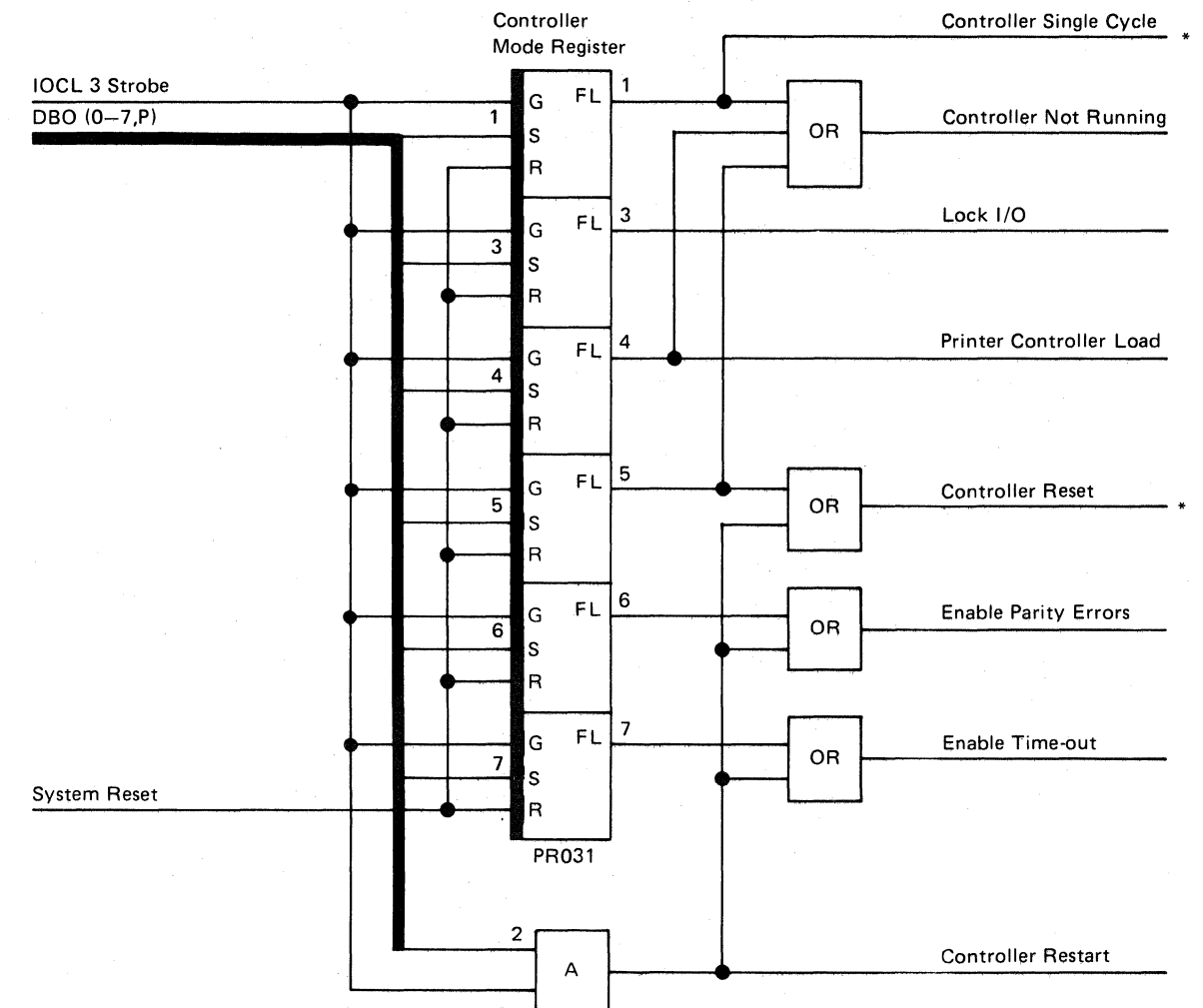

* = Lines that can be probed

System Data Register C

This 8-bit register is loaded by an I/O load or I/O control load instruction. It can be sensed by the controller to determine the DBO contents. The controller can also load this register to be sensed later by the control processor using an I/O sense instruction.

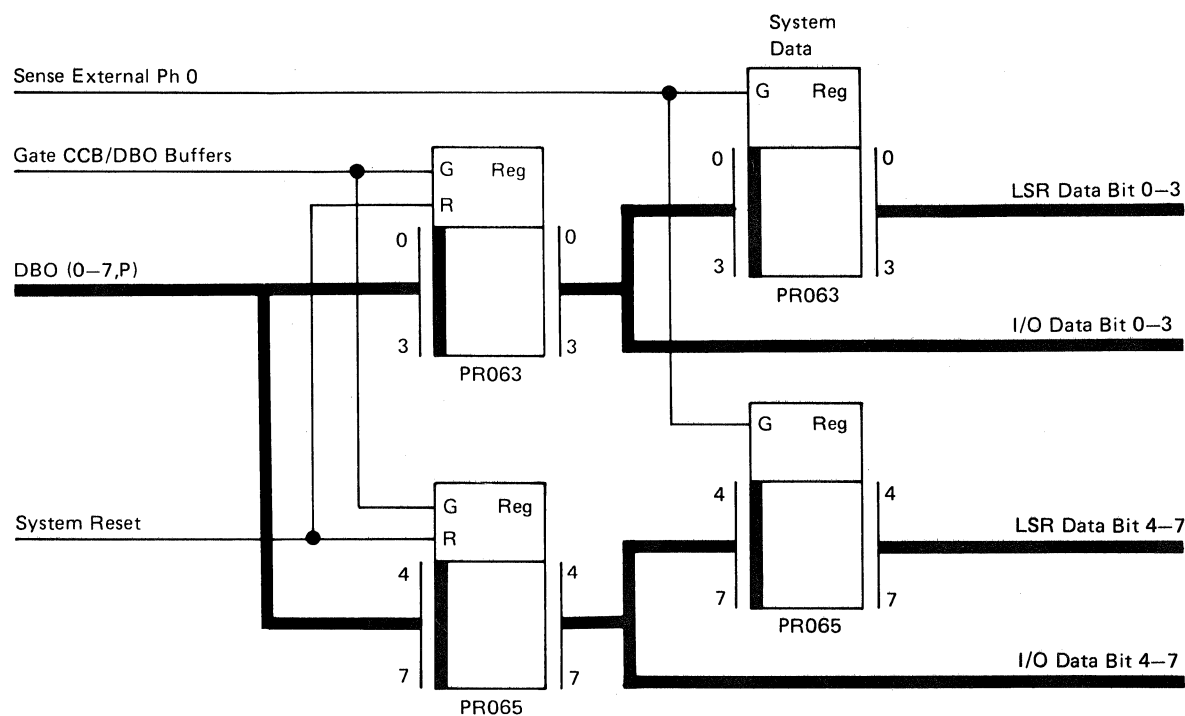

System Command Register D

This 8-bit register is loaded by CCB during a system I/O instruction. CCB is generated from DBO bits 4 through 7 and by CBO bits 0 and 1. The command register can also be loaded by the controller from controller DBO for diagnostic purposes.

Bit 0 (command to the controller) indicates that an I/O instruction has been received. Bit 3 (data ready) is not generated from the CCB; it is generated by the attachment to inform the system that a byte of data is loaded in the system data register and is ready to be sensed. After the system data register is sensed, the data ready bit is reset.

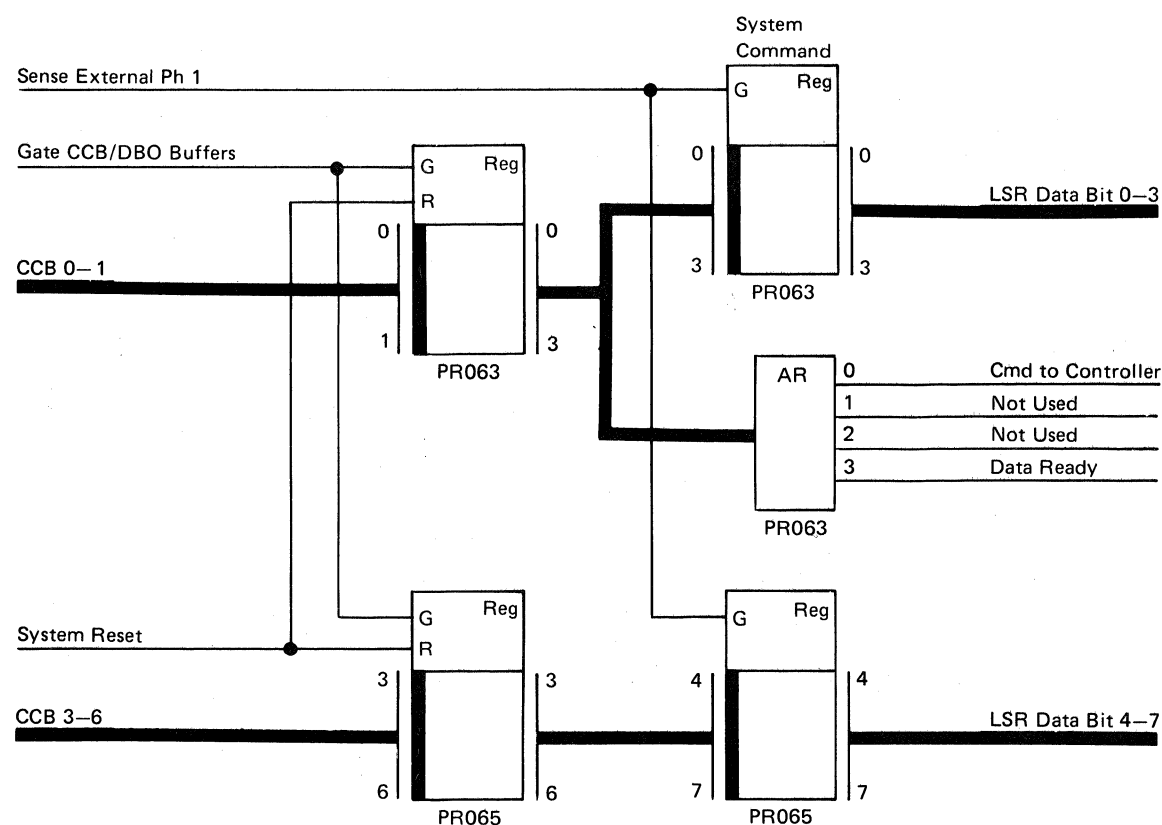

Processor Condition Register (PCR) E

This 3-bit register, representing three controller conditions, is loaded by hardware when an interrupt occurs. The three controller conditions (zero, nonzero, and carry) are kept in this register for later use by the interrupt handler before continuing the interrupted routine. The bit definitions are:

- Bit 0 = Zero
- Bit 1 = Nonzero
- Bit 2 = Carry

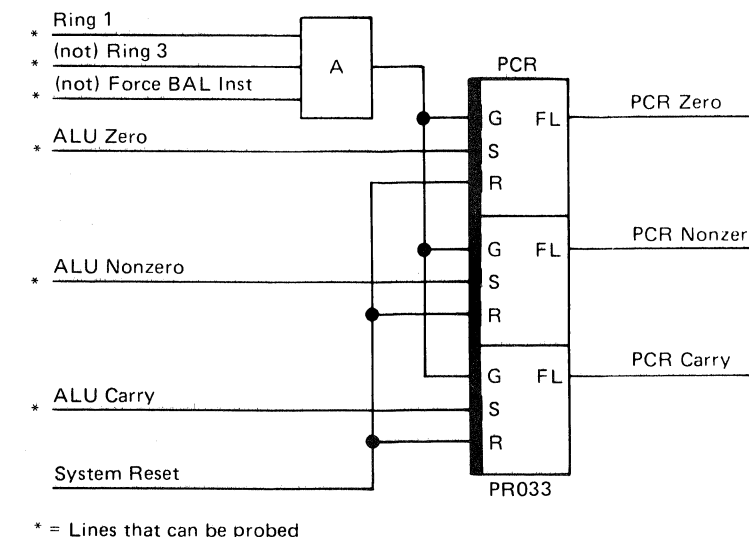

* = Lines that can be probed

Controller Interrupt Controls **F**

Both the 512-microsecond timer from the controller and the carriage emitter pulses (the 'carriage advance' line from the printer) interrupt the controller. The interrupts are reset or can be disabled by the controller.

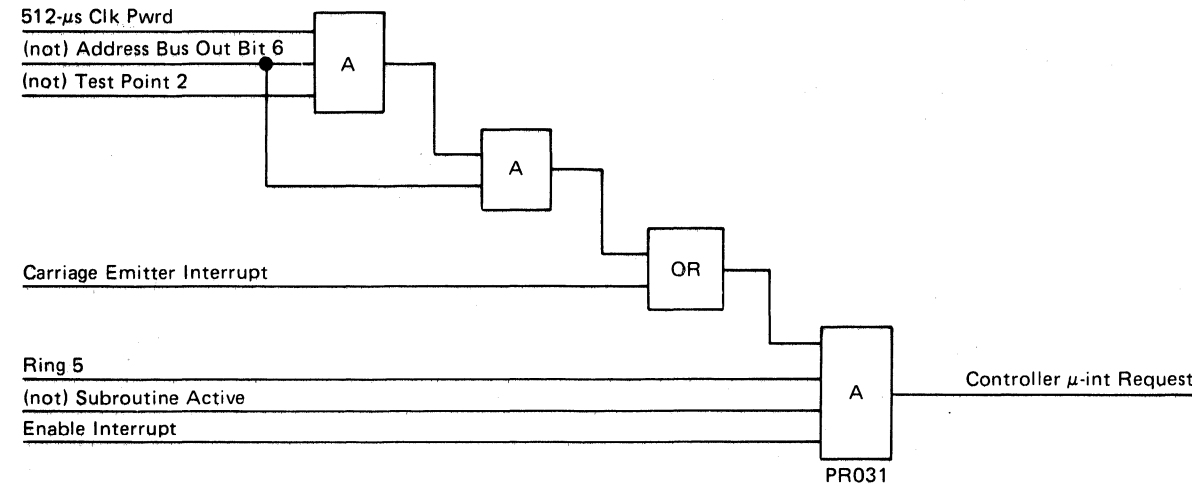

Hammer Echo Check and Counter **G**

The hammer echo circuits include two parts: the hammer sample generator and the hammer echo counter. The hammer sample generator generates 134 pulses 20 microseconds after the fall of the 'impression ctl SS' line or the rise of the 'print subscans' line, whichever occurs last. These pulses are sent to the printer on the 'hammer sample' line.

The hammer echo counter counts the number of pulses returned on the 'hammer echo return' line from the printer. The low-order bit of the hammer echo counter supplies hammer parity. (See *Hammer Sample and Hammer Echo Return* later in this section for descriptions of these two interface lines.)

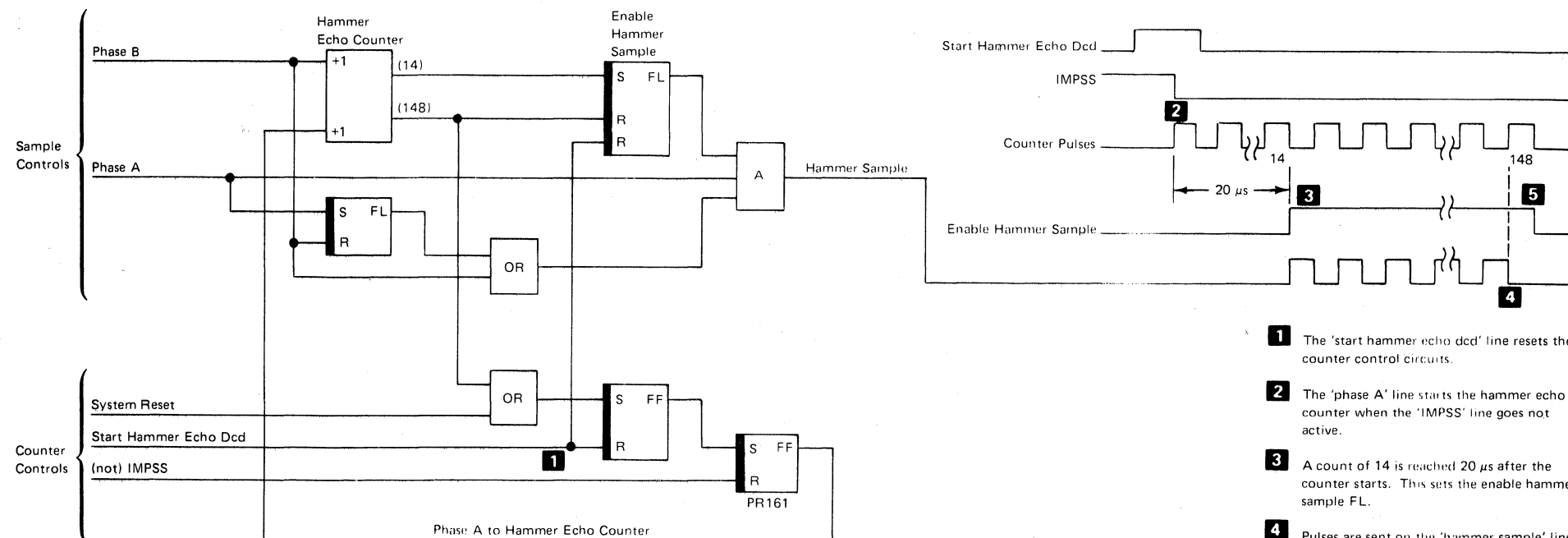

- 1** The 'start hammer echo dcd' line resets the counter control circuits.
- 2** The 'phase A' line starts the hammer echo counter when the 'IMPSS' line goes not active.
- 3** A count of 14 is reached 20 µs after the counter starts. This sets the enable hammer sample FL.
- 4** Pulses are sent on the 'hammer sample' line until a count of 148 is reached.
- 5** A count of 148 resets the enable hammer sample FL and sets the counter control circuits. The counter control circuits reset the counter to 0.

Fire Tier Circuits H

These circuits generate the five fire tier lines that determine when optioned print hammers are to be fired. Three interface lines from the printer and one line from the adapter generate the fire tier lines; they are the 'home', 'print subscans', and 'impression ctl SS' lines from the printer, and the 'odd scan' line from the power control register in the adapter. For a timing diagram of the fire tier generation, see *Control Interface Lines* later in this section.

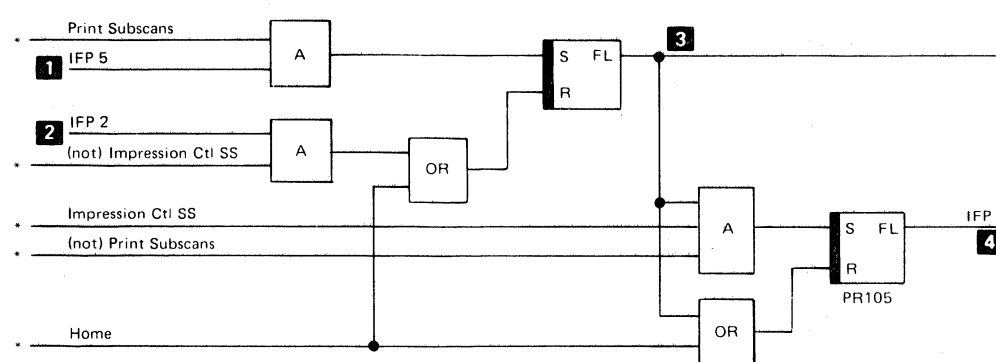

Only the IFP (internal fire pulse) circuit for fire pulse 1 is shown here. There is a similar circuit for fire pulse 2 through fire pulse 5; for these circuits, the following table gives the line names for the inputs at 1 and 2, the line names for the outputs at 3 and 4, and the FSL page where the IFP circuit can be found.

Circuit	1	2	3	4	FSL Page
IFP2	IFP1	IFP3	Fire pulse 2	IFP2	PR106
IFP3	IFP2	IFP4	Fire pulse 3	IFP3	PR107
IFP4	IFP3	IFP5	Fire pulse 4	IFP4	PR108
IFP5	IFP4	IFP1	Fire pulse 5	IFP5	PR109

* = Lines that can be probed

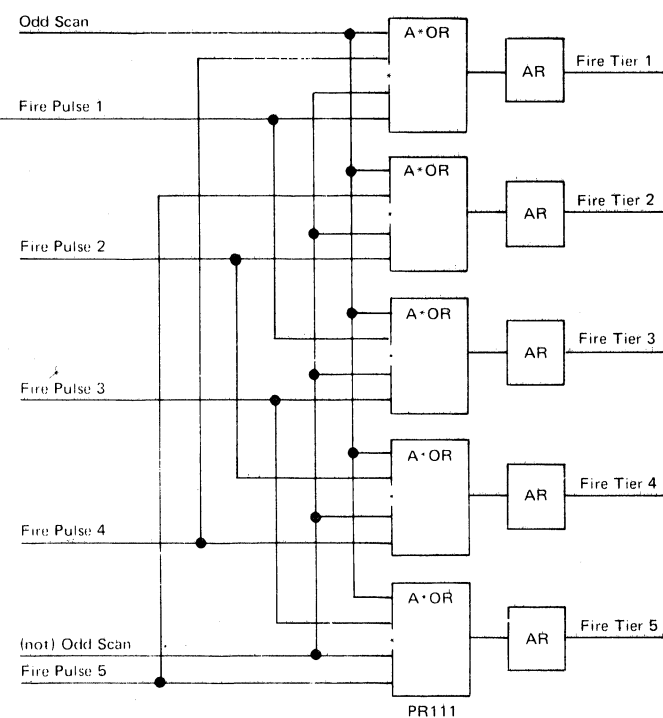

Print Data Register I

This 9-bit register (print data bits 0 through 7 and parity), which is loaded only by the controller, sends print hammer information to the printer. The contents of this register can be sensed by the controller for diagnostic purposes. (See *Hammer Interface Lines* later in this section for bit definitions.)

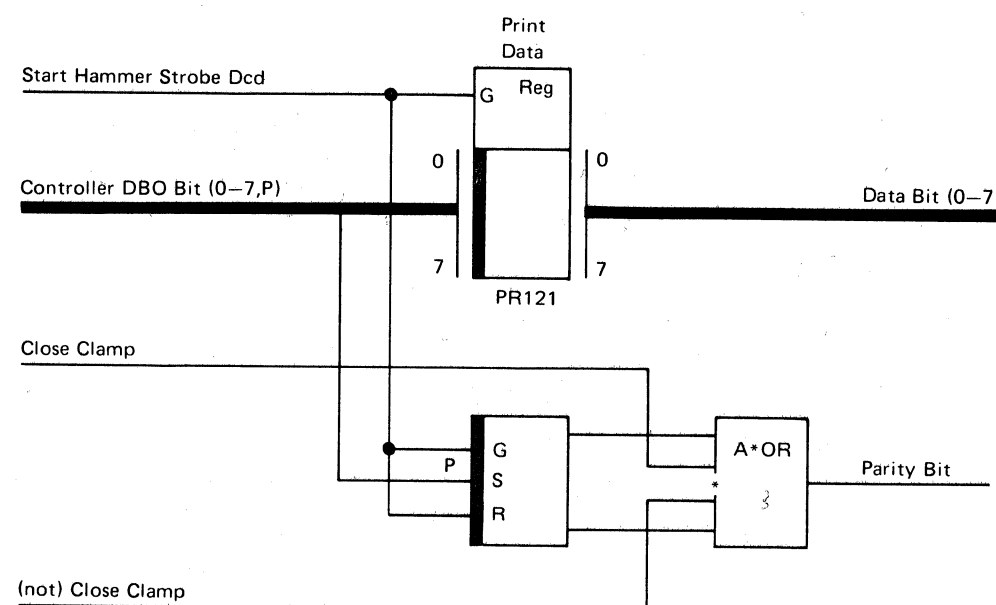

* = Lines that can be probed

Channel Status Register K

This 8-bit register is loaded and sensed by the controller. The bit definitions are:

Bit 0 = Forms pulse

The signal from the printer indicates that a forms pulse occurred during carriage motion.

Bit 1 = Diagnostic home

Bit 2 = Diagnostic print subs cans

Bit 3 = Diagnostic impression control singleshot

Note: Bits 1 through 3 are similar to the respective printer lines when running diagnostics.

Bit 4 = Data ready

Bit 5 = Awaiting hammer sample

The controller uses this bit to determine when hammer echo checking is complete.

Bit 6 = Execute error

Set by the attachment to inform the system that an error occurred when attempting to perform an operation.

Bit 7 = Send ready

Set by the attachment to inform the system that the controller is ready to service additional commands from the system, or that an error occurred. This bit causes an interrupt in the system.

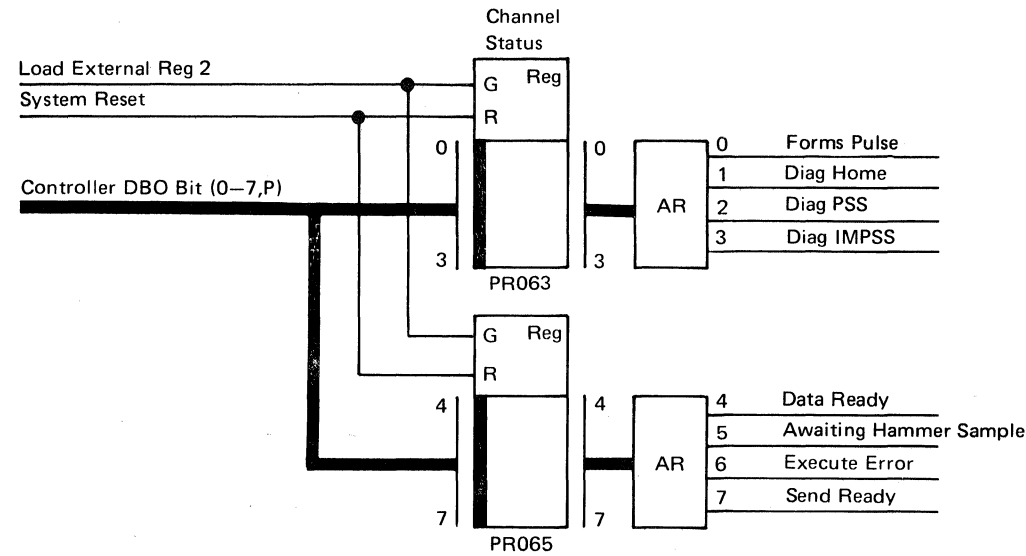

Indicator Register L

The controller uses this 4-bit register to control the lights on the 5211 Printer operator panel. The bit definitions for the four lights are:

Bit 0 = Ready

Bit 1 = Forms

Bit 2 = Check

Bit 3 = Interlock

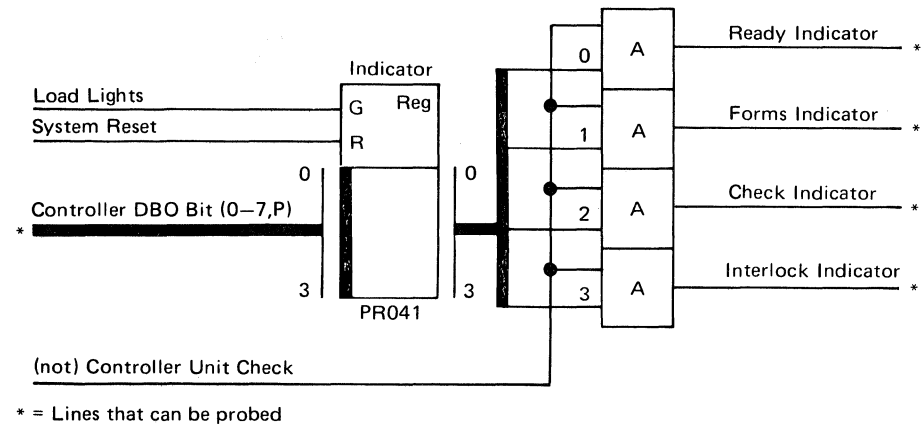

Printer Control Register M

This 8-bit register is loaded and sensed by the controller. The bit definitions are:

Bit 0 = Diagnostic data bit 0

Bit 1 = Diagnostic data bit 1

Bit 2 = Diagnostic mode

Note: Bits 0 through 2 are used to diagnose problems relative to the printer attachment hardware.

Bit 3 = Not used

Bit 4 = Activate clamp

Set by the controller to close the paper clamp on the printer. Printing does not start until the clamp is closed.

Bit 5 = Not used

Bit 6 = Carriage start

Used by the controller to control the 'carriage go' line to the printer.

Bit 7 = Belt go

Used by the controller to activate the belt motor on the printer.

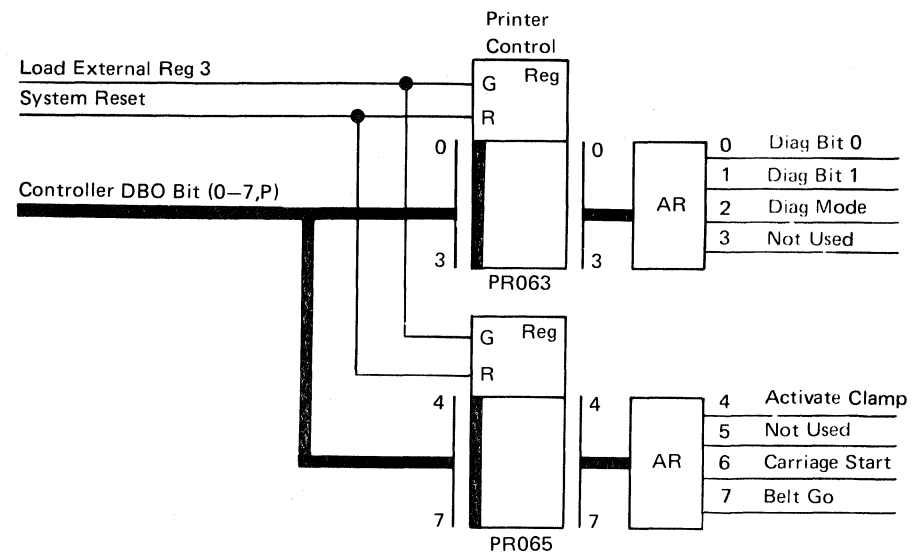

System Status Gate N

This 8-bit gate is used during an I/O control sense instruction. The bit definitions are:

Bit 0 = Controller unit checks

Indicates that a controller time-out or a hardware parity check occurred.

Bit 1 = Not used

Bits 2 and 3 = Controller unit check decode

These 2 bits are valid if bit 0 is on; they are encoded as follows:

00 = Time-out error

01, 10, or 11 = Hardware parity check

Bit 4 = Not used

Bits 5 and 6 = Speed select jumper status

00 and 10 = Jumpers not correctly placed on the adapter card

01 = Jumpers for 300 lines-per-minute printer

11 = Jumpers for 160 lines-per-minute printer

Note: These bits are the same as bits 2 and 3 of the controller status gate, but they are inverted.

Bit 7 = CE sense bit

Controller Status Gate P

This 8-bit gate helps determine controller conditions. The bit definitions are:

Bit 0 = Not used

Bit 1 = Printer address

Indicates the printer address is hex E0.

Bits 2 and 3 = Speed select

00 = Jumpers for 160 lines-per-minute printer

01 and 11 = Jumpers not correctly placed on the adapter card

10 = Jumpers for 300 lines-per-minute printer

Bit 4 = Zero condition from PCR register

Bit 5 = Nonzero condition from PCR register

Bit 6 = Carry condition from PCR register

Bit 7 = Carriage emitter interrupt

Indicates that a carriage interrupt occurred.

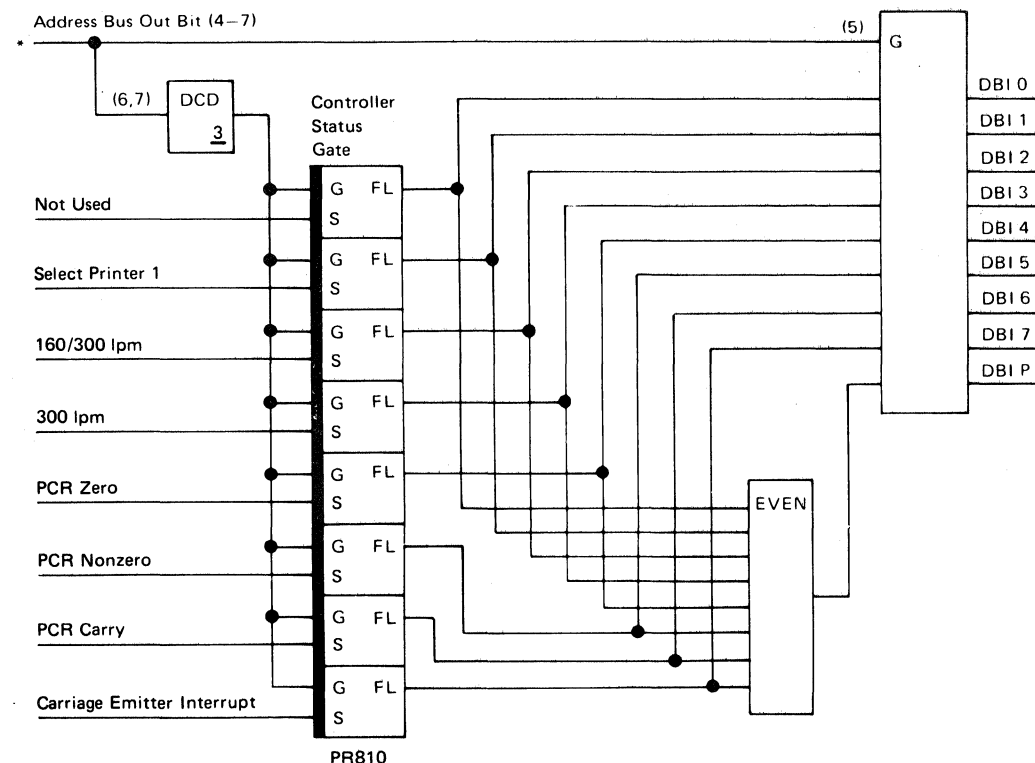

* = Lines that can be probed

Printer Wrap Gate Q

The controller uses this gate to sense printer control signals. The gate is used mainly for diagnostic purposes. The bit definitions are:

Bit 0 = Belt go

Bit 1 = Carriage go

Bit 2 = Print data parity bit (from the print data register)

Bit 3 = Activate clamp

Bit 4 = Print data strobe

Bit 5 = (not) Printer reset

Bit 6 = Not used

Bit 7 = Close contactor

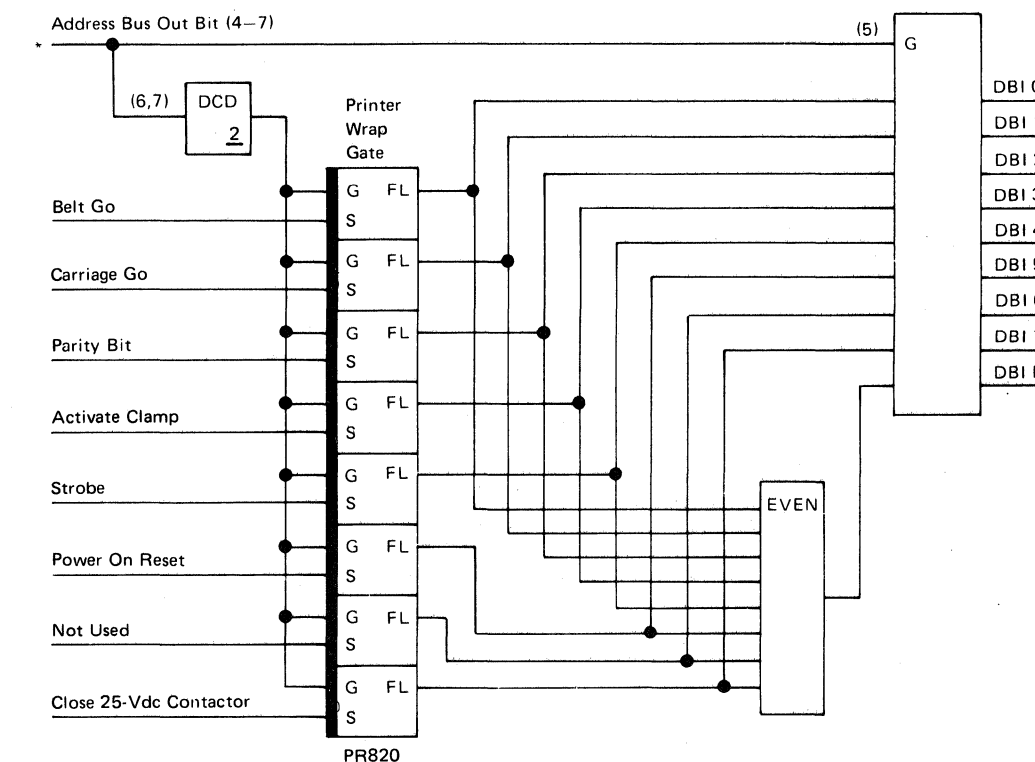

* = Lines that can be probed

Carriage Controls **R**

This circuit turns off the 'carriage go' line on the leading edge of a 'carriage advance' pulse. To better understand the relationship of the 'carriage go' line to the 'carriage advance' pulse, see *Carriage Go and Carriage Advance* later in this section.

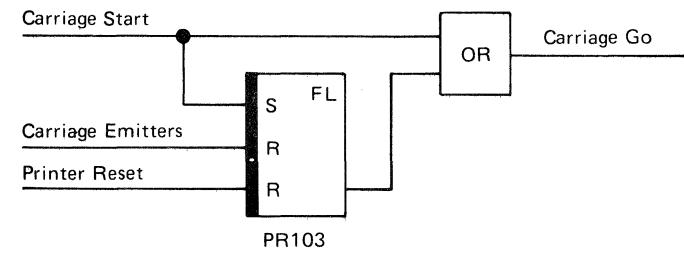

* = Lines that can be probed

Check Status Register **S**

This 8-bit register is sensed by the controller to sample some of the printer interface lines. The bit definitions are:

Bit 0 = (not) End-of-forms

Indicates the status of the end-of-forms switch on the 5211 Printer.

Bit 1 = Even hammer count

Senses the hammer parity generated by counting the 'hammer echo return' pulses.

Bit 2 = Throat closed

Indicates the position of the throat on the 5211 Printer.

Bit 3 = CE switch on

Indicates that any CE switch on the 5211 Printer is on.

Bit 4 = Any error

Indicates if any of the following errors have occurred:

- Power on not complete
- Power fault

- Throat open

- Any hammer on

- Print data parity error

- Ribbon check

- A CE switch on the 5211 Printer is on

Print optioning ends if any of these errors occur.

Bit 5 = Ribbon check

Indicates that the ribbon speed was too slow.

Bit 6 = Cable interlock

If this bit is off, the cables with cable interlocks are seated correctly. If this bit is on, one or more of the cables are not seated correctly.

Bit 7 = Data parity check

Indicates if bad print data parity was received at the printer.

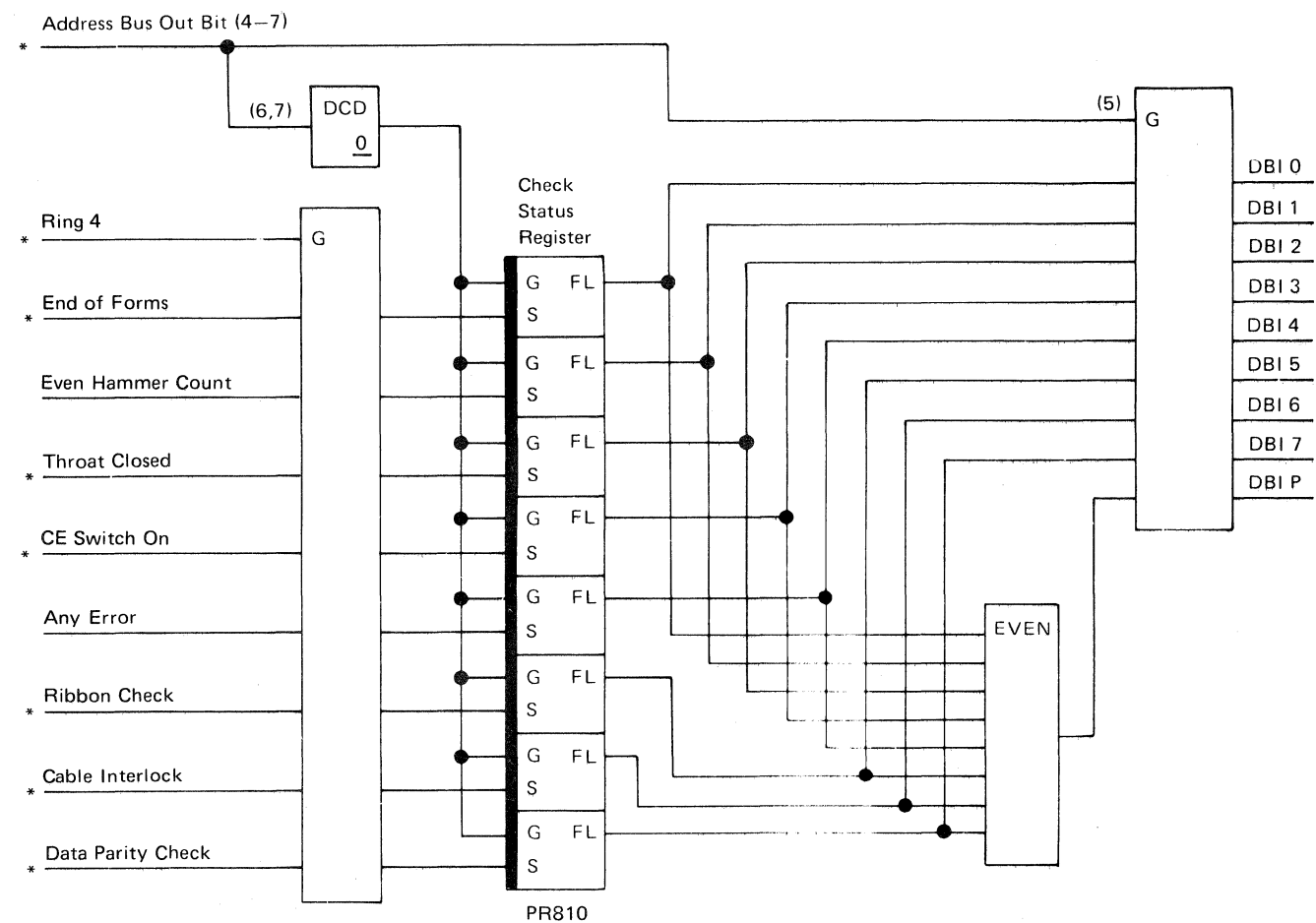

* = Lines that can be probed

Fire Tier Gate

The controller uses this 8-bit gate to sense the 'print subscans', 'impression ctl SS', and 'home' signals, or to determine the state of the fire tier lines. The bit definitions are:

- Bit 0 = Fire tier 5
- Bit 1 = Fire tier 4
- Bit 2 = Fire tier 3
- Bit 3 = Fire tier 2
- Bit 4 = Fire tier 1

Note: The fire tier lines help establish and maintain belt synchronization. Sent to the controller on controller DBI (CDBI), these lines let the controller determine the current print subscan and, therefore, determine when the hammers are to be fired. They also determine the length of time the hammers are fired. The controller checks these lines for the proper fire tier sequence. Wrong fire tier sequence can cause a fire tier check or print subscan emitter check. For fire tier sequence, see *Control Interface Lines* later in this section.

Bit 5 = Print subscans

Maintains belt synchronization during print optioning.

Bit 6 = Impression control singleshot

Bit 7 = Home

Note: Bits 5 through 7 are from the printer; they are described later in this section under *Input/Output Lines*.

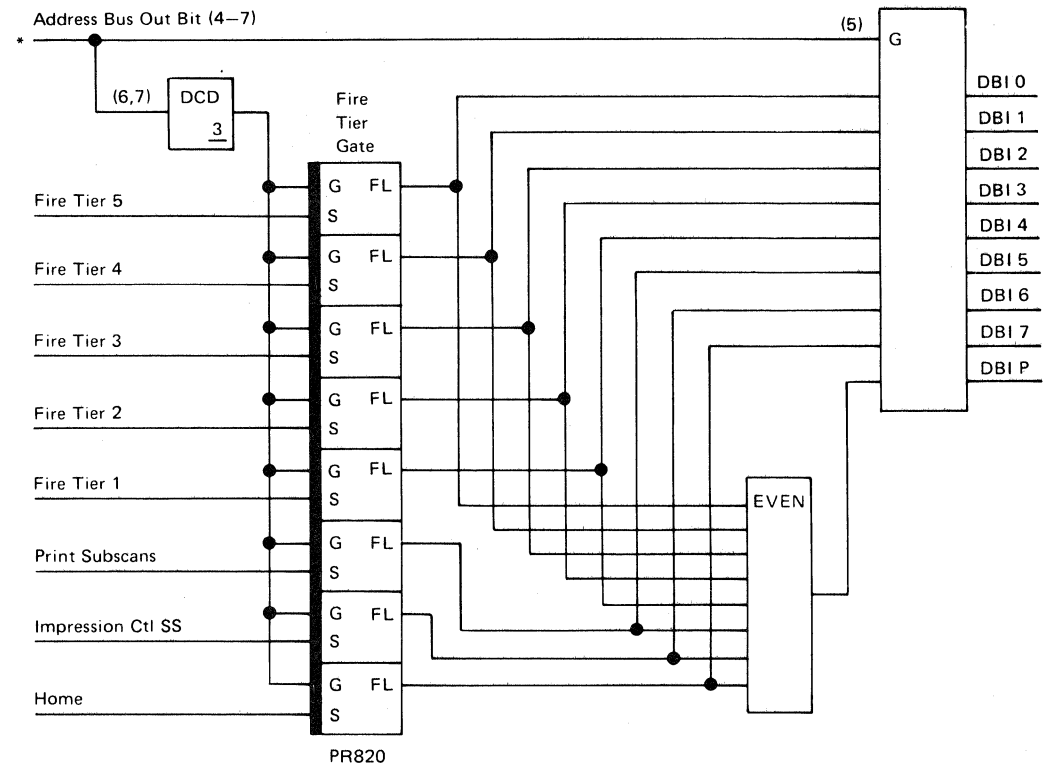

* = Lines that can be probed

Printer Status Register

This 8-bit register is sensed by the controller to determine the status of some printer interface lines. The bit definitions for these printer interface lines are:

Bit 0 = Belt up to speed

Indicates the print belt is running at the correct speed.

Bit 1 = Hammer echo return

Indicates an any-hammer-on check if the 'not print time' and the 'hammer echo return' lines are active at the same time. When the 'not print time' line is not active, this bit indicates the state of the hammer (0 = off and 1 = on) as sampled by the 'hammer sample' line.

Bit 2 = Not print time

Bit 3 = Power check

Bit 4 = Not used

Bit 5 = Remember home

Generated for each 'home' pulse from the printer, and remains active for four of the five print subscans to aid in sensing the 'home' pulse.

Bit 6 = (not) Power complete

Bit 7 = Printer busy

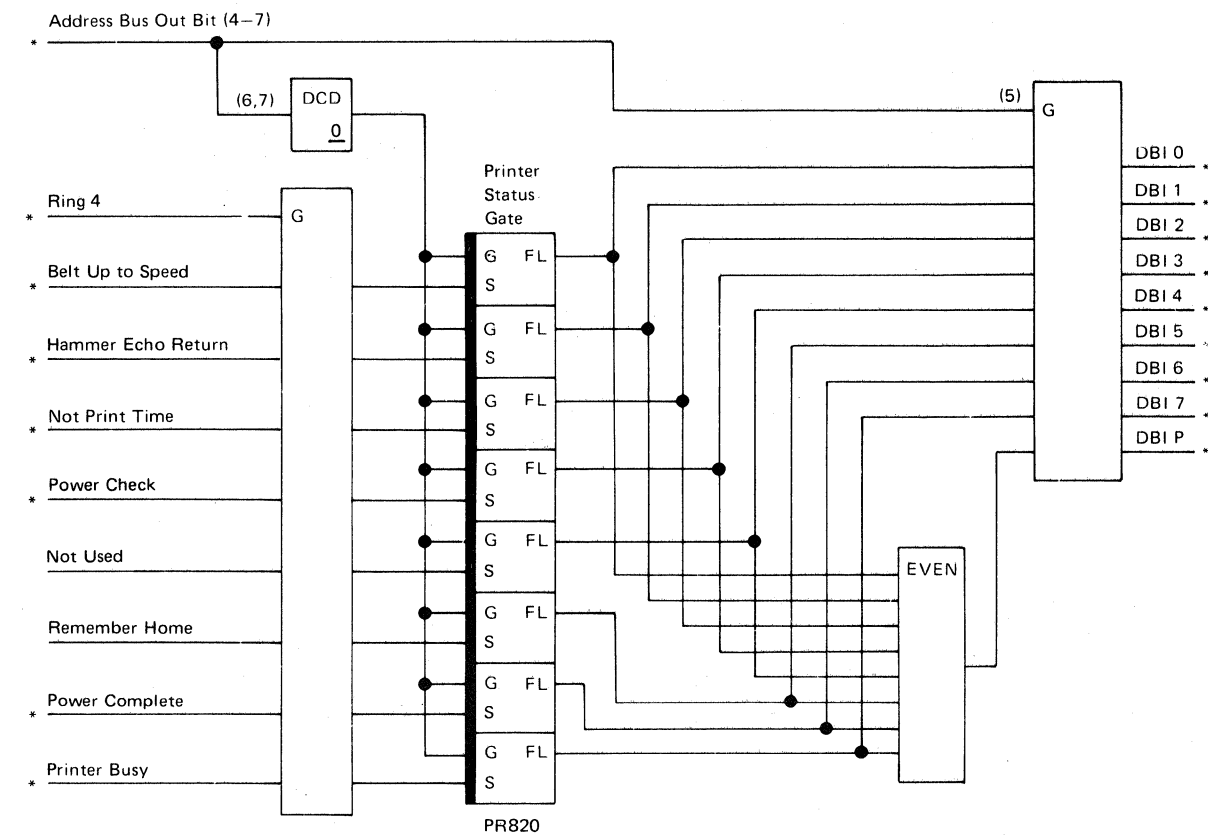

* = Lines that can be probed

Switch Status Register V

This 8-bit register is sensed by the controller to determine the status of the 5211 Printer switches and the 'lock I/O' signal from the system. The bit definitions are:

Bit 0 = Carriage Space switch

Bit 1 = Ready switch

Bit 2 = Stop/Reset switch

Bit 3 = Carriage Restore switch

Bit 4 = Carriage 6 lpi

Indicates if the printer is operating at 6 or 8 lines per inch.

Bit 5 = Not used

Bit 6 = Lock I/O (from the system)

Bit 7 = Not used

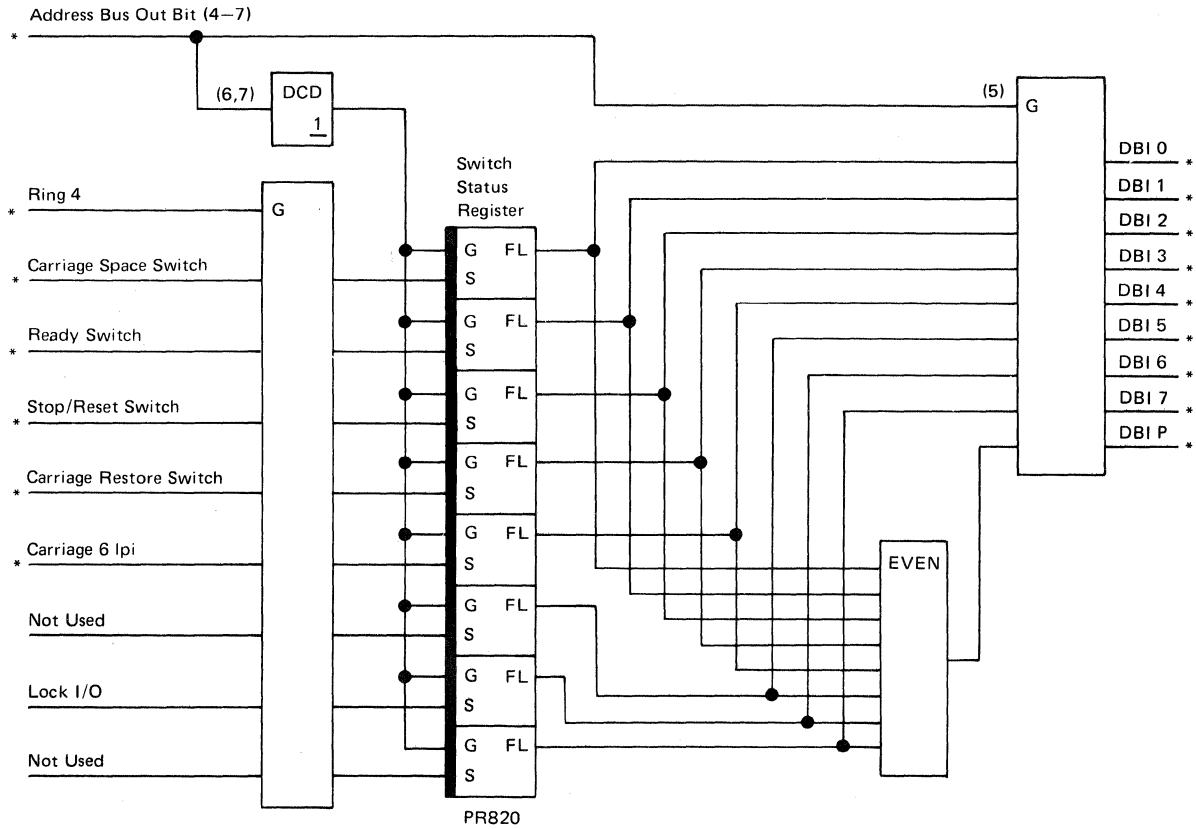

* = Lines that can be probed

Interrupt Controls W

This circuit supplies an interrupt to the system as a result of a 'send ready' signal. It also supplies a response to the system on a sense interrupt level status byte (SILSB) command.

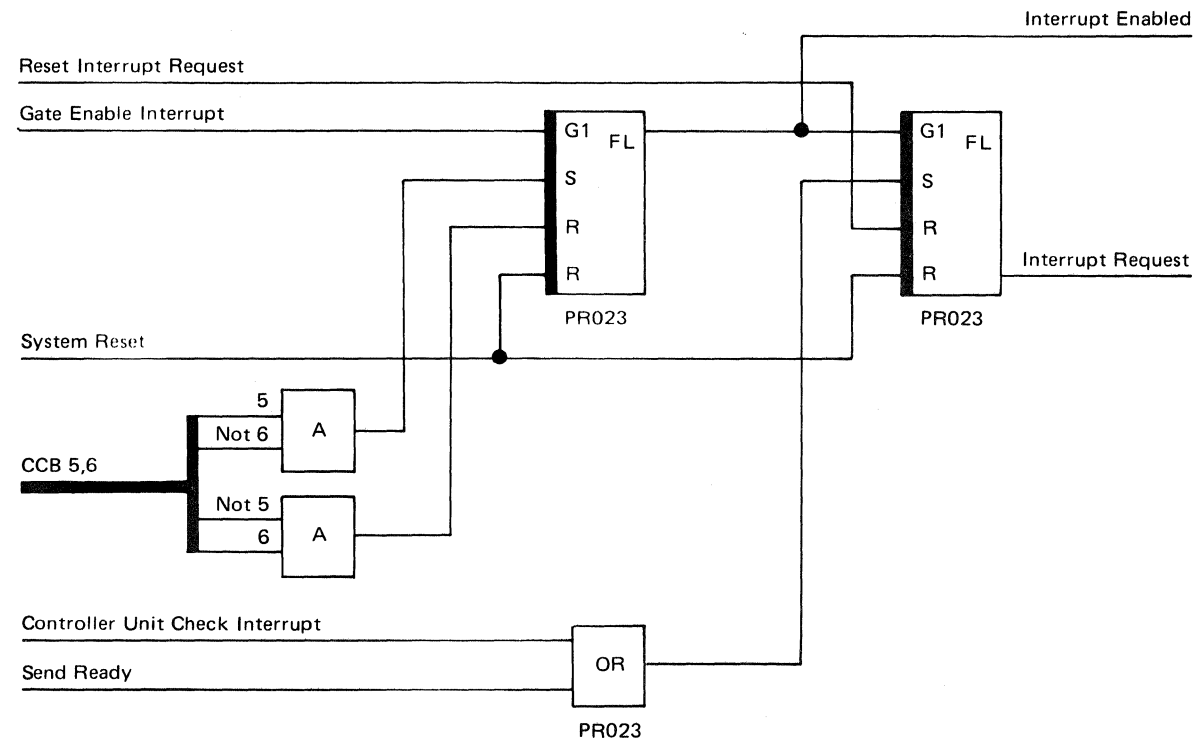

This page intentionally left blank.



OPERATIONS

All printer operations are controlled by a set of commands that are sent to the printer controller through an output data stream from the work station data management (WSDM) routine.

In addition to containing the commands (also known as control characters) for the printer, the output data stream (1) contains all the print data, carriage control information, and formatting information, (2) is limited to 256 bytes because this is the size of the printer receive buffers, and (3) contains free-form information (free-form in the sense that commands can appear at random in the data stream).

For each data transfer, the sequence of events is:

1. Issue start of transmission
2. Send command code
3. Receive accumulated line count
4. Send command modifier
5. Send data length count (2 bytes)
6. Send data
7. Issue end of transmission

Printer Commands

Commands are distinguished from print data in the output data stream because print data characters have hexadecimal values from 40 to FF and commands (control characters) have hexadecimal values from 00 to 3F. There are only five valid hexadecimal values for the control characters: 0C, 0D, 15, 2B, and 34.

Note: The control characters and the parameter bytes that follow the control characters in the output data stream make up the printer commands. However, for purposes of the descriptions of the commands, the control characters are sometimes referred to as *the command*.

In the following command descriptions, the hexadecimal value of each command (control character) is given in parentheses after the name of the command. Several terms used in the descriptions are:

Left margin: The first print position of each line.

Presentation position: Where printing occurs next after an executable command.

Maximum presentation position: The last print position of each line.

Maximum presentation line: The last line of the form that is equal to the forms length. The forms length can be equal to any number from 1 to 255 and must be set by the set vertical format command. If the forms length is not set, the forms length defaults to a value of 1.

For additional information on these commands, see Chapter 5 of the *Functions Reference Manual*.

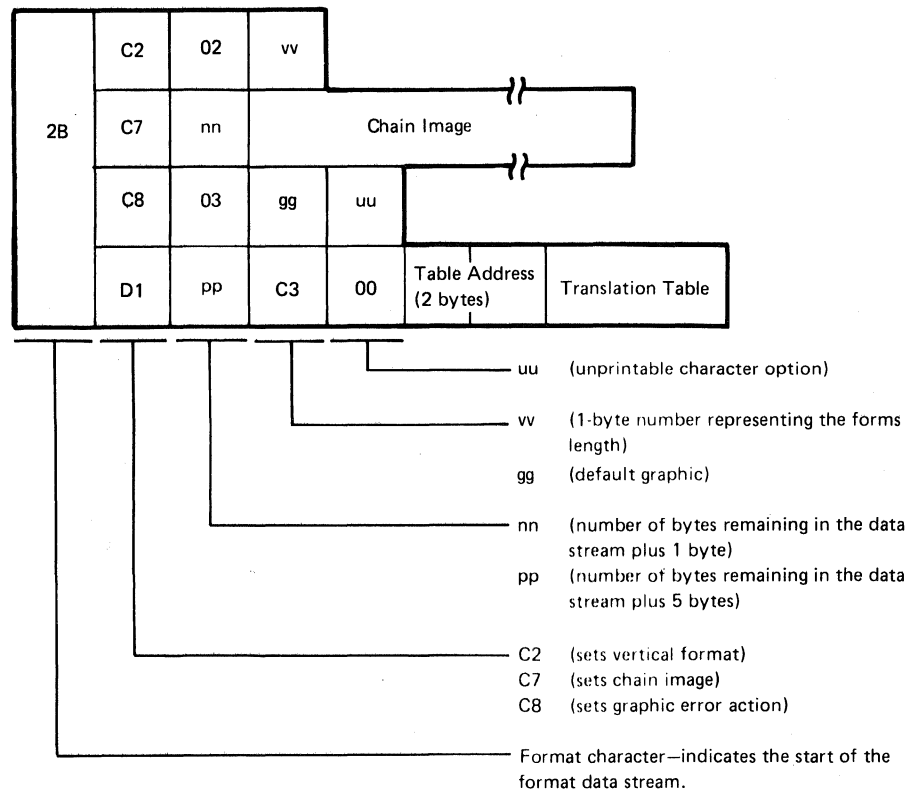

Forms Feed (0C)

This is a forms eject command that advances the forms to line 1 and print position 1 of the next form.

Carriage Return (0D)

This command moves the presentation position to the left margin of the same line. If the current presentation position is equal to the left margin, the function becomes a no-op.

New Line (15)

This command moves the presentation position to the left margin of the next line. An automatic new line command is executed if a sequence of print characters causes the presentation position to go beyond 132 (the maximum presentation position).

Format (2B)

This command sets the forms length, specifies the action to be taken when an unprintable character is sensed in the data stream, or specifies a new belt image. The format character (hex 2B) by itself gives just the starting position of a format data stream. It is followed by one of four parameters (hex C2 for set vertical format, hex C7 for set chain image, hex C8 for set graphic error action or hex D1 for set translation table), a count byte, and other bytes as shown in the following figure.

Presentation Position (34)

This command moves the presentation position as instructed by one of the following function parameters:

- Relative vertical position (hex 4C)
- Absolute vertical position (hex C4)
- Relative horizontal position (hex C8)

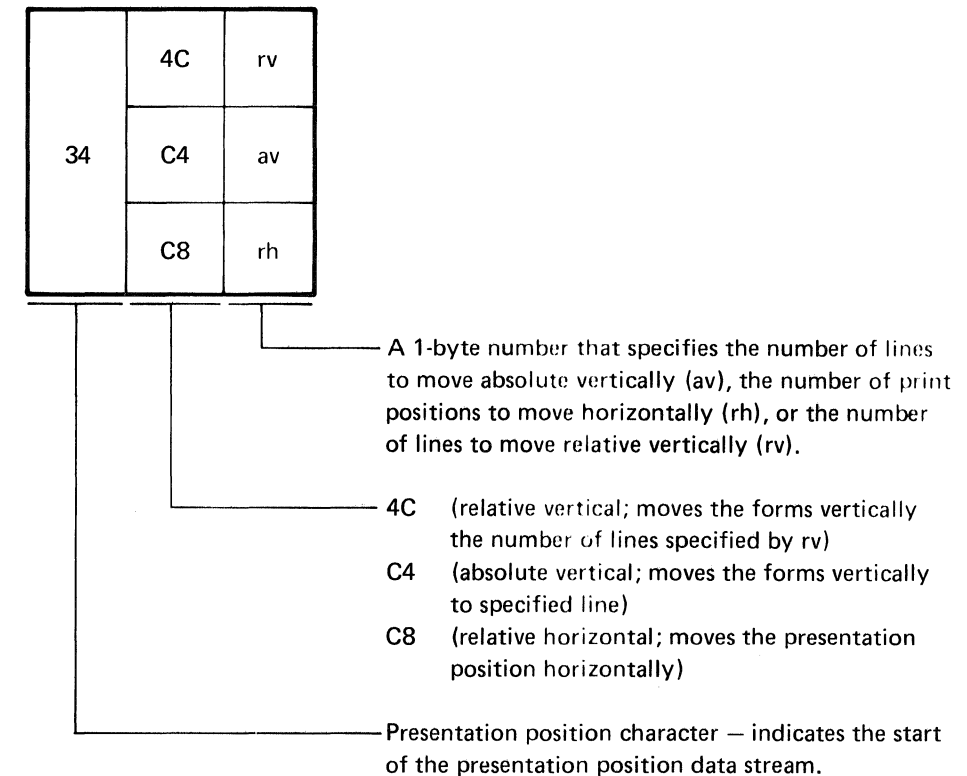

The function parameter follows the command character (hex 34) in the data stream.

A value parameter follows the function parameter in the data stream; it is a 1-byte count that specifies the line to be moved to vertically, the number of lines to move vertically, or the number of print positions to move horizontally. The value parameter is valid for an absolute vertical move if the number is equal to or less than the maximum presentation line (or the forms length). The value parameter is valid for a relative vertical move if the number is equal to or less than the remaining number of lines on the page. It is valid on a horizontal move if the number specifies a move to, but not past, the end of the line (maximum presentation position). The format for this command is shown in the following figure.

Example of Print Operations

The figure on this page is divided into three main sections: main storage, control storage, and printer controller storage. The main storage section shows a 256-byte main storage buffer loaded with 54 bytes of control and print information.

There are 12 parts (12 print operations) to the main storage buffer shown here, and each part has an associated alphabetic character. Match the alphabetic character on this figure with the alphabetic character shown on the facing page for a description of the print operation.

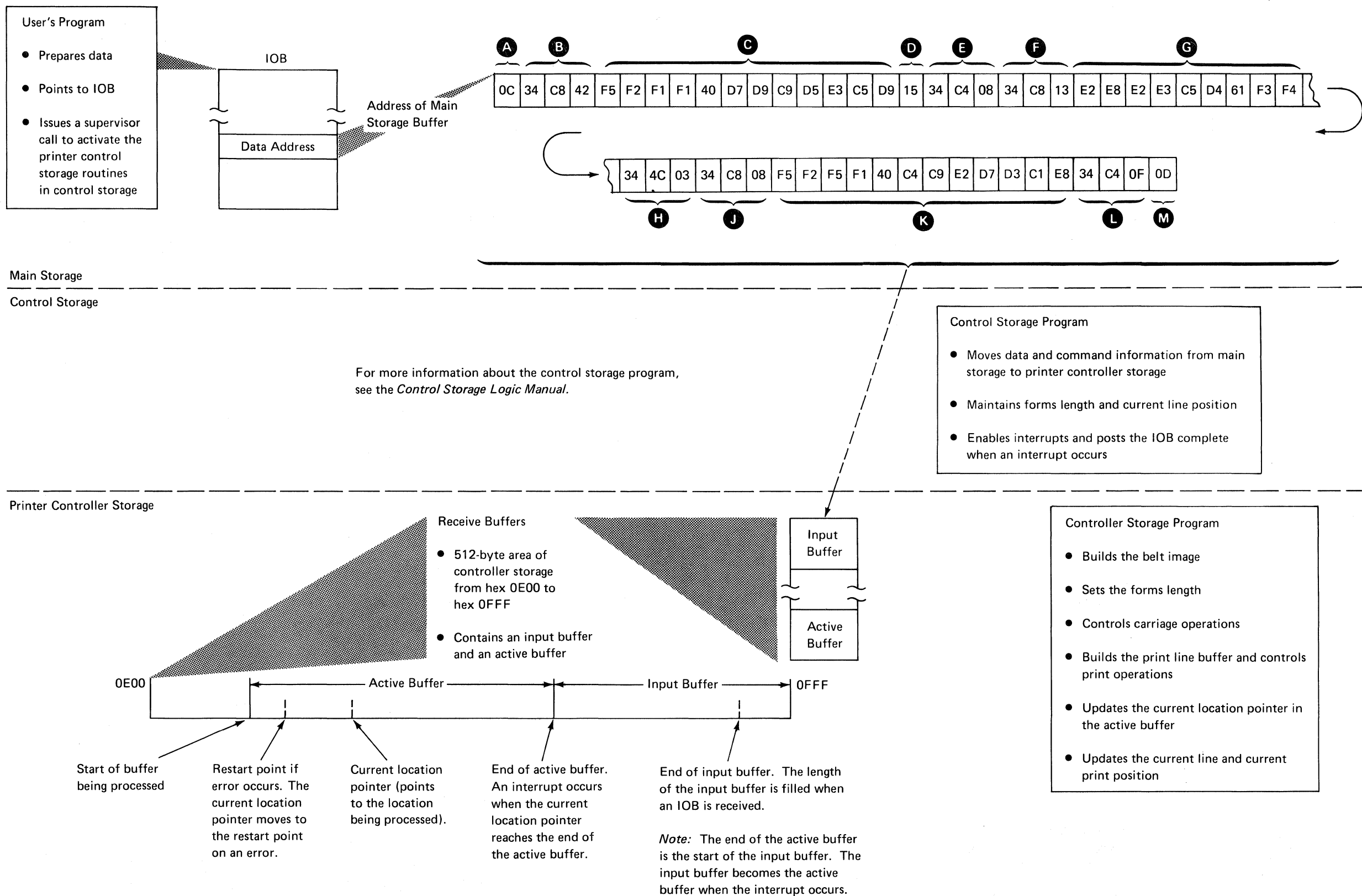

The examples of the print operations shown on these two pages assume that the forms length and the belt image have already been set. Notice that the first operation starts on page 11 (in the figure on this page); it is a forms feed command **A** that moves the print position from page 11 to the first print position of page 12.

Printing Operations

Three printing operations are shown in the figure at right. The operations are marked as **C**, **G**, and **K**. The characters to be printed for any printing operation are sent by the channel to the printer controller via an I/O load command (1001). The characters are stored in controller storage until the transfer of the IOB is complete.

When the transfer of the IOB is complete, the controller microcode examines the characters and determines at which print position the characters are to be printed. Also, the microcode keeps track of the belt position so that when the character to be printed is in front of the proper print hammer, the microcode can cause the proper hammer to be *optioned*. A hammer is *optioned* by turning on the correct data bits [see *Data Bits (0-7, P)* under *Input/Output Lines* later in this section]. In turn, the data bits are clocked to the printer when the 'strobe' line from the printer attachment is active.

The printer attachment also generates 5 fire tier pulses based on the condition of the 'home', 'print subscans', and impression ctl SS' lines from the printer. (See *Control Interface Lines* under *Input/Output Lines* later in this section for a description of these three lines from the printer.) The optioned hammers are fired during the next active fire tier pulse; that is, if a hammer is optioned during fire tier 1, the hammer is not fired until fire tier 2.

Spacing Operations

For all spacing operations, a spacing-type command is sent by the channel to the controller via an I/O load command (1001). The command is stored in controller storage until the transfer of the IOB is complete.

When the transfer of the IOB is complete, the controller microcode examines the command and determines how many lines are to be skipped. In order for the microcode to be able to determine how many lines are to be skipped, a current line counter is maintained by the control storage program. By maintaining a current line counter, the number of lines skipped could be different for the same command.

For example, if a skip-to-line-20 command is issued and the printer is at line 1, the printer controller will cause the printer to skip 19 lines. However, if the printer is at line 15, the printer controller will cause the printer to skip only 5 lines.

Having determined how many lines are to be skipped, the microcode activates the 'carriage go' line to the printer, and the printer attachment monitors the 'carriage advance' line from the printer. Then, the microcode counts the number of emitter pulses on the 'carriage advance' line until it is determined that the correct number of lines have been skipped. Finally, the microcode de-activates the 'carriage go' line and causes the printer attachment to monitor the 'carriage advance' line for 3 more pulses. When these 3 pulses (deceleration pulses) are received, the spacing operation is complete.

- A** Forms feed (hex 0C): Moves the print position to the first position of the next logical page. (For purposes of this example, the first position is print position 1 of line 1.)
- B** Relative horizontal position (hex 34C8): Moves the print position 66 print positions (parameter of hex 42 in the command) to print position 67.
- C** Data: 5211 PRINTER
- D** New line (hex 15): Moves the print position to the first position of the next line (line 2, print position 1).
- E** Absolute vertical position (hex 34C4): Moves the print position 6 lines (parameter of hex 08 in the command) to line 8.
- F** Relative horizontal position (hex 34C8): Moves the print position 19 print positions (parameter of hex 13 in the command) to print position 20.
- G** Data: SYSTEM/34
- H** Relative vertical position (hex 3340): Moves the print position 3 lines (parameter of hex 03 in the command) to line 11. The print position is now on line 11, print position 29.
- J** Relative horizontal position (hex 34C8): Moves the print position 8 print positions (parameter of hex 08 in the command) to print position 37.
- K** Data: 5251 DISPLAY
- L** Absolute vertical position (hex 34C4): Moves the print position 4 lines (parameter of hex 0F in the command) to line 15.
- M** Carriage return (hex 0D): Moves the print position to print position 1 of the same line (line 15).

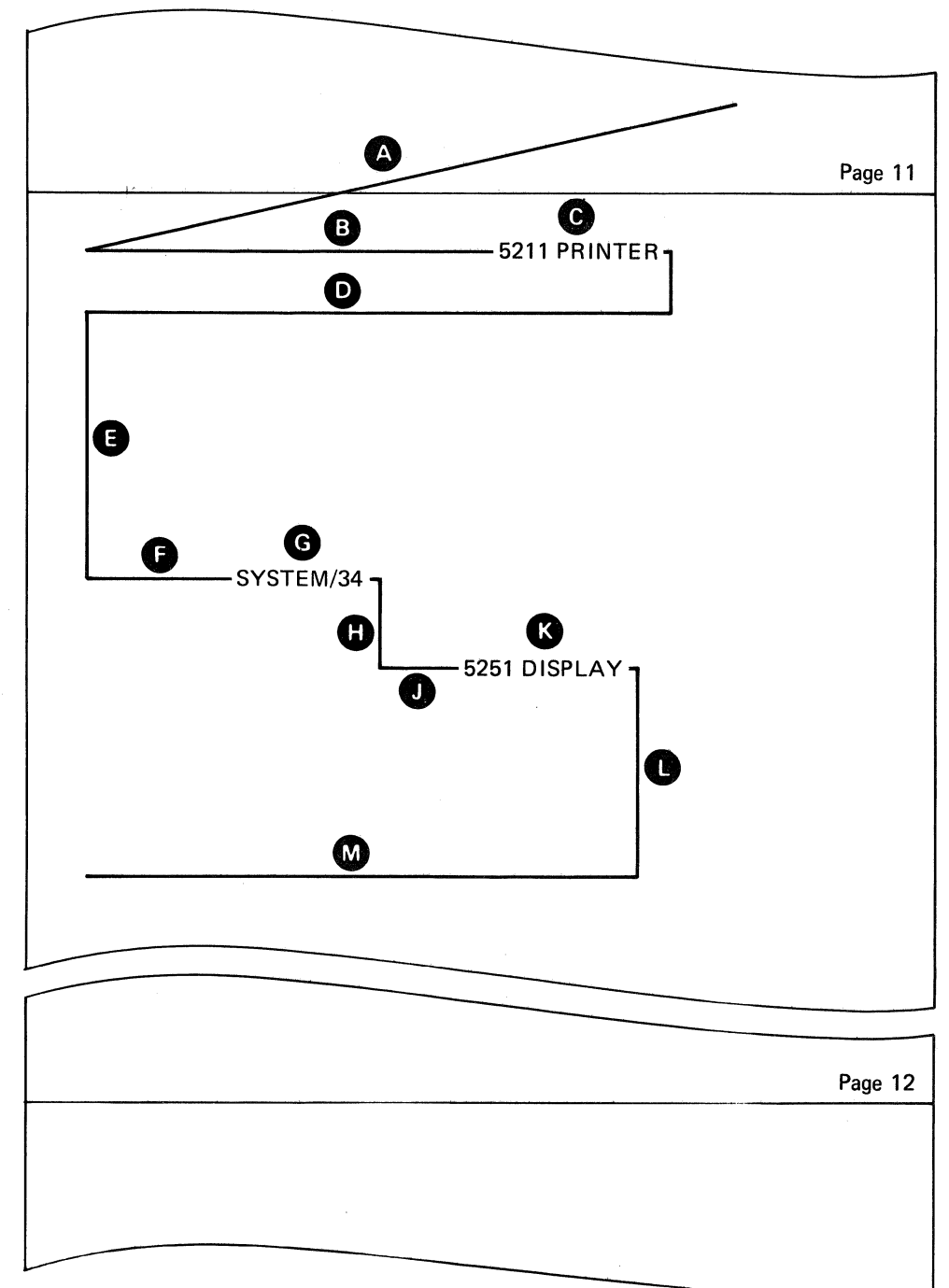

COMMANDS

I/O Load Command

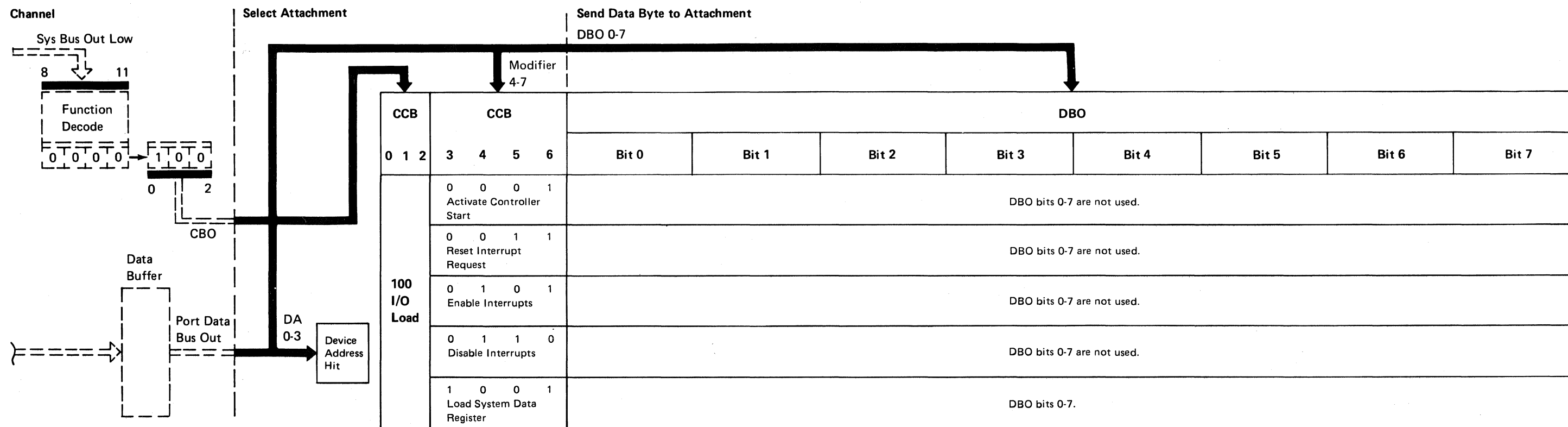

I/O Load Command (continued)

Line Name	FSL Page	CPU Clock															
		0	1	2	3	3	3	3	4	5	6	6	7	7	7	7	0
Port DBO (valid)	PR011	Port Clock															
		C	C	C	C	C	C	C	C	C	C	C	C	C	C	C	C
CBO (valid)	PR011																
Port DBO (valid)	PR011																
Control Out	PR011																
Strobe	PR011																
Data Sample 1	PR011																
Data Sample 2	PR011																
Gate DBI and CBI	PR011																
Multidevice Response	PR011																
Device Selected	PR011																
CCB (valid)	PR011																
Service In	PR011																
Service Out	PR011																
CBI Bit 5 (valid)	PR011																

Modifier Port DBO 4, 5, 6, 7	Port DBO Bit	Command	Action Taken	FSL Page
0 0 0 1		Activate controller start	Activates the 'controller single cycle' line.	PR031
0 0 1 1		Reset interrupt request	Resets the 'interrupt request' latch.	PR021
0 1 0 1		Enable interrupts	Lets interrupt occur when an interrupt condition exists.	PR023
0 1 1 0		Disable interrupts	Does not let interrupt occur when an interrupt condition exists.	PR023
1 0 0 1	0-7	Load system data register	Loads the system data register with the data on port DBO. Also starts the controller clock.	PR021

I/O Control Load Command

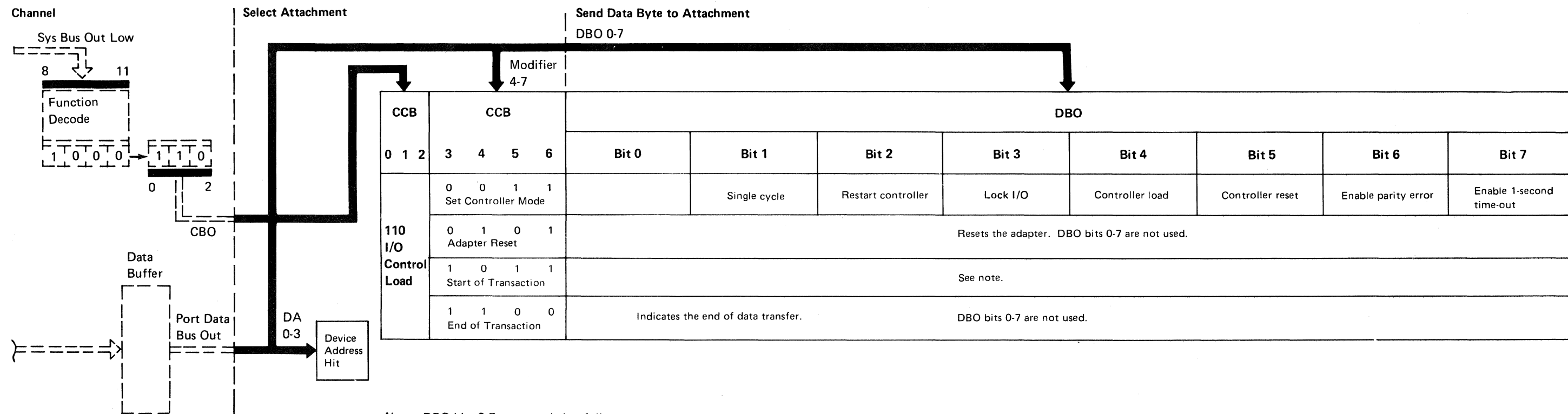

Note: DBO bits 0-7 are encoded as follows:

Hex	Meaning
01	Data transfer
02	Return printer status
04	Dump hammer log tables

I/O Control Load Command
(continued)

Line Name	FSL Page	CPU Clock																T
		0	1	2	3	3	3	3	4	5	6	6	6	6	6	6	6	
CBO (valid)	PR011																	
Port DBO (valid)	PR011																	
Control Out	PR011																	
Strobe	PR011																	
Data Sample 1	PR011																	
Data Sample 2	PR011																	
Gate DBI and CBI	PR011																	
Multidevice Response	PR011																	
Device Selected	PR011																	
CCB (valid)	PR011																	
Service In	PR011																	
Service Out	PR011																	
CBI Bit 5 (valid)	PR011																	

Modifier Port DBO 4, 5, 6, 7	Port DBO Bit	Command	Action Taken	FSL Page
0 0 1 1	1	Single cycle	Sets single-cycle mode. Bit 7 cannot be active.	PR031
	2	Restart controller	Restarts the controller by generating a 400-ns 'controller reset' pulse.	PR031
	3	Lock I/O	Sets lock I/O if active or resets lock I/O if not active.	PR031
	4	Controller load	Sets controller load if active or resets controller load if not active. Bit 7 cannot be active.	PR031
	5	Controller reset	The 'controller reset' line disables controller errors and time-out.	PR031
	6	Enable parity error	Enables the controller errors.	PR031
	7	Enable 1-second time-out	Enables the time-out check.	PR031
0 1 0 1		Adapter reset	Resets all controller modes except controller reset.	PR021
1 0 1 1	0-7	Start of transaction	DBO bits 0-7 are encoded to mean: 01 = Data transfer 02 = Return printer status 04 = Dump hammer log tables	
1 1 0 0		End of transaction	Indicates end of data transfer.	

I/O Sense Command-I/O Control Sense Command

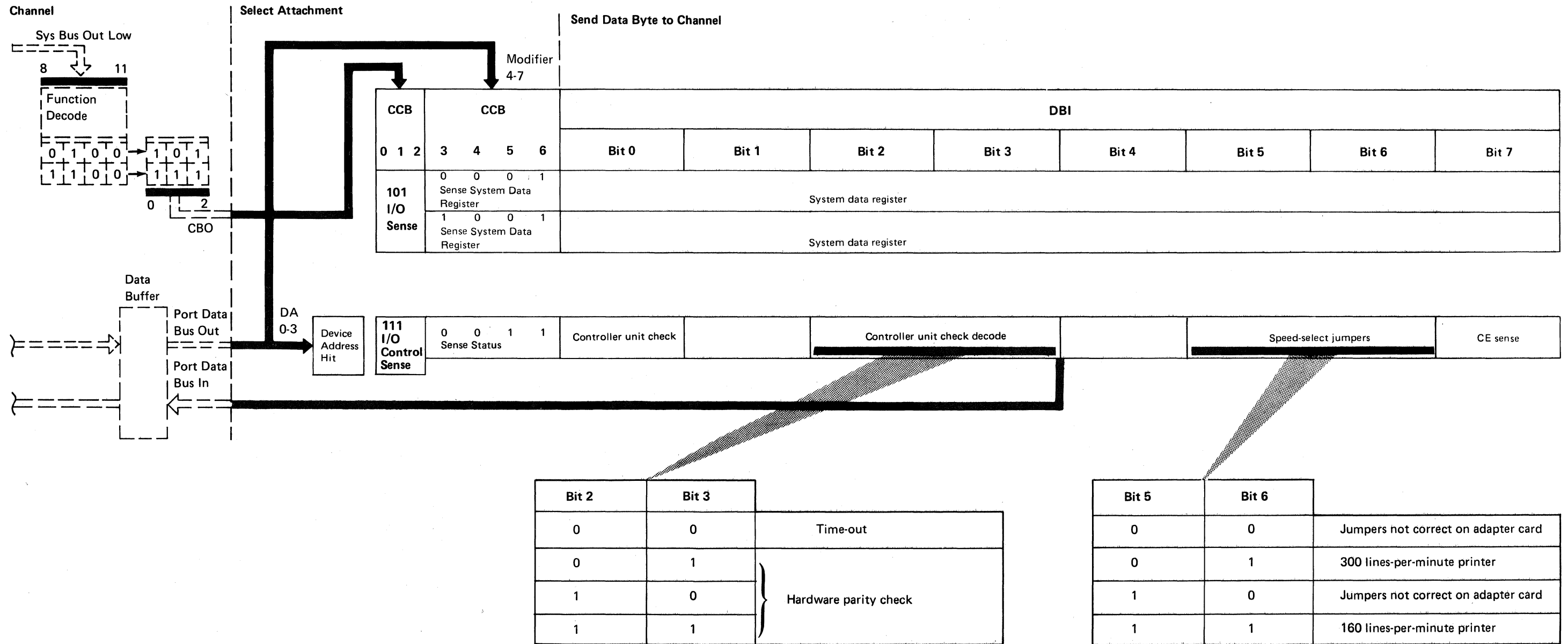

**I/O Sense Command-I/O Control
Sense Command (continued)**

Line Name	FSL Page	CPU Clock															
		T0	T1	T2	T3	T3A	T3B	T3E	T4	T5	T6	T6E	T7	T8	T9	T10	T11
CBO (valid)	PR011																
Port DBO (valid)	PR011																
Control Out	PR011																
Strobe	PR011																
Data Sample 1	PR011																
Data Sample 2	PR011																
Gate DBI and CBI	PR011																
Multidevice Response	PR011																
Device Selected	PR011																
CCB (valid)	PR011																
Service In	PR011																
Service Out	PR011																
Port DBI (valid)	PR023																
CBI Bit 5 (valid)	PR011																

Modifier Port DBO 4, 5, 6, 7	Port DBI Bit	Command	Action Taken	FSL Page
0 0 0 1	0-7	Sense system data register	Gates the contents of the system data register to the channel on DBI. Also resets the 'data ready' line.	PR023
1 0 0 1	0-7	Sense system data register	Same as above but does not reset the 'data ready' line.	PR021
0 0 1 1	0	Sense status	Indicates a controller error.	PR023
	2-3		Identifies the type of controller error (bit 0): 00 = Time-out 01, 10, or 11 = Hardware parity error	PR023
	5-6		Indicates the status of the speed-select jumpers located on the printer adapter card: 00 = Jumpers not correct on adapter card 01 = 300 lines-per-minute printer 10 = Jumpers not correct on adapter card 11 = 160 lines-per-minute printer	PR023
	7		Indicates that the CE sense bit is on.	PR023

Sense Interrupt Level Status Byte Command

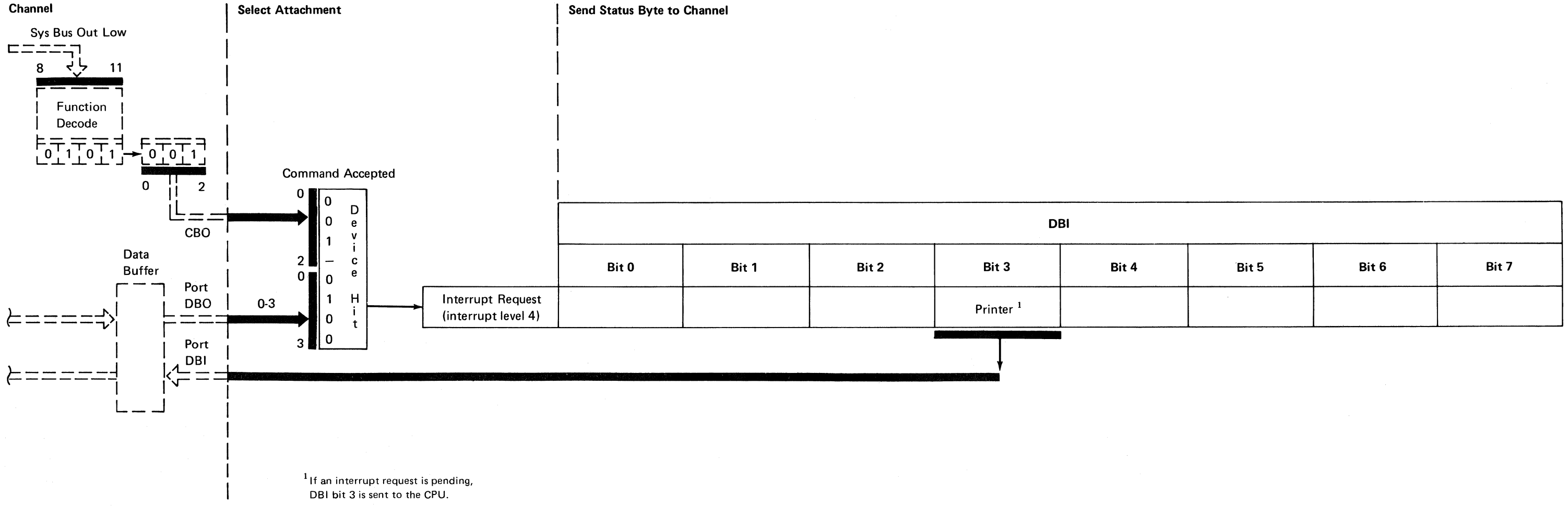

Sense Interrupt Level Status Byte Command (continued)

SILSB-Level 4

		T0	T1	T2	T3	T3	T3	T3	→				T4	T5	T6	T6	→				T0	
						A	B	E								E						
CPU Clock		0	1	2	3	3	3	3					4	5	6	6					0	
Port Clock		C0	C0	C0	C0	C0	C0	C0	C0	C0	C1	C1	C1	C1	C1	C1	C1	C1	C0	C0		
Port Clock		0	0	0	0	9	3	7	F	E	6	2	0	8	9	3	7	F	E	6	2	0
Line Name	FSL Page																					
CBO (valid)	PR011																					
Port DBO (valid)	PR011																					
Control Out	PR011																					
Strobe	PR011																					
Data Sample 1	PR011																					
Data Sample 2	PR011																					
Gate DBI and CBI	PR011																					
Multidevice Response	PR011																					
Device Selected	PR011																					
CCB (valid)	PR011																					
Service In	PR011																					
Service Out	PR011																					
DBI Bit 3 (valid)	PR023																					
CBI Bit 5 (valid)	PR011																					

SILSB-Not Level 4

		T0	T1	T2	T3	T3	T3	T3	→				T4	T5	T6	T6	→				T0	
						A	B	E								E						
CPU Clock		0	1	2	3	3	3	3					4	5	6	6					0	
Port Clock		C0	C0	C0	C0	C0	C0	C0	C0	C0	C1	C1	C1	C1	C1	C1	C1	C1	C0	C0		
Port Clock		0	0	0	0	9	3	7	F	E	6	2	0	8	9	3	7	F	E	6	2	0
Line Name	FSL Page																					
CBO (valid)	PR011																					
Port DBO (valid)	PR011																					
Control Out	PR011																					
Strobe	PR011																					
Multidevice Response	PR011																					
Service In	PR011																					
Service Out	PR011																					
CBI Bit 5 (valid)	PR011																					

Jump on I/O Command

The printer attachment uses CBI bit 4 to indicate if the I/O condition is met. See the second-level diagram on the next page to see how CBI bit 4 is generated.

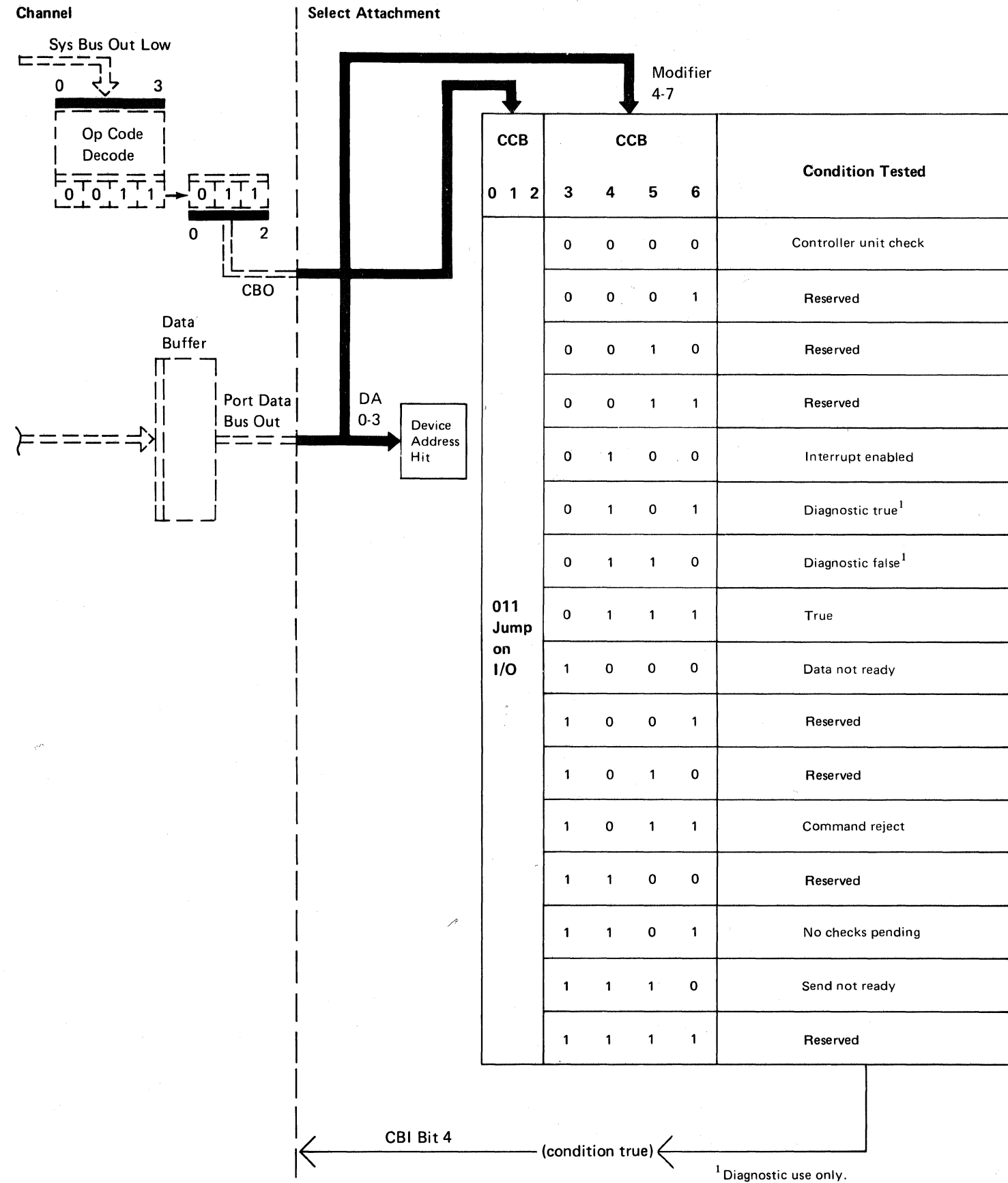

Jump on I/O Command
(continued)

Line Name	FSL Page	CPU Clock															
		T0	T1	T2	T3	T3A	T3B	T3E	T4	T5	T6	T6E	T0				
CBO (valid)	PR011																
Port DBO (valid)	PR011																
Control Out	PR011																
Strobe	PR011																
Data Sample 1	PR011																
Data Sample 2	PR011																
Gate DBI and CBI	PR011																
Multidevice Response	PR011																
Device Selected	PR011																
CCB (valid)	PR011																
Service In	PR011																
Service Out	PR011																
CBI Bit 4 (valid)	PR011																
CBI Bit 5 (valid)	PR011																

Modifier Port DBO 4, 5, 6, 7	Command	Action Taken (see note)	FSL Page
0 0 0 0	Controller unit check	Branches if a controller error condition exists.	PR025
0 1 0 0	Interrupt enabled	Branches if interrupts are enabled.	PR025
0 1 0 1	Diagnostic true	Causes an unconditional branch.	PR025
0 1 1 0	Diagnostic false	Should never cause a branch condition.	PR025
0 1 1 1	True	Causes an unconditional branch.	PR025
1 0 0 0	Data not ready	Branches if the 'data ready' line is not active.	PR025
1 0 1 1	Command reject	Branches if previous load command was rejected and there is no controller error; the command must be retried.	PR025
1 1 0 1	No checks pending	Branches if no checks are pending and there is no controller error.	PR025
1 1 1 0	Send not ready	Branches if the 'send ready' line is not active and there is no controller error.	PR025

Note: All branch conditions are caused by CBI bit 4 going active.

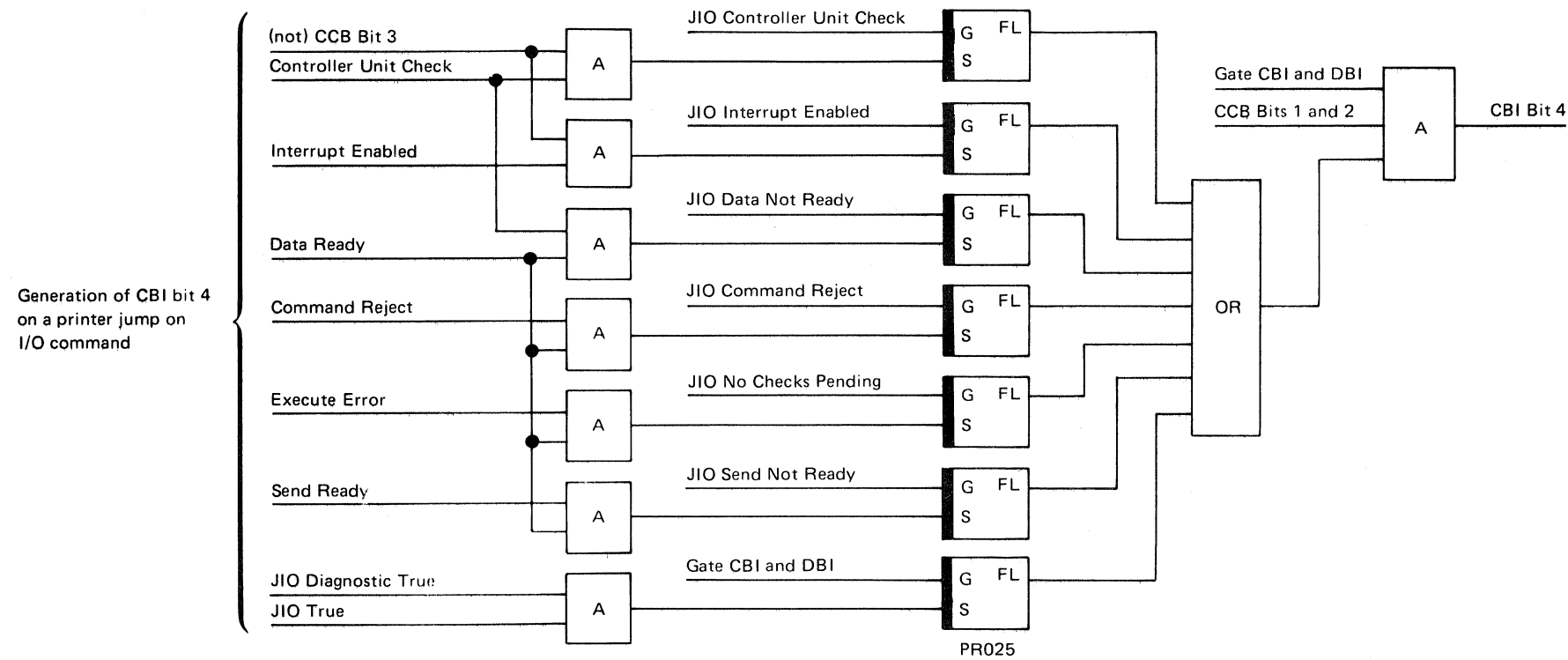

ERROR CONDITIONS

When an error is sensed, the error is posted by setting a bit in the terminal unit block (using bytes 10 through 15 of the terminal unit block, which are equal to status bytes 0 through 5, respectively). In the following descriptions, the status byte and bit are given in parentheses after the error condition name.

The table on the facing page gives:

- The error condition by byte, and by bit
- The name of the error
- Whether or not the error is logged in ERAP
- The alphabetic character (from the *Data Flow* diagram) of the functional unit that senses the error condition or indicates how the logic is generated in the 5340 System Unit
- The FSL page reference
- The error type; that is, whether the error is hard or soft
- The recovery action needed, and a description of the recovery action

Section 85 of the *5340 System Unit Maintenance Manual* shows the error counter table and the error history table for the line printer. It also indicates the error log map to go to, for the check indicated.

Printer Controller Unit Check (Byte 0, Bit 0): Indicates that a hardware parity error or a time-out error occurred. When this bit is set, the remaining bits of status byte 0 have meaning—as described under *System Status Gate*, under *Functional Units*, earlier in this section. In addition, the system zeros out the remaining 5 status bytes.

Unprintable Character (Byte 0, Bit 1): Indicates that a print character not specified in the belt image was sensed.

Hammer Echo Check (Byte 0, Bit 2): Indicates that an optioned hammer did not fire or that a hammer that was not optioned is on.

Not Ready (Byte 0, Bit 3): Indicates that the printer is not ready to print.

Belt Sync Check (Byte 0, Bit 4): Indicates that a 'home' pulse failed to occur or that it occurred when not expected. This check may be caused if the system is not configured for the type belt that is installed in the 5211 Printer.

Belt Speed Check (Byte 0, Bit 5): Indicates that the 'belt up to speed' signal from the printer went not active when not expected.

Belt Up To Speed Check (Byte 0, Bit 6): Indicates that the belt failed to get up to speed in 2.8 seconds after the rise of the 'belt go' line.

Any Hammer On Check (Byte 0, Bit 7): Indicates that a hammer is on during not print time.

End of Forms (Byte 1, Bit 0): Indicates that less than 13 inches of forms remain in the printer below the current print line.

Forms Jam Check (Byte 1, Bit 1): Indicates that the paper has not moved in the last 10 to 22 print lines.

Throat Open (Byte 1, Bit 2): Indicates that the throat is open or the belt cover is not in place.

Printer Busy Too Often Check (Byte 1, Bit 3): Indicates that the 'print busy' line was active more than three times during a single print operation.

Printer Busy Too Long Check (Byte 1, Bit 4): Indicates that the 'print busy' line was active longer than 3 seconds.

Ribbon Check (Byte 1, Bit 5): Indicates that the ribbon play out reel is moving too slowly.

Cable Interlock Check (Byte 1, Bit 6): Indicates that the printer cable interface has a disconnected cable in either the attachment board, the cable tower, or the printer unit.

Data Parity Check (Byte 1, Bit 7): Indicates that even print data parity was sensed during print time. This error can occur if hammers are optioned when the paper clamp is open.

Not Powered On (Byte 2, Bit 0): Indicates that the printer is not powered on.

Data Transfer Check (Byte 2, Bit 1): Indicates that either a byte of data was lost or an extra byte was sensed while sending data from the system to the printer controller.

Data Stream Reject (Byte 2, Bit 2): Indicates that an invalid data stream was sent to the printer.

Invalid SCS Parameter (Byte 2, Bit 4): Indicates that at least one of the parameter bytes following an SNA character string (SCS) control character was not recognized by the controller.

Invalid SCS Command (Byte 2, Bit 5): Indicates that an invalid control character was sensed in the data stream.

Invalid IOB (Byte 2, Bit 6): Indicates that the data stream length in the IOB is more than 256 bytes or that an invalid command code or command modifier was sensed.

Printer Power Check (Byte 2, Bit 7): Indicates that the printer has lost power when not expected.

CE Switch On (Byte 3, Bit 0): Indicates that any CE switch on the 5211 Printer is on.

Fire Tier Check (Byte 3, Bit 4): Indicates that the fire tier lines are out of sequence.

Print Subscan Emitter Check (Byte 3, Bit 5): Indicates that the print subscan time is more than 880 microseconds.

Carriage Check 2 (Byte 3, Bit 6): A single-space operation did not complete in 34 milliseconds, the time needed to keep printing at the rated speed. This error is also called carriage speed check.

Carriage Check 1 (Byte 3, Bit 7): A carriage emitter pulse did not occur when expected or occurred when not expected. This error is also called carriage sync check.

First Failing Hammer (Byte 4, Bits 0 through 7): Indicates the number of the first failing hammer when the hammer echo check bit (bit 2 of status byte 0) is on.

Number of Failing Hammers (Byte 5, Bits 0 through 7): Indicates the number of failing hammers when the hammer echo check bit (bit 2 of status byte 0) is on.

ERROR CONDITIONS (continued)

Byte	Bit	Name of Error	Logged in ERAP	Functional Unit (see note)	FSL Page Reference	Error Type		Recovery Action Needed
						Hard	Soft	
0	0	Printer Controller Unit Check	Yes	N	PR045	X		5
	1	Unprintable Character	No				X	1
	2	Hammer Echo Check	Yes	U	PR161		X	1
	3	Not Ready	No	V	PR820		X	4
	4	Belt Sync Check	Yes		PR820		X	1
	5	Belt Speed Check	Yes		PR820		X	1
	6	Belt Up To Speed Check	Yes		PR820		X	1 or 6
	7	Any Hammer On Check	Yes	S U	PR103	X		1
1	0	End of Forms	No	S	PR810	X		3
	1	Forms Jam Check	Yes		PR101		X	2
	2	Throat Open	No	S	PR003	X		1 or 4
	3	Printer Busy Too Often Check	Yes	U	PR820		X	1
	4	Printer Busy Too Long Check	Yes	U	PR820		X	1
	5	Ribbon Check	Yes	S	PR810	X		1
	6	Cable Interlock Check	Yes	S	PR810	X		1
	7	Data Parity Check	Yes	S	PR810	X		1
2	0	Not Powered On	No	U	PR003	X		4
	1	Data Transfer Check	Yes				X	5
	2	Data Stream Reject	No				X	5
	4	Invalid SCS Parameter	No				X	5
	5	Invalid SCS Command	No				X	5
	6	Invalid IOB	No				X	5
		7	Printer Power Check	Yes	U	PR820	X	
3	0	CE Switch On	No	S	PR102	X		4
	4	Fire Tier Check	Yes	T H	PR111		X	1
	5	Print Subscan Emitter Check	Yes		PR102		X	1
	6	Carriage Check 2	Yes	R	PR103		X	2
	7	Carriage Check 1	Yes	R	PR103		X	2

Note: The alphabetic characters in the *Functional Unit* column are references to the functional units on the data flow figure earlier in this section.

Description of Recovery Actions	
1	<ol style="list-style-type: none"> 1. Correct the error condition. 2. Press the Stop/Reset key to reset the error condition. 3. Press the Ready key.
2	<ol style="list-style-type: none"> 1. Press the Stop/Reset key to reset the error condition. 2. Press the Carriage Restore key. 3. Align the forms to line 1. 4. Press the Ready key.
3	<ol style="list-style-type: none"> 1. Press the Stop/Reset key to reset the error condition. 2. Put more forms in the printer. 3. Press the Ready key.
4	<ol style="list-style-type: none"> 1. If the Interlock light is on, correct the condition that caused the interlock and then press the Ready key. 2. If the Interlock light is off, press the Ready key.
5	Cancel the job from the system console.
6	An error was sensed but the printer recovered automatically.

INPUT/OUTPUT LINES

The input/output lines between the printer attachment and the 5211 Printer are separated into three groups: hammer interface lines, control interface lines, and operator panel interface lines. Note that each line is marked with an arrow to show where the signal is generated. For example, if the signal is generated in the printer attachment, the arrow points toward the printer.

For a complete description of how the input/output lines are used in the printer, see the *5211 Printer Maintenance Information* manual.

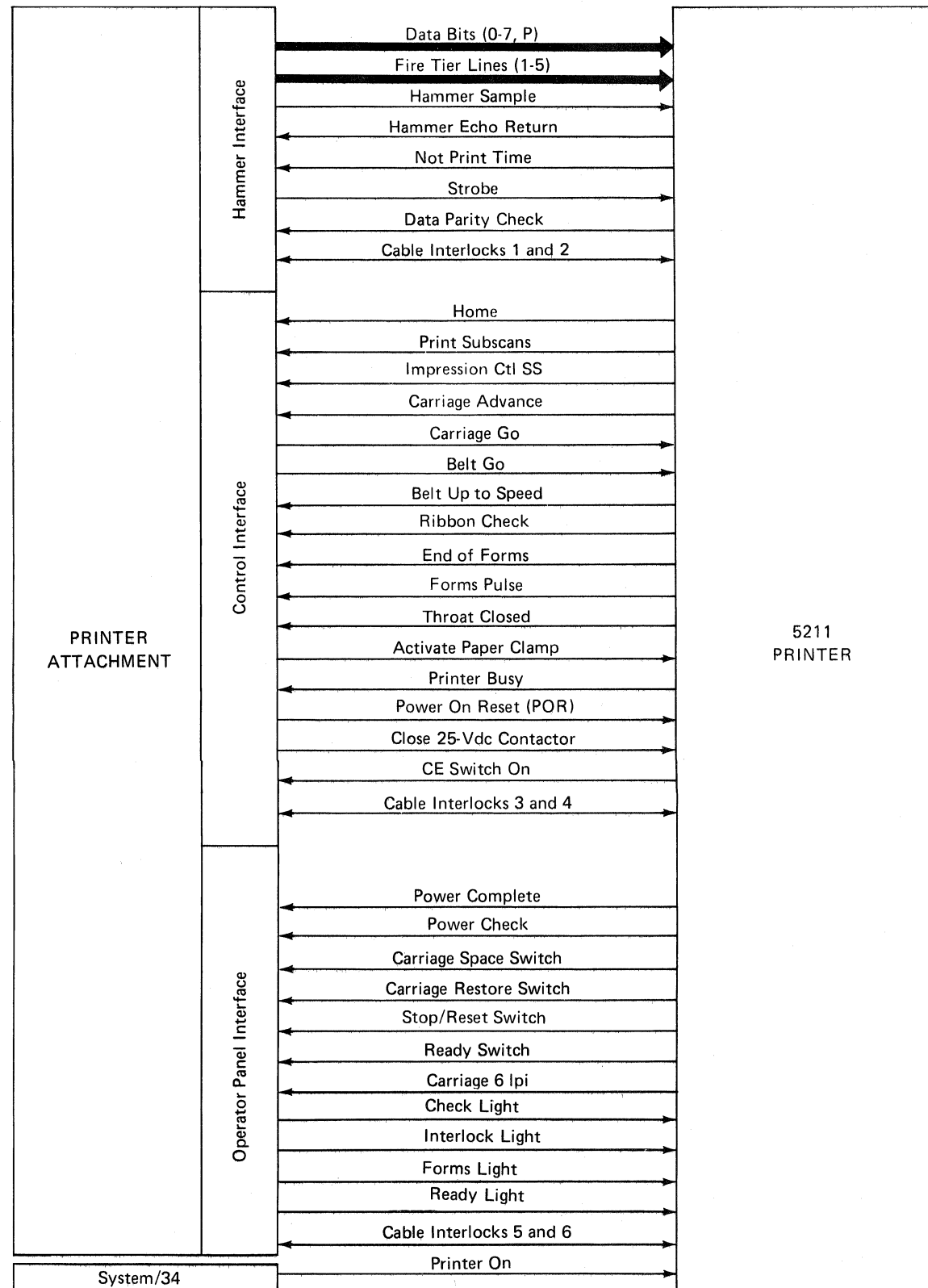

Hammer Interface Lines

Data Bits (0-7, P)

The data bit lines, transmitted from the printer attachment to the 5211 Printer, determine which hammers are to be fired in each subscan. The following figure shows the relationship between these bits and the hammers that are fired.

Hammer Position	Data Bits								Hex Number (see note)
	0	1	2	3	4	5	6	7	
1	0	0	0	0	0	0	0	0	00
2	0	0	0	0	0	0	0	1	01
66	0	1	0	0	0	0	0	1	41
67	0	1	0	0	0	0	1	0	42
132	1	0	0	0	0	0	1	1	83

Note: The hexadecimal number (when converted to decimal) is always one number less than the print position. For example, print position 66 has a hexadecimal value of 41, which is 65 in decimal. However, for a hammer echo check, the hexadecimal number, representing the first failing hammer (status byte 4), is also equal to the print position. For example, if print position 66 was the first failing, status byte 4 would contain hex 42.

Fire Tier Lines (1-5)

The fire tier lines are generated by the adapter using the 'home', 'print subscans', and 'impression ctl SS' lines from the printer and the 'even scans' line (for the Model 1 printer) from the adapter. The fire tier lines are then sent to the printer to fire the hammers. To better understand the timing relationship of the fire tier lines to the 'home', 'print subscans', and 'impression ctl SS' lines, see the timing chart under *Print Subscans* later in this section.

For a second-level diagram of the fire tier lines, see *Fire Tier Circuits* under *Functional Units* earlier in this section.

Hammer Sample and Hammer Echo Return

With these two lines and with the hammer echo check circuits in the 5211 Printer, the printer attachment can determine the parity of the number of hammers that are on during each subscan.

To determine if any hammers are on during print time, the printer attachment transmits 134 pulses to the printer on the 'hammer sample' line. Then, after serially decoding these pulses, the printer returns the status of each hammer on the 'hammer echo return' line.

The first of the 134 pulses is a synchronization pulse used to synchronize the printer. The next 132 pulses are used to sample the 132 print positions (hammers). The second pulse samples print position 1, the third pulse samples print position 2, and so on until the 133rd pulse samples print position 132. The last pulse is not used.

The parity of the number of pulses returned to the printer attachment is generated and, if the parity is not equal to the parity expected, the controller again samples the hammers (under microcode control) to determine the first failing hammer (status byte 4) and the number of hammers that failed (status byte 5). Then, the 25-Vdc contactor is opened and power to the printer is de-activated.

The following figure shows that if hammers 2, 67, and 132 are on, three pulses are returned to System/34 on the 'hammer echo return' line. For more information, see *Hammer Echo Check and Counter* under *Functional Units* earlier in this section.

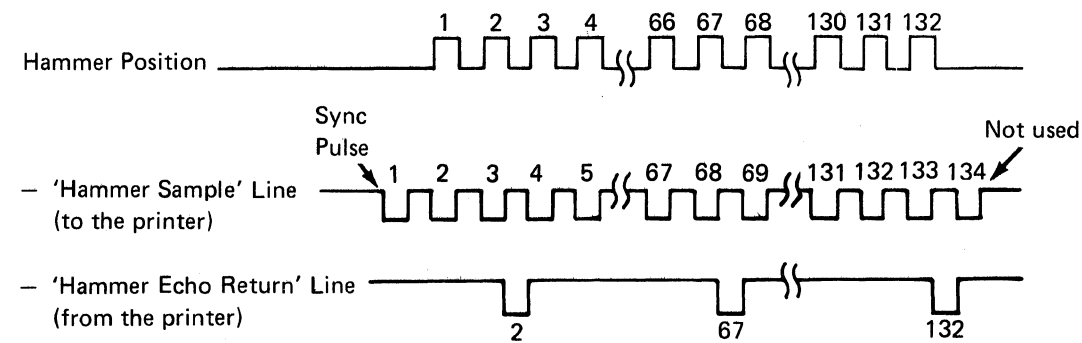

Note: Hammer 2 is the first failing hammer, and there are 3 failing hammers (2, 67, and 132).

Not Print Time

When the 'not print time' line from the printer is active, there is no printing. To ensure that no hammers are on while the 'not print time' line is active, the 'hammer echo return' line is checked to sense any hammer that might be on. If a hammer is on, the 25-Vdc contactor in the printer is opened and power to the printer is de-activated.

Strobe and Data Parity Check

The printer supplies odd parity checking for the data bits (0-7). If an even parity condition is sensed, a latch in the printer is set by the 'strobe' line from the printer attachment. In turn, the 'data parity check' line is sent to the printer attachment and a 'power on reset' line is generated, which opens the 25-Vdc contactor in the printer.

Cable Interlocks (1-6)

As the following figure shows, there are two cable interlock lines on each cable connector between the printer attachment and the 5211 Printer. There are also two cable interlock lines inside the 5211 Printer. If any of the cable connectors or cables to the printer console are not seated correctly, the circuit is opened and the error condition is sensed in the printer attachment.

Note that line 1 is tied to ground, line 2 is connected to line 3, line 4 is connected to line 5, and line 6 is connected (through a resistor) to +5 Vdc. Line 6 is sensed for 0 volts; if line 6 is not at 0 volts, one or more of the cable connectors are not seated correctly.

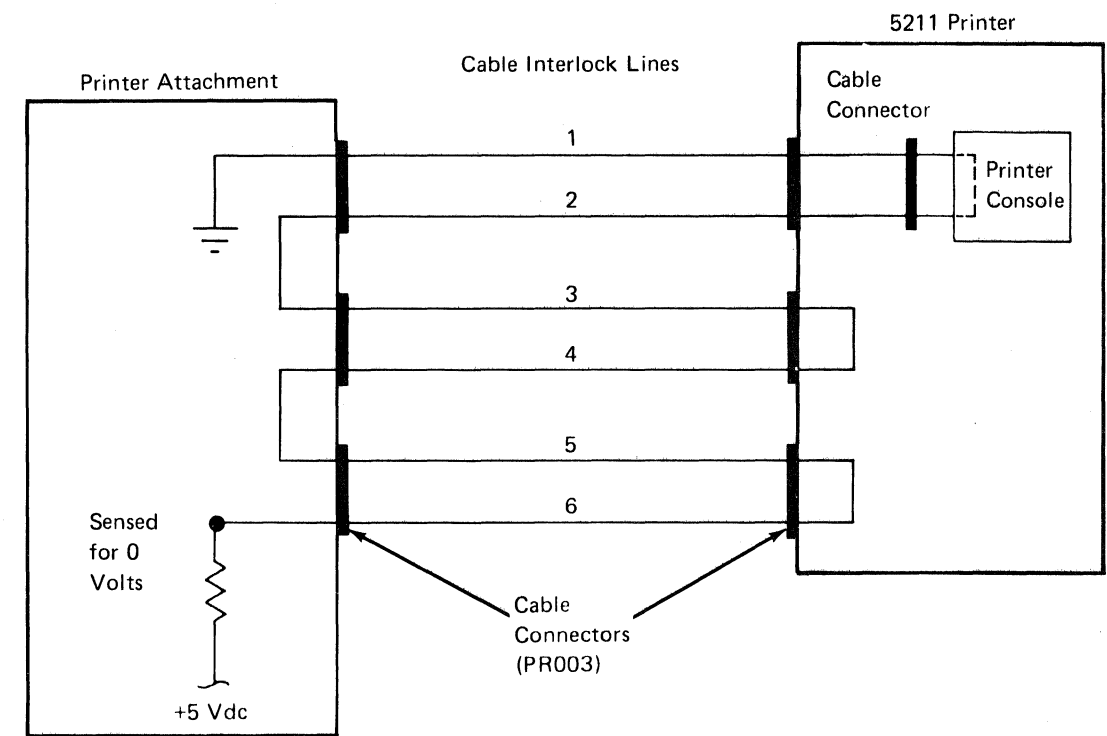

Control Interface Lines

Home

The home pulses are generated in the printer by the missing timing marks on the print belt. Because there are four missing timing marks on the 48-character print belt, four home marks are generated for each revolution of the print belt. The 'home' pulse is generated one and one-half subscans in advance of the time that the first character of an array (four arrays on the 48-character print belt) is optioned to print in print position 1.

This pulse is used to maintain belt synchronization; it is not valid until the 'belt up to speed' line is active.

Impression Control SS

The 'impression ctl SS' line controls the time that the hammers are fired for different forms thickness. It is activated when the 'print subscans' pulse goes not active (halfway into a subscan) and remains active for 251 to 523 microseconds, depending on the setting of the forms thickness control on the printer. To better understand the timing relationship of the 'impression ctl SS' line to the 'home', 'print subscans', and fire tier lines, see the timing chart under *Print Subscans*.

Print Subscans

The print subscans are the basic print timing pulses. They are used to control print optioning and to generate the fire tier lines. The following timing chart shows the relationship of the three signals from the printer to the fire tier lines that are returned to the printer.

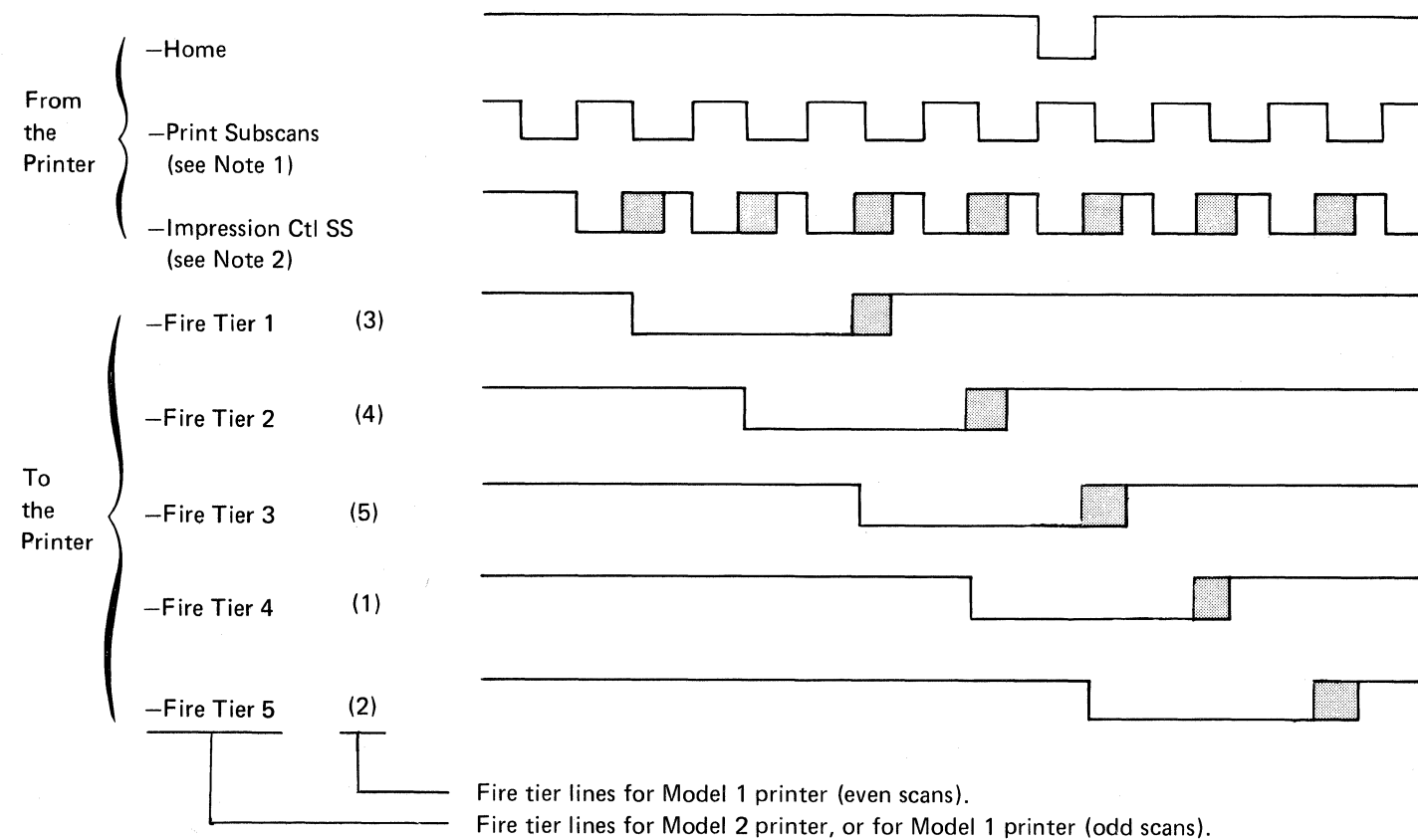

Notes:

1. The 'print subscans' line is not valid until the 'home' pulse is active, and the 'home' pulse is not valid until the 'belt up to speed' line is active.
2. The 'impression ctl SS' line (going not active) de-activates the fire tier lines. The longer the 'impression ctl SS' line stays active, the longer the fire tier lines stay active and, therefore, the longer the hammers are fired.

Carriage Go and Carriage Advance

The 'carriage go' line from the printer attachment activates the print carriage motor, and the 'carriage advance' pulses are generated as a result of forms tractor motion. Then, the 'carriage advance' pulses are sent to the attachment to control the active time of the 'carriage go' line. The 'carriage go' line is reset three 'carriage advance' pulses before the end of carriage motion. The following timing chart shows the relationship of these two lines when a printer is operating at 6 lines per inch. If the printer is operating at 8 lines per inch, only three 'carriage advance' pulses would occur when the 'carriage go' line is active.

Note: To advance the carriage n number of lines, a total of 8n 'carriage advance' pulses are needed for a printer operating at 6 lines per inch; 6n pulses for a printer operating at 8 lines per inch. For example, to advance the carriage 10 lines on a printer operating at 6 lines per inch, 80 (8 x 10) 'carriage advance' pulses are needed.

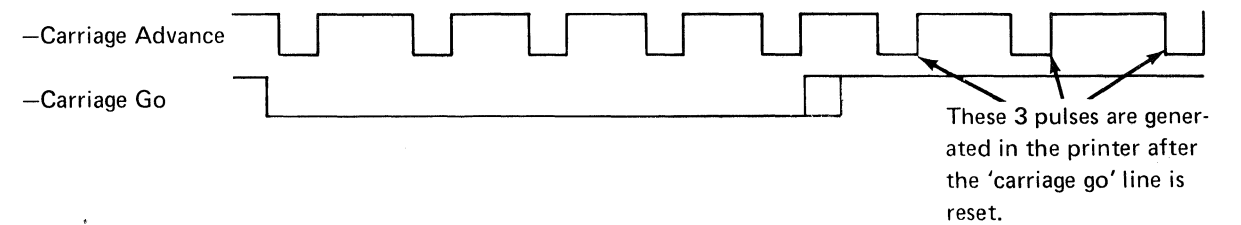

Belt Go and Belt Up to Speed

The 'belt go' line from the printer attachment to the printer starts the print belt. When the belt is running at nominal speed (approximately 1.4 seconds after the 'belt go' line is activated), the 'belt up to speed' line goes active. In addition, the 'home' pulse and the 'print subscans' pulse are not valid until the belt is up to speed.

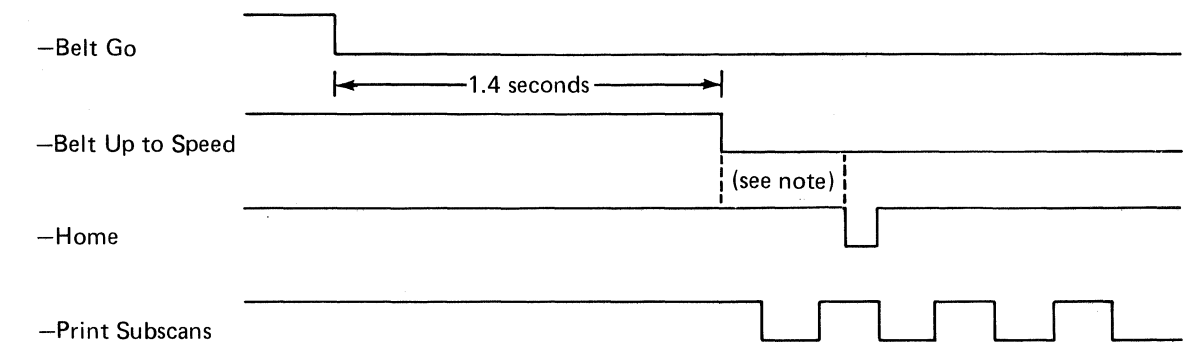

Note: The 'home' pulse may not always occur where shown in this timing chart. The time between an active 'belt up to speed' line and an active 'home' pulse may vary.

The 'belt go' line is de-activated if no print command is received in approximately two minutes after the belt is running at nominal speed; this ensures minimum wear to the print belt and ribbon because the belt stops running when the 'belt go' line is not active. Similarly, the 'belt up to speed' line is de-activated inside of 1 microsecond after the 'belt go' line is de-activated. Also, when the 'belt up to speed' line is de-activated, the print subscans are de-activated.

Ribbon Check

This line goes active if the ribbon is not moving at the correct speed while printing. In response to the 'ribbon check' line, the printer attachment activates a check condition that stops the printer.

End of Forms

This line goes active when only 13 inches of forms remain in the printer. In response to the 'end of forms' line, the printer attachment causes the printer to stop and the Forms light to go on.

Forms Pulse

This line goes active when tractor holes are sensed at the left margin of the forms; it is used to determine a forms-jammed condition. A forms-jammed condition occurs if 10 to 20 lines of paper are moved in the printer before the 'forms pulse' signal is sensed.

Throat Closed

If the throat interlock switch in the printer is not closed, and if the belt cover is not in place, the printer is not ready and System/34 cannot use the printer. The throat must be closed and the belt cover must be in place before any printing can occur.

Activate Paper Clamp

This line from the printer attachment lets the system control the paper clamp in the printer. The line is active during print time but is not active during carriage operations or during idle times to permit manual paper advance.

Printer Busy

This line goes active when the ribbon drive is reversed on the printer, or when the belt starts to lose speed because of heavy loading (many hammers are fired). Print optioning is inhibited until this line goes not active.

Power On Reset

The printer uses this line during the power-on sequence to reset the printer circuits to their starting conditions. During the power-on sequence, the 'power on reset' line remains active for a maximum of 300 milliseconds after the 25-Vdc contactor makes. Also, the printer attachment activates a power on reset after sensing an error condition from the printer—error conditions that include hammer echo check, carriage sync check, and data parity check.

Close 25-Vdc Contactor

This line is activated after the 'power complete' line is at 0 volts; it is activated to switch the +25 Vdc in the printer. The line is forced not active when a data parity check, or any hammer on check, or carriage sync check is sensed to protect the hammer coils.

CE Switch On

This line indicates one of the CE switches on the 5211 Printer is on.

Operator Panel Interface Lines

Power Complete and Power Check

The printer attachment checks these two lines to determine the status of power in the printer. The 'power complete' line is active after the power-on sequence is complete. The 'power check' line is active if exceptional conditions in the printer cause the power to drop.

Carriage Space Switch and Carriage Restore Switch

The printer attachment responds to either of these lines by activating the 'carriage go' line, which controls the print carriage motor.

The Carriage Space and Carriage Restore switches on the printer are operational only when the printer is not ready. Therefore, to use either of these switches, first press the Stop/Reset switch on the printer. The Carriage Space switch moves the paper one line, and the Carriage Restore switch moves the paper to line 1 of the next form.

Ready Switch and Ready Light

The printer attachment responds to the 'ready switch' line by turning on the Ready light if there is no check condition. The attachment also activates the 'belt go' line when the Ready switch is pressed.

Carriage 6 LPI

If this line is active, the printer operates at 6 lines per inch; if this line is not active, the printer operates at 8 lines per inch. This line is activated by a switch in the printer.

Check, Interlock, and Forms Lights

The printer attachment uses these three lines to turn on the respective lights on the printer. The Interlock light is turned on when the 'throat closed' line is not active, and the Forms light is turned on when the 'end of forms' line is active. The Forms and Check lights both turn on when a forms-jammed or carriage-check condition is sensed.

The Check light is turned on when the accuracy of printing is in question for any of the following reasons (error conditions):

- Carriage sync check (the Forms light is also on)
- Carriage speed check (the Forms light is also on)
- Forms jammed (the Forms light is also on)
- Hammer echo check
- Any hammer on check
- Belt sync check
- Belt speed check
- Belt up to speed check
- Data parity check
- Fire tier check
- Ribbon check
- Printer busy too often check
- Printer busy too long check
- Print subscan emitter check
- Unprintable character check

This page intentionally left blank.

