



**NOS 2
APPLICATION INSTALLATION
HANDBOOK**

**CDC® COMPUTER SYSTEMS:
CYBER 170
CYBER 70
MODELS 71, 72, 73, 74
6000 SERIES**

LIST OF EFFECTIVE PAGES

New features, as well as changes, deletions, and additions to information in this manual, are indicated by bars in the margins or by a dot near the page number if the entire page is affected. A bar by the page number indicates pagination rather than content has changed.

PAGE	REV	PAGE	REV	PAGE	REV	PAGE	REV	PAGE	REV
Front Cover	-	UNIPL0T-5	A						
Title Page	-	UNIPL0T-6	A						
2	C	UNIPL0T-7	A						
3/4	C	UNIPL0T-8	A						
5	C	UNIPL0T-9	A						
6	C	UNIPL0T-10	A						
7	C	UNIPL0T-11	A						
8	C	UNIPL0T-12	A						
9	C	UNIPL0T-13	A						
10	B	UNIPL0T-14	A						
APEX-1	A	UNIPL0T-15	A						
APT-1	A	UNISTRUC II-1	C						
APT-2	A	UNISTRUC II-2	C						
CDCSV-1	C	UNISTRUC II-3	C						
CDCSV-2	C	UNISTRUC II-4	C						
CDCSV-3	C	UNISTRUC II-5	A						
CD/2000-1	C	UNISTRUC II-6	C						
CD/2000-2	C	UNISTRUC II-7	C						
CD/2000-3	C	UNISTRUC II-8	C						
CD/2000-4	C	UNISTRUC II-9	C						
CD/2000-5	C	UNISTRUC II-10	A						
CD/2000-6	C	UNISTRUC II-11	C						
EDL-1	C	UNISTRUC II-12	C						
EDL-2	C	UNISTRUC II-13	C						
EDL-3	C	UNISTRUC II-14	C						
GPSS-1	A	UNISTRUC II-15	C						
GTICES/ STRU DL-1	A	Comment Sheet	C						
GTICES/ STRU DL-2	A	Back Cover	-						
GTICES/ STRU DL-3	A								
IMSL-1	C								
IPF2-1	C								
IPF2-2	C								
PDS-1	A								
PERT/TIME-1	A								
SIMSCRIPT-1	C								
TIGS-1	B								
TIGS-2	C								
TIGS-3	B								
TIGS-4	C								
TIGS-5	B								
TIGS-6	B								
TIGS-7	C								
TIGS-8	B								
TIGS-9	B								
TIGS-10	B								
TIGS-11	B								
TIGS-12	C								
TIGS-13	C								
TIGS-14	B								
TOTAL-1	C								
TOTAL-2	A								
TOTAL-3	C								
UNIPL0T-1	A								
UNIPL0T-2	A								
UNIPL0T-3	C								
UNIPL0T-4	A								

PREFACE

The following sections are arranged alphabetically by product name (see contents) for ease in usage. The sections present information pertaining to the installation of applications software under the CONTROL DATA® Network Operating System (NOS) Version 2, and where applicable, the CDC® Network Access Method and CDC Interactive Facility (NAM and IAF). While the information in this handbook describes the application installation, users should reference the NOS 2 Reference Set, Volume 1, and the NOS 2 Installation Handbook for additional information regarding the use of NOS 2.

AUDIENCE

Control Data assumes that the installation of applications software is performed by an analyst with experience with a CDC CYBER 170 Computer System; CDC CYBER 70 Computer System, Model 71, 72, 73, or 74; or CDC 6000 Computer System.

RELATED PUBLICATIONS

The following manuals contain relevant information for the operating system or application products described in this manual.

The NOS 2 Manual Abstracts is a pocket-sized manual containing brief descriptions of the contents and intended audience of all NOS 2 and NOS 2 product manuals. The abstracts can be useful in determining which manual is appropriate for your use.

Control Data publishes a Software Publications Release History of all software manuals and revision packets it has issued. This history lists the revision level of a particular manual that corresponds to the level of software installed at the site.

These manuals are available through Control Data Sales offices or Control Data Literature Distribution Services (308 North Dale, St. Paul, Minnesota 55103).

<u>Control Data Publication</u>	<u>Publication Number</u>
APEX-IV Reference Manual	84002550
Automatically Programmed Tooling System (APT IV) Version 2 Reference Manual	17326900
Beginning Graphics User Guide	76077300

<u>Control Data Publication</u>	<u>Publication Number</u>
CDC SynthaVision [†] Reference Manual	60457870
CD/2000 Menu Summary	60457140
CD/2000 Reference Manual	60457130
CD/2000 User's Guide	60456940
Engineering Data Library Data Base Administrator's Manual	60458880
Engineering Data Library Version 1.0 User's Guide	60459740
GPSS V User's Manual	76078800
GPSS V/6000 General Information Manual	84003900
GTICES/STRU DL User Information Manual	84001010
IMSL8.1 Reference Manual Vol.I-III	SMD150050††
IPF2, Information Processing Family Version 2 Application Reference Manual	84001950
NOS Version 2 Installation Handbook	60459320
NOS Version 2 Manual Abstracts	60485500
NOS Version 2 Reference Set, Volume 1, Introduction to Interactive Usage	60459660
PDS/MAGEN User Information Manual	84009900
PERT/Time Reference Manual	60133600
SIMSCRIPT II.5 Programming Language	84000740
SIMSCRIPT II.5 Reference Manual	84000750
SIMSCRIPT II.5 User Information Manual	84000460
Software Publications Release History	60481010

[†]Registered trademark of the Mathematical Applications Group, Inc.
^{††}This manual may be ordered by title from Control Data Corporation, Software Manufacturing and Distribution, 4201 North Lexington Avenue, St. Paul, Minnesota 55112.

<u>Control Data Publication</u>	<u>Publication Number</u>
Terminal-Independent Graphics System Version 1.4 Instant Manual	60456360
Terminal-Independent Graphics System (TIGS) Version 1.4 Reference Manual	60455940
Terminal-Independent Graphics System (TIGS) Version 1.4 User's Guide	60456040
TOTAL Universal Reference Manual	76070300
UNIPLOT Version 3.1 Reference Manual/ User's Guide	60454730

<u>Control Data Publication</u>	<u>Publication Number</u>
UNISTRUC II Reference Manual	76079600
UNISTRUC II User's Guide	60457550

DISCLAIMER

NOS and its product set are intended for use only as described in this document. Control Data cannot be responsible for the proper functioning of undescribed features or parameters.

CONTENTS

APEX-IV	APEX-1	Tektronix 4114 Terminals Notes and Cautions	CD/2000-3 CD/2000-3
APEX-IV V1.0	APEX-1	CD/2000 Utility Package	CD/2000-3
Release Description	APEX-1	Release Materials	CD/2000-3
Hardware Requirements	APEX-1	UNIPLLOT Utility Installation and	
Release Materials	APEX-1	Verification Procedures	CD/2000-4
Installation and Verification		Installation Procedure	CD/2000-4
Procedure	APEX-1	Verification Procedure	CD/2000-4
		Notes and Cautions	CD/2000-5
		IGES-CD/2000 Translators Installation	
		and Verification Procedures	CD/2000-5
APT IV 2	APT-1		
APT IV V2	APT-1	ENGINEERING DATA LIBRARY	EDL-1
General Description	APT-1		
Release Materials	APT-1	Release Description	EDL-1
Installation Requirements	APT-1	Hardware Requirements	EDL-1
Installation Procedure	APT-1	Dependencies	EDL-1
Verification	APT-1	Release Materials	EDL-1
Post Processor	APT-2	Installation Procedure	EDL-1
Notes and Cautions	APT-2	Installation Verification	EDL-1
CDC SYNTHAVISION PRODUCTS	CDCSV-1	GPSS V PRODUCTS	GPSS-1
General Description	CDCSV-1	GPSS V V1.3.1	GPSS-1
CDC SynthaVision Interface Package	CDCSV-1	Release Description	GPSS-1
Release Description	CDCSV-1	Hardware Requirements	GPSS-1
Hardware Requirements	CDCSV-1	Release Materials	GPSS-1
Release Materials	CDCSV-1	Installation Procedure	GPSS-1
Installation Requirements	CDCSV-1	Notes and Cautions	GPSS-1
Installation Procedure	CDCSV-1	Permanent Files	GPSS-1
Verification Procedure	CDCSV-1	Execute Only Files	GPSS-1
Notes and Cautions	CDCSV-2		
CDC SynthaVision Image/Analysis Package	CDCSV-2	GTICES/STRU DL PRODUCTS	GTICES/STRU DL-1
Release Description	CDCSV-2	GTICES/STRU DL Overview	GTICES/STRU DL-1
Hardware Requirements	CDCSV-2	Description	GTICES/STRU DL-1
Release Materials	CDCSV-3	GTICES/STRU DL	GTICES/STRU DL-1
Installation Requirements	CDCSV-3	Release Description	GTICES/STRU DL-1
Installation Procedure	CDCSV-3	Hardware Requirements	GTICES/STRU DL-1
Verification Procedure	CDCSV-3	Release Materials	GTICES/STRU DL-1
Notes and Cautions	CDCSV-3	Installation Procedure	GTICES/STRU DL-1
		Notes and Cautions	GTICES/STRU DL-2
CD/2000	CD/2000-1	GTTABLE	GTICES/STRU DL-2
CD/2000 Package V1.4	CD/2000-1	Release Description	GTICES/STRU DL-2
Release Description	CD/2000-1	Hardware Requirements	GTICES/STRU DL-2
Basic Package	CD/2000-1	Release Materials	GTICES/STRU DL-2
Extended Geometry Package	CD/2000-1	Installation Procedure	GTICES/STRU DL-3
Numerical Control (N/C) Package	CD/2000-1	Notes and Cautions	GTICES/STRU DL-3
Hardware Requirements	CD/2000-1		
Release Materials	CD/2000-1	IMSL 9.0	IMSL-1
Installation Procedure	CD/2000-1		
Installation Verification	CD/2000-2	Release Description	IMSL-1
Terminal Setup Procedures	CD/2000-2	Hardware Requirements	IMSL-1
Tektronix 4014/4016 Terminals	CD/2000-2	Notes and Cautions	IMSL-1
Option 1 Initialization	CD/2000-3	Release Materials	IMSL-1
Option 20 Initialization	CD/2000-3	Installation Procedure	IMSL-1

IPF2	IPF2-1	Installation Description	TIGS-7
Release Description	IPF2-1	TIGS Libraries	TIGS-7
Hardware Requirements	IPF2-1	UNIPLLOT Interface	TIGS-7
Release Materials	IPF2-1	Configuration Defaults	TIGS-7
Installation Procedure	IPF2-1	Installation Verification	TIGS-7
Installation Verification	IPF2-2	Neutral Display File Conversion	TIGS-7
		Installation Procedure	TIGS-7
		Terminal Set Up Procedures	TIGS-9
		Verification Procedure	TIGS-9
		Running the NDF Conversion Programs	TIGS-10
PDS/MAGEN PRODUCTS	PDS-1	Tektronix 4114 Postprocessor Option	TIGS-10
		Release Materials	TIGS-10
PDS/MAGEN V1.3B5	PDS-1	Notes and Cautions	TIGS-11
Release Description	PDS-1	Installation Description	TIGS-11
Hardware Requirements	PDS-1	TIGS Libraries	TIGS-11
Deficiencies	PDS-1	UNIPLLOT Interface	TIGS-11
Release Materials	PDS-1	Installation Verification	TIGS-11
Installation Parameters	PDS-1	Neutral Display File Conversion	TIGS-11
Installation Procedure	PDS-1	Installation Procedure	TIGS-11
Installation Verification	PDS-1	Terminal Set Up Procedures	TIGS-12
		Verification Procedure	TIGS-13
		Running the NDF Conversion Programs	TIGS-14
PERT/TIME PRODUCTS	PERT/TIME-1		
PERT/TIME V2.1	PERT/TIME-1	TOTAL PRODUCTS	TOTAL-1
Release Description	PERT/TIME-1	TOTAL Universal 2.1	TOTAL-1
Hardware Requirements	PERT/TIME-1	Release Description	TOTAL-1
Release Materials	PERT/TIME-1	Hardware Requirements	TOTAL-1
Installation Procedure	PERT/TIME-1	Deficiencies	TOTAL-1
Installation Verification	PERT/TIME-1	Release Materials	TOTAL-1
		Installation Procedure	TOTAL-1
		Installation Parameters	TOTAL-2
		Installation Job	TOTAL-2
		Files Created	TOTAL-2
SIMSCRIPT IL5 PRODUCTS	SIMSCRIPT-1	TOTAL Universal Extended 2.1	TOTAL-2
		Release Description	TOTAL-2
SIMSCRIPT IL5 V4.6	SIMSCRIPT-1	Hardware Requirements	TOTAL-2
Release Description	SIMSCRIPT-1	Deficiencies	TOTAL-2
Hardware Requirements	SIMSCRIPT-1	Release Materials	TOTAL-2
Deficiencies	SIMSCRIPT-1	Installation Procedure	TOTAL-2
Release Materials	SIMSCRIPT-1	Installation Parameters	TOTAL-3
Installation and Verification	SIMSCRIPT-1	Installation Job	TOTAL-3
Procedure	SIMSCRIPT-1	Files Created	TOTAL-3
Notes and Cautions	SIMSCRIPT-1		
Permanent Files	SIMSCRIPT-1		
Execute Only Files	SIMSCRIPT-1		
TIGS 1 PRODUCT OPTIONS	TIGS-1	UNIPLLOT V3.1 PRODUCT OPTIONS	UNIPLLOT-1
TIGS 1 Overview	TIGS-1	Release Description	UNIPLLOT-1
Release Description	TIGS-1	Preprocessor-UNIPLLOT Library	UNIPLLOT-1
Hardware Configuration	TIGS-1	Postprocessor - UNIPOST	UNIPLLOT-1
Release Materials	TIGS-1	UNIPOST Standard Device Drivers	UNIPLLOT-1
TIGS 1 Preprocessor	TIGS-1	UNIPOST Optional Device Drivers	UNIPLLOT-1
Tektronix 401X Postprocessor Option	TIGS-1	Hardware Requirements	UNIPLLOT-1
Release Materials	TIGS-1	Graphics Hardware Options	UNIPLLOT-1
Notes and Cautions	TIGS-1	Communications	UNIPLLOT-1
Installation Description	TIGS-2	Release Materials	UNIPLLOT-2
TIGS Libraries	TIGS-2	UNIPLLOT V3.1 System	UNIPLLOT-2
UNIPLLOT Interface	TIGS-2	Tektronix 401X Device Driver	
Configuration Defaults	TIGS-2	(Optional)	UNIPLLOT-2
Installation Verification	TIGS-2	Houston Instruments BTC-7	
Neutral Display File Conversion	TIGS-2	Device Driver (Optional)	UNIPLLOT-2
Installation Procedure	TIGS-2	CalComp 906 Device Driver	
Terminal Set Up Procedures	TIGS-3	(Optional)	UNIPLLOT-3
Tektronix 4006 Terminal	TIGS-3	Installation Procedure	UNIPLLOT-3
Tektronix 4010/4014/4016 Terminals	TIGS-4	Parameter Descriptions	UNIPLLOT-3
Verification Procedure	TIGS-4	Verification Procedures	UNIPLLOT-4
Running the NDF Conversion Programs	TIGS-6	Uniplot Installation Verification	UNIPLLOT-4
Chromatics 1599 Postprocessor Option	TIGS-6	Device Driver Verification	UNIPLLOT-5
Release Materials	TIGS-6	Verification File Purge	UNIPLLOT-5
Notes and Cautions	TIGS-7	UNIPLLOT Access Procedures	UNIPLLOT-5

User Developed Device Driver Interface			
UNIPOST Structure	UNIPILOT-6	UNISTRUC II	UNISTRUC II-1
UNIPOST Device Driver Requests	UNIPILOT-6	Release Description	UNISTRUC II-1
Initialization (IREQ=0)	UNIPILOT-6	Hardware Requirements	UNISTRUC II-1
Vector (IREQ=1)	UNIPILOT-7	Communications	UNISTRUC II-1
Newpen (IREQ=2)	UNIPILOT-7	Tektronix Graphics Terminal	
Text (IREQ=3)	UNIPILOT-7	Setup Procedure	UNISTRUC II-1
Device Mode (IREQ=4)	UNIPILOT-7	Tektronix 4006 Terminal	UNISTRUC II-1
Reorigin Requests (IREQ=5)	UNIPILOT-8	Tektronix 4010/4014/4016 Terminals with Synchronous Interface	UNISTRUC II-2
Increment (IREQ=6)	UNIPILOT-8	Tektronix 4010/4014/4016 Terminals without Synchronous Interface	UNISTRUC II-2
Pen Restore (IREQ=7)	UNIPILOT-8	Tektronix 4113/4114 Terminals	UNISTRUC II-2
Arc (IREQ=8)	UNIPILOT-8	Release Materials	UNISTRUC II-3
Device Control Routine Example	UNIPILOT-8	Installation Procedures	UNISTRUC II-4
User Developed Device Driver Installation	UNIPILOT-9	Verification Procedure	UNISTRUC II-6
Device Hardware Characteristics		UNISTRUC Verification	UNISTRUC II-9
File (DHCFILE)	UNIPILOT-9	Digit Verification	UNISTRUC II-9
Installation Procedure	UNIPILOT-11	Utility Programs Verification	UNISTRUC II-9
Sample Tek Hardware Configuration	UNIPILOT-11	UPLOT Verification Options	UNISTRUC II-11
Configuring the Equipment	UNIPILOT-11	Verification Completion	UNISTRUC II-11
Connecting the Equipment	UNIPILOT-13	UNISTRUC II and Utility	
Sample H1734 Hardware Configuration	UNIPILOT-13	Execution Procedure	UNISTRUC II-11
Connecting the Equipment	UNIPILOT-14	Overview of UNISTRUC II	
Off-line Testing of Plotter	UNIPILOT-14	Programs/Files	UNISTRUC II-12
On-Line Testing	UNIPILOT-14	UNISTRUC II Installation	
Printer Test	UNIPILOT-14	Parameter File - On Site	
Plotter Test	UNIPILOT-14	Maintenance	UNISTRUC II-12
Sample Cal906 Hardware Configuration	UNIPILOT-14	UPDATE Banners	UNISTRUC II-15
Connecting the Equipment	UNIPILOT-15	Known Deficiencies	UNISTRUC II-15
Materials Received with Plotter	UNIPILOT-15		
Off-Line Testing	UNIPILOT-15		

FIGURES

CDCSV-1	Output Received from Running the Verification on a Tektronix 401X Terminal	CDCSV-2	UNIPILOT V3.1-7 Front View and Control Panel	UNIPILOT-15
CDCSV-2	Output Received from Running the Verification on Any Alphanumeric Terminal	CDCSV-2	UNIPILOT V3.1-8 Rear View	UNIPILOT-15
CD/2000-1	Verification Display	CD/2000-2	UNISTRUC II-1 UNISTRUC Verification "EXPLAIN"	UNISTRUC II-7
CD/2000-2	Listing of the INSTAL Procedure File	CD/2000-5	UNISTRUC II-2 UNISTRUC Verification "SETUP" and "RUN"	UNISTRUC II-7
CD/2000-3	Installation/Verification Display	CD/2000-6	UNISTRUC II-3 UNISTRUC Verification Final Screen Picture on a Tektronix 4014 Terminal	UNISTRUC II-8
EDL-1	DBA Tasks Menu	EDL-2	UNISTRUC II-4 UNISTRUC NID Creation "VERIFY"	UNISTRUC II-9
EDL-2	User Profile Management Menu	EDL-2	UNISTRUC II-5 DIGIT Verification "EXPLAIN"	UNISTRUC II-10
EDL-3	Reports Menu	EDL-2	UNISTRUC II-6 DIGIT Verification "SETUP" and "RUN"	UNISTRUC II-10
EDL-4	Sample User Profile Report	EDL-3	UNISTRUC II-7 DIGIT Verification "VERIFY"	UNISTRUC II-10
TIGS-1	Acceptable Tektronix 401X Defaults	TIGS-5	UNISTRUC II-8 UPLOT Offline Plot	UNISTRUC II-11
TIGS-2	Figure Displayed on Terminal Types 5 through 9	TIGS-5	UNISTRUC II-9 UPLOT Verification "Verify Errors"	UNISTRUC II-12
TIGS-3	Figure Displayed on Terminal Types 1 or 3	TIGS-6	UNISTRUC II-10 UNISTRUC and Application Translators	UNISTRUC II-13
TIGS-4	Acceptable Chromatics Defaults	TIGS-9	UNISTRUC II-11 Bulk Data Translators	UNISTRUC II-14
TIGS-5	Figure Displayed on Chromatics 1599	TIGS-10	UNISTRUC II-12 UNISTRUC CAD Data Interface	UNISTRUC II-14
TIGS-6	Figure Displayed on Tektronix 4114	TIGS-13	UNISTRUC II-13 UNISTRUC Offline Plotting Interface	UNISTRUC II-15
UNIPILOT V3.1-1	VERPROG INFORM	UNIPILOT-4	UNISTRUC II-14 UNISTRUC File Usage	UNISTRUC II-15
UNIPILOT V3.1-2	Verification Plot	UNIPILOT-5		
UNIPILOT V3.1-3	Display Terminal	UNIPILOT-12		
UNIPILOT V3.1-4	Pedestal Switches	UNIPILOT-13		
UNIPILOT V3.1-5	Front View and Control Panel	UNIPILOT-13		
UNIPILOT V3.1-6	Controller External Switches, Indicators and Connectors	UNIPILOT-13		

TABLES

UNIPL0T V3.1-1	UNIPOST Communications Capabilities	UNIPL0T-2	UNIPL0T V3.1-5	MDHCF0 Input Format	UNIPL0T-10
UNIPL0T V3.1-2	UNIPL0T V3.1 Permanent Files	UNIPL0T-3	UNISTRUC II-1	UNISTRUC II Communications Capabilities	UNISTRUC II-1
UNIPL0T V3.1-3	Verification "VERIFY ERRORS"	UNIPL0T-5	UNISTRUC II-2	UNISTRUC II Permanent Files	UNISTRUC II-5
UNIPL0T V3.1-4	DHCFILF Organization	UNIPL0T-10			

APEX-IV

APEX-IV V1.0

RELEASE DESCRIPTION

APEX-IV V1.0 runs under NOS 2 and includes Mixed Integer Programming, Matrix Reduction, and Parametric Programming features in binary format on REL57H.

Hardware Requirements

APEX-IV V1.0 requires the same minimum hardware configuration as NOS 2 except that a minimum field length of 104K octal is required for execution of APEX-IV.

Release Materials

REL57H contains the APEX-IV V1.0 system. It has the following characteristics: 7-track with 800 characters per inch (cpi) or 9-track with either 800 or 1600 cpi, binary recording mode, APEXIVV1P0 as file ID in HDR1 label, and six files.

- File 1 - installation and verification procedure,
- File 2 - absolute binary code,

- File 3 - overlay binary code for USER feature,
- File 4 - program library for USER feature,
- File 5 - relocatable binary code for USER feature, and
- File 6 - sample output from installation verification runs.

INSTALLATION AND VERIFICATION PROCEDURE

APEX-IV V1.0 is installed under user number APPLLIB and verified by entering the following commands at the system console after mounting REL57H.

```
X.DIS.  
SUL,377774.  
LABEL,TAPE,L=APEXIVV1P0,D= $\begin{pmatrix} \text{HY} \\ \text{HD} \\ \text{PE} \end{pmatrix}$ ,VSN=REL57H.  
COPYBF,TAPE,INSTALL.  
BEGIN,INSTALL,INSTALL.
```

The procedure results in four files being added to user number APPLLIB: APEXIV, APEXOV, APEXPL and APEXRL. These four files must be absent on user number APPLLIB when the procedure is begun. The procedure also executes four verification runs and copies sample verification run output from file 6 of REL57H for use in validating correct execution of the verification runs.

APT IV 2

APT IV V2

GENERAL DESCRIPTION

APT IV is a numerical control language processor designed to generate cutter location coordinates. The user has the capability to fully describe the part to be machined and drive the tool along the chosen path. The output from APT IV is a verification listing and a file for input to a postprocessor. APT IV V2 has all the capabilities of APT IV V1 in addition to new language features and extensions.

APT IV V2 runs under NOS 2 on a Control Data host computer having at least 65,000 words of central memory.

RELEASE MATERIALS

APT IV for NOS 2 is contained on release tape REL71. The structure of REL71 is as follows:

- File 1 - contains procedure file used to install APT IV with sculptured and parametric surface capabilities,
- File 2 - absolute binaries; copied onto permanent files by the install procedure,
- File 3 - empty,
- File 4 - empty,
- File 5 - verify job in update format,
- File 6 - verify output,
- File 7 - example procedure to install user's postprocessor,
- File 8 - relocatable binaries needed for installation of user's postprocessor, and
- File 9 - library file necessary for installing user's postprocessor.

Tape characteristics are 7-track with 800 characters per inch (cpi) or 9-track with either 800 or 1600 cpi, binary mode.

INSTALLATION REQUIREMENTS

APT IV release requires NOS 2; parametric and sculptured surface processing requires approximately 135,000g words execution on the NOS 2 system.

INSTALLATION PROCEDURE

The following control statements obtain a copy of the installation procedure and verification deck from REL71.

```
IVGET,T100.
USER.(user supplied)
LABEL(OLDPL,R,VSN=REL71,L=APT4*NOS1P0,
      PO=U,D={
              HY
              HD
              PE
            })
COPYSBF(OLDPL,OUTPUT,1)
SKIPF(OLDPL,3)
UPDATE(F,L=7,R,*==)
UNLOAD(OLDPL)
7/8/9 (multi-punched in column 1)
6/7/8/9 (multi-punched in column 1)
```

To install APT IV, the following commands must be entered from the console.

```
X.DIS.
SUI,377774.
LABEL(TAPE,R,VSN=REL71,L=APT4*NOS1P0,
      D={
        HY
        HD
        PE
      })
REWIND(TAPE,INSVER)
COPYBF(TAPE,INSVER)
BEGIN,,INSVER.
DROP.
```

VERIFICATION

To verify APT IV installation, the following job may be run. (The verification job will automatically be run after installation of APT IV.)

```
VERIFY,T20.
USER.(USER SUPPLIED)
LABEL(OLDPL,R,VSN=REL71,L=APT4*NOS1P0,
      D={
        HY
        HD
        PE
      })
SKIPF(OLDPL,4)
UPDATE(Q,*==,R)
ROUTE(COMPILE,DC=IN)
7/8/9 (multi-punched in column 1)
=IDENT VER
=DELETE VER.3
USER.(USER SUPPLIED)
=C VERDECK
7/8/9 (multi-punched in column 1)
6/7/8/9 (multi-punched in column 1)
```

POST PROCESSOR

To aid in the installation of a user postprocessor, a procedure is provided on file 7. Files 8 and 9 of the tape are necessary binary files for installing a user's postprocessor. To obtain a copy of file 7, the following job should be run.

```
PPGET,T50.  
USER, (user provided)  
LABEL(OLDPL,R,VSN=REL71,L=APT4*NOS1P0,  
D= {  
  HY  
  HD  
  PE  
})  
SKIPF(OLDPL,6)  
COPYSBF(OLDPL,T)  
DISPOSE(T=PR)  
7/8/9 (multi-punched in column 1)  
6/7/8/9 (multi-punched in column 1)
```

The procedure resides on an indirect access file INSTLPP. To invoke the procedure with a job, the following control cards should be used.

```
BEGIN,,INSTLPP,POSTCOM,POSTPEM.
```

POSTCOM is postprocessor source that resides on a direct access permanent file, and POSTPEM is the direct access permanent file name that will have the absolute binaries of the postprocessor.

NOTE

Postprocessor will be installed on user number, APPLLIB.

Notes and Cautions

Only permanent file APT4 must be attached from user number APPLLIB. This file is an execute only file. To attach the file, the following control card should be used.

```
ATTACH,APT4/UN=APPLLIB,M=E.
```

See the APT4 reference manual (publication number 17326900) for executing APT4.

CDC SYNTHAVISION PRODUCTS

GENERAL DESCRIPTION

CDC SynthaVision^{®†} allows on-line creation of three dimensional (3D) solid models. These models may be output as line drawings or color-shaded pictures and their mass properties may be calculated. In addition, edge files can be created and converted to IGES format. CDC SynthaVision consists of two products:

1. Interface Package
2. Image/Analysis Package

CDC SYNTHAVISION INTERFACE PACKAGE

RELEASE DESCRIPTION

The Interface Package is used for on-line creation of 3D solid models. This includes the ability to preview wire-frame representations of the model as it is being created and to postprocess the line drawings, color-shaded pictures, edge files, and mass properties information coming from the Image/Analysis Package so that this information can be viewed interactively.

Hardware Requirements

The Interface Package requires the same minimum hardware configuration as NOS 2 and NAM/IAF. A field length of 70K octal is required for execution. Any alphanumeric terminal may be used for the modeling process. Line drawings, edge files, wire-frame previews, and mass properties information may be viewed on a Tektronix 401X terminal. Line drawings, edge files, wire-frame previews, mass properties, and color-shaded pictures may be viewed on an Advanced Electronics Design 512 color terminal.

Release Materials

The Interface Package resides on release tape REL73A. REL73A has the following characteristics: 7-track with 800 characters per inch (cpi) or 9-track with either 800 or 1600 cpi, and binary recording mode. REL73A has CDCSVMODELER as its file ID in HDR1 label and six files described below.

- File 1 - procedure file used to install the Interface Package,
- File 2 - absolute binaries of the Interface Package,
- File 3 - absolute binaries of the library conversion program,

- File 4 - message file for Interface Package,
- File 5 - verification procedure for the Interface Package,
- File 6 - input file for verification procedure in file 5.

INSTALLATION REQUIREMENTS

The Interface Package requires NOS 2 with the Usage Pricing Utility for those customers who require that feature. NAM/IAF is required for on-line modeling.

INSTALLATION PROCEDURE

The Interface Package is installed by executing the procedure contained on file 1 of REL73A. The following commands must be entered from the system console.

```
X.DIS.  
SUI, 377774.  
LABEL(TAPE 1, VSN = REL73A, L=CDCSVMODELER,  
D = { HY } . HY=7-track, 800 cpi  
      { HD } . HD=9-track, 800 cpi  
      { PE } . PE=9-track, 1600 cpi  
COPYBF, TAPE 1, INSTALL.  
INSTALL.
```

VERIFICATION PROCEDURE

Before this verification can be performed, an indirect access file named USER, which contains a valid user number, password, and charge number, must be created. This file is used by the verification procedure to submit a job which executes the Image/Analysis Package. The contents of the file USER should look like the following:

```
JOB,T1000.  
USER, username, password.  
CHARGE, chargenum, projectnum.
```

The following job extracts the procedure VERMDL from REL73A and then executes VERMDL to verify the installation of the Interface Package and the Image/Analysis Package. The Image/Analysis Package on REL73B must be installed before this verification procedure is executed. This verification can be done at any alphanumeric terminal, at a Tektronix 401X terminal, or at an AED 512 color terminal.

[†]Registered trademark of the Mathematical Applications Group, Inc.

```

VER, T777.
USER (*)
CHARGE (*)
LABEL (TAPE 1, VSN = REL73A, L = CDCSVMODELER,
D = { HY } ) { HY=7-track, 800 cpi }
  { HD } ) { HD=9-track, 800 cpi }
  { PE } ) { PE=9-track, 1600 cpi }
SKIPF (TAPE 1, 4)
COPYBF,TAPE 1, VERMDL.
VERMDL, LIN } LIN = Verification on a Tektronix
              } 401X terminal
              } SHD = Verification on an AED 512
              } color terminal
              } MAS = Verification on any
              } alphanumeric terminal
              } VEW = Verification on a Tektronix
              } 401X terminal

```

Figure CDCSV-1 shows LIN. Figure CDCSV-2 shows MAS.

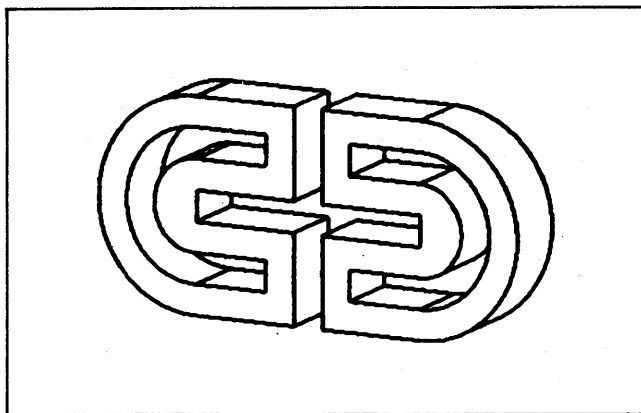

Figure CDCSV-1. Output Received from Running the Verification on a Tektronix 401X Terminal

```

MECHANICAL PROPERTIES
VOLUME 1.0914E+03 WEIGHT 1.0914E+03

GLOBAL CARTESIAN COORDINATE SYSTEM
CENTER OF GRAVITY
X -2.9999E-01 Y 1.3206E-01 Z 2.4977E+00

CENTROIDAL COORDINATE SYSTEM
PLANAR MOMENTS OF INERTIA
YZ 7.8893E+04 XZ 1.9585E+04 XY 2.2692E+03
AXIAL MOMENTS OF INERTIA
XX 2.1854E+04 YV 8.1162E+04 ZZ 9.8478E+04
AXIAL RADII OF GYRATION
XX 4.4747E+00 YV 8.6233E+00 ZZ 9.4988E+00
PRODUCTS OF INERTIA
YZ -4.7378E-01 XZ 1.1511E+01 XY 7.0893E+02
POLAR MOMENT OF INERTIA 1.0875E+05
POLAR RADIUS OF GYRATION 9.6076E+00

DIRECTION COSINES OF PRINCIPAL AXES AXIAL MOMENTS OF INERTIA
-.0002 .0000 1.0000 9.8478E+04
.0120 -.3999 .0000 8.1178E+04
.9999 .0120 .0002 2.1846E+04

NO ADDITIONAL COORDINATE SYSTEMS

--- ELAPSED CP TIME * 52.660 SECONDS
15:19

```

Figure CDCSV-2. Output Received from Running the Verification on Any Alphanumeric Terminal

Notes and Cautions

The Image/Analysis Package on REL73B must be installed before either the Interface Package or the Image/Analysis Package can be verified. Both packages are verified with the verification procedure contained on the Interface Package release tape REL73A.

The following files on APPLLIB will be replaced by the Interface Package installation procedure.

```

SYNTH (Direct Access File)
SVMSG (Direct Access File)
SVIGS (Direct Access File)
SVREFMT (Direct Access File)

```

CDC SYNTHAVISION IMAGE/ANALYSIS PACKAGE

RELEASE DESCRIPTION

This package contains the binary code for the part of the CDC SynthaVision system that analyzes the created model and produces one of four different types of output: a shaded picture, a line-drawing, an edge file, or various mass properties.

Hardware Requirements

The Image/Analysis programs require the same minimum hardware configuration as NOS 2. A field length of 177K octal is required for their execution.

Release Materials

The Image/Analysis Package resides on release tape REL73B. REL73B has the following characteristics: 7-track with 800 characters per inch (cpi) or 9-track with either 800 or 1600 cpi, and binary recording mode. REL73B has CDCSVANALYSIS as its file ID in HDR1 label and two files:

- File 1 - procedure file to install the Image/Analysis Package,
- File 2 - absolute binaries of the Image/Analysis Package.

INSTALLATION REQUIREMENTS

The Image/Analysis Package requires NOS 2 with the Usage Pricing Utility. The Usage Pricing Utilization and report generating programs (contained on REL70) are not required for installation but are required for tracking and reporting usage data.

INSTALLATION PROCEDURE

The Image/Analysis Package is installed by executing the procedure file contained on the first file of REL73B. The following commands must be entered from the system console.

X.DIS.

SUI,377774.

LABEL (TAPE 1, VSN = REL73B, L = CDCSVANALYSIS,

D = $\left. \begin{array}{l} \text{HY} \\ \text{HD} \\ \text{PE} \end{array} \right\}) \left\{ \begin{array}{l} \text{HY}=7\text{-track, 800 cpi} \\ \text{HD}=9\text{-track, 800 cpi} \\ \text{PE}=9\text{-track, 1600 cpi} \end{array} \right\}$

COPYBF, TAPE 1 INSTALL.

INSTALL.

VERIFICATION PROCEDURE

The files on this tape must be used in conjunction with the files on release tape REL73A. The verification of this tape is included as part of the verification procedure on REL73A. There is no separate verification procedure on the Image/Analysis Package release tape (REL73B).

Notes and Cautions

The following files on APPLIB will be replaced by the Image/Analysis Package installation procedure.

SVDBG (Direct Access File)
SVMAS (Direct Access File)
SVPIC (Direct Access File)
SVEDG (Direct Access File)
SVSRF (Direct Access File)
SVVEW (Direct Access File)

CD/2000 PACKAGE V1.4

RELEASE DESCRIPTION

CD/2000 is a computer-aided design and computer-aided manufacturing (CAD/CAM) system that runs under the NOS 2 and NAM/IAF communications package, and contains the usage pricing capability for those customers who require that feature.

Basic Package

The CD/2000 file contains overlays for Basic Geometry, Mechanical Drafting, and Geometric Analysis.

Extended Geometry Package

The CD/2000 with Extended Geometry consists of all the overlays in the Basic Package plus additional overlays for Extended Geometry.

Numerical Control (N/C) Package

The CD/2000 package with Numerical Control (N/C) consists of all overlays in the Basic Package and the Extended Geometry Package, plus additional overlays for Numerical Control.

Hardware Requirements

CD/2000 requires the minimum hardware configuration for NOS 2 and NAM/IAF. A field length of 110K octal is required for execution. User station is Tektronix 4014 or 4016 with Extended Graphics, Tektronix 4114.

Release Materials

CD/2000 Basic Package resides on tape REL68.

CD/2000 Extended Geometry Package resides on tape REL68A.

CD/2000 Numerical Control Package resides on tape REL68B.

Tape characteristics are 7-track with 800 characters per inch (cpi) or 9-track with either 800 or 1600 cpi, and binary recording mode.

CD/2000, on tape REL68, REL68A, or REL68B has seven files.

- File 1 - installation procedure file for CD/2000,
- File 2 - absolute binaries for CD/2000 zero overlay and primary overlays,

- File 3 - empty,
- File 4 - empty,
- File 5 - verification procedure file,
- File 6 - verification input file,
- File 7 - modifications to Communication Control Program (CCP).

INSTALLATION PROCEDURE

Complete the following steps to install CD/2000.

1. Ready the terminal according to the appropriate procedure in Terminal Setup Procedures in this section.
2. Log in to NOS with a valid family name, user name, password, and charge number. The terminal must be communicating through NAM/IAF using an asynchronous line.
3. Choose one of the following released mathematical packages.
 - Basic Package (vsn of REL68 and a file identifier of CD2KBASE).
 - Extended Geometry Package (vsn of REL68A and a file identifier of CD2KEXTG).
 - Numerical Control Package (vsn of REL68B and a file identifier of CD2KNC).
4. Install the chosen mathematical package by entering the following commands. Be sure that the parameter values entered for VSN and L correspond to the vsn and file identifier of the chosen package.

LABEL,TAPE, $\left\{ \begin{array}{l} \text{VSN=REL68} \\ \text{VSN=REL68A} \\ \text{VSN=REL68B} \end{array} \right\}, \left\{ \begin{array}{l} \text{L=CD2KBASE} \\ \text{L=CD2KEXTG} \\ \text{L=CD2KNC} \end{array} \right\},$

D= $\left\{ \begin{array}{l} \text{HY} \\ \text{HD} \\ \text{PE} \end{array} \right\} \cdot \left\{ \begin{array}{l} (7\text{-track, 800 cpi}) \\ (9\text{-track, 800 cpi}) \\ (9\text{-track, 1600 cpi}) \end{array} \right\}$

COPYBF,TAPE,INSTALL.
INSTALL.

5. Log off the system by entering BYE.

INSTALLATION VERIFICATION

1. Log in to NOS with a valid family name, user name, password and, if required, a charge number. The terminal must be communicating through NAM/IAF using an asynchronous line.
2. Enter:

GET,CD2KVER/UN=username.

UN=username specifies the user name under which CD/2000 was installed. Omit this parameter (and the slant) if you are verifying the installation under the same user name used for installing CD/2000.

CD2KVER is a procedure file, which attaches the CD/2000 verification program and CD/2000 permanent file.

3. Enter:

CD2KVER,baudnumber,username.

baudnumber specifies the first digit of the baud rate of the communications line. For example, 3 is the baudnumber for a baud rate of 300, and 1 is the baudnumber for a baud rate of 1200.

username specifies the user name under which CD/2000 was installed. Omit this parameter if you are verifying the installation under the same user name that you used for installing CD/2000.

Ignore the CD/2000 requests for input. The input is supplied by the verification input file. The result should match the display shown in figure CD/2000-1.

4. Log off the system by entering BYE.

TERMINAL SETUP PROCEDURES

The terminal that will be used for the installation of CD/2000, CD/2000-to-IGES translator, IGES-to-CD/2000 translator, and ASCII-display code editing utility must be set up. Instructions for setting up the 4014, 4016, and 4114 Tektronix terminals follow.

TEKTRONIX 4014/4016 TERMINALS

1. The following terminal strapping options are for initial terminal installation.
 - a. ECHO - ON
 - b. GIN terminators - CR only
 - c. CR effect - CR
 - d. LF effect - LF
2. Turn the terminal power on. The 4014 POWER switch is on the front lower right corner of the pedestal stand. The 4016 POWER switch is located on the right side of the terminal head. The green POWER indicator, located on the keyboard, will light when power is switched on.
3. Allow the terminal to warm up. Warmup is complete when pressing the RESET PAGE key completely clears the screen.
4. Set the ASCII/ALT switch to the ASCII position.
5. Initialize the OPTION 1 or OPTION 20 according to the procedure below, as applicable.
6. To obtain the small character size, set the terminal to LOCAL mode. Press the ESC key and the ; (semicolon) key together and return to LINE mode.



Figure CD/2000-1. Verification Display

7. Dial the appropriate telephone number, if applicable.
8. Press the RETURN key to obtain the login FAMILY message.

OPTION 1 INITIALIZATION

1. Select the appropriate baud rate switch setting using the BAUD RATE switch located at the rear of the pedestal stand.
2. Set the HALF/FULL DUPLEX switch to FULL.
3. Set the INTF/OFF/AUX switch to INTF.
4. Set the TTY LOCK key.

OPTION 20 INITIALIZATION

NOTE

If the terminal is equipped with both the OPTION 1 and the OPTION 20, set the INTF/OFF/AUX switch of the OPTION 1 to OFF.

1. Asynchronous lines only. Place the terminal in LOCAL mode. Press the SHIFT key and the CNTL key together. While both the SHIFT and CNTL keys are depressed, press and release the RESET key; then press the P key and release all keys. Place the terminal in LINE mode. Set the CODE EXPANDER switch to OFF.
2. Synchronous lines only. Place the terminal in LOCAL mode. Press the SHIFT key and the RESET key together. Place the terminal in LINE mode. Press the SHIFT key and the RESET key together. Set the CODE EXPANDER switch to ON. (Note that RUBOUT replaces BACKSPACE in synchronous mode.)

TEKTRONIX 4114 TERMINALS

Complete the following to set up the Tektronix 4114 terminal.

1. Turn the terminal power on by pushing the POWER button, which is located above the keyboard on the base pedestal.
2. Allow the terminal to initialize (some keys on the keyboard remain lit until the terminal has completed its initialization).
3. Press the SET UP key so that the terminal operating modes can be changed at the keyboard. An asterisk (*) should appear to the left of the cursor.
4. Enter:

STA

to display the released terminal status settings.

† Enter the applicable baud rate (from 300 through 9600).

5. Ensure that the terminal has the following settings (to change a setting, just reenter it).

```
TBSTATUS OUT
TBHEADERCHARS CONTROL
REOM 1
RLINELENGTH 140
PAGEFUL NONE
ECHO YES
LOCKKEYBOARD NO
IGNOREDEL NO
LFCR NO
CRLF NO
SNOOPY NO
BAUDRATE†
QUEUESIZE 8100
FLAGGING IN/OUT
EOLSTRING CRLF
BLOCKMODE NO
```

The remaining Tektronix 4114 terminal status settings will either be set by CD/2000 or will have no bearing on the operation of CD/2000.

NOTES AND CAUTIONS

1. CD/2000 verification procedure runs on asynchronous lines only.
2. The verification procedure makes the verification output on a Tektronix 4114 terminal emulate the output of a Tektronix 4014 terminal.
3. It is recommended the installation use GENSYS, as described in the NOS Installation Handbook, to avoid reinstalling CD/2000 at every deadstart.

CD/2000 UTILITY PACKAGE

The CD/2000 Utility Package provides the user with three capabilities. First, the package allows the user to interface CD/2000 drawing files with UNIPLOT. Second, the package includes the necessary mesh generator interface routines to generate a CD/2000 line file as input to a mesh generator. Third, the package includes the IGES-CD/2000 translators that will allow the user to translate data between IGES and CD/2000 files.

RELEASE MATERIALS

CD/2000 Utility Package resides on tape REL68E.

Tape characteristics are 7-track with 800 cpi or 9-track with either 800 or 1600 cpi, and binary recording mode.

CD/2000 Utility Package on tape REL68E has a file ID in HDR1 label of CD2KUTIL and has 17 files.

- | | |
|--------|---|
| File 1 | - procedure for installing the utility used to interface CD/2000 draw files to UNIPLOT, |
| File 2 | - used to interface CD/2000 draw files to UNIPLOT, |
| File 3 | - verification procedure for the utility used to interface CD/2000 draw files to UNIPLOT, |
| File 4 | - CD/2000 input for the utility used to interface CD/2000 draw files to UNIPLOT, |

- File 5 - plotter optimization utility (absolute binaries),
- File 6 - empty,
- File 7 - empty,
- File 8 - copy utility (absolute binaries) COPYLDR,
- File 9 - procedure to install and to verify the IGES-CD/2000 translators,
- File 10 - CD/2000-to-IGES translator routines (absolute binaries),
- File 11 - CD/2000-to-IGES translator initialization procedure file, IGESCI,
- File 12 - IGES-to-CD/2000 translator routines (absolute binaries),
- File 13 - IGES-to-CD/2000 translator initialization procedure file, IGESIC,
- File 14 - CD/2000-to-IGES verification file,
- File 15 - IGES-to-CD/2000 verification file,
- File 16 - ASCII-display code editing utility procedure file, IGES EDT, and
- File 17 - ASCII-display code editing utility absolute binary, IGES ED.

When verification occurs, UNIPOST will ask the following:

AUTOMATIC HARDCOPY (Y/N)
?

Specify N for no.

Next, UNIPOST will ask:

1. 4010 SYNCHRONOUS
 2. 4010 ASYNCHRONOUS
 3. 4014 SYNCHRONOUS
 4. 4014 ASYNCHRONOUS
 5. 4014 EGM SYNCHRONOUS
 6. 4014 EGM ASYNCHRONOUS
- ENTER TERMINAL TYPE, 1 THRU 6
?

Specify 1 through 6 depending on the Tektronix terminal type.

ENTER BAUD RATE
?

Enter the baud rate (example, 300 for 300 baud, or 9600 for 9600 baud).

1 UNIPOST V2.1 INPUT DIRECTIVES
?

Hit the carriage control. (There are no UNIPOST directives.) Refer to UNIPLOT Reference Manual, for additional information.

The display in figure CD/2000-1 will be drawn on the lower left corner of the terminal screen, half scale, and without the CD/2000 prompts on the upper corner.

When the figure has been drawn, crosshairs should appear. Hit any key (A through Z), and the screen will clear. Continue to do this until the crosshairs no longer appear and control has returned to NOS. The cursor will be enlarged.

UNIPLOT UTILITY INSTALLATION AND VERIFICATION PROCEDURES

To get a listing of the verification procedure and the installation procedure, execute the following job.

```
LIST,T50.
USER,username,password,familyname.
CHARGE,*
LABEL,TAPE,R,VSN=REL68E,L=CD2KUTIL,D= { HY
                                         HD
                                         PE } .
COPYSBF,TAPE,OUTPUT.
SKIPF,TAPE,3.
COPYSBF,TAPE,OUTPUT.
--eoi--
```

VERIFICATION PROCEDURE

To rerun the verification procedure for the utility that interfaces the CD/2000 draw file to UNIPLOT, repeat the following steps:

INSTALLATION PROCEDURE

To install the CD/2000 utility used to interface the CD/2000 draw file to UNIPLOT, complete the following procedure.

1. Ensure that the terminal is ready; refer to Terminal Setup Procedures.
2. Log in to NOS with a valid family name, user name, password and, if necessary, charge number.
3. Enter the following commands.

```
LABEL,TAPE,R,VSN=REL68E,L=CD2KUTIL,
D= { HY
    HD
    PE } .
COPYBF,TAPE,INUTIL.
INUTIL,username.
```

Procedure INUTIL will also verify the installation of the CD/2000 utility package used to interface CD/2000 draw files to UNIPLOT.

1. Ensure that the terminal is ready; refer to Terminal Setup Procedures.
2. Log in to NOS with a valid family name, user name, password, and charge number.
3. Enter the following commands.

```
LABEL,TAPE,R,VSN=REL68E,L=CD2KUTIL,
D= { HY
    HD
    PE } .
SKIPF,TAPE,4.
COPYBF,TAPE,VERUTIL.
VERUTIL,username.
```

Refer to Installation Procedure for responses to UNIPOST questions.

NOTE

The verification file runs on asynchronous lines only. Refer to Notes and Cautions.

Notes and Cautions

The verification procedures for the interface to UNIPLOT assumes:

The verification procedure that interfaces CD/2000 draw files and UNIPLOT assumes UNIPLOT and UNIPOST are direct access files in the LIBRARY catalog.

IGES-CD/2000 TRANSLATORS INSTALLATION AND VERIFICATION PROCEDURES

To install the CD/2000-to-IGES translator, the IGES-to-CD/2000 translator, and the ASCII-display code editing utility, execute the following procedures.

1. Refer to Terminal Setup Procedures to properly set up the graphics terminal for the translators installation and verification.
2. Log in to NOS with a valid family name, user name, password, and if necessary, a charge number.
3. Enter the following commands to obtain the IGES-CD/2000 translators installation-verification procedure file.

```
LABEL,TAPE,R,VSN=REL68E,L=CD2KUTIL,  
D= { HY }  
   { HD }  
   { PE }  
REWIND,TAPE.  
SKIP,TAPE,8.  
COPYBF,TAPE,INSTAL.
```

4. Refer to figure CD/2000-2 for a listing of the INSTAL procedure file. Edit the INSTAL procedure file to:
 - a. Replace the two occurrences of the word BAUDRATE with the baud rate that will be used for the installation and verification of the translators (for example 1 for 1200 baud).
 - b. Replace the command that attaches CD/2000 with a command that is appropriate for the NOS 2 operating system on which the translators are being installed.
5. Initiate the installation/verification procedure file by entering:

INSTAL

The INSTAL procedure file will install and verify the translators and the corresponding translator initiation procedure files.

6. After the INSTAL procedure file has completed execution, examine the DAYFILE. (Translator errors will be written to the DAYFILE of the translation job.) If the translation process has completed without DAYFILE errors and figure CD/2000-3 was displayed on the terminal screen when the INSTAL procedure file completed execution, then the translators have been successfully installed. (The message INSTAL PROCEDURE FILE EXECUTION COMPLETE will be displayed when the installation/verification has been completed).

```
.PROC,INSTAL.  
RETURN,TAPE3.  
REWIND,TAPE.  
SKIP,TAPE,9.  
DEFINE,IGESCIT/UN=APPLLIB,M=E.  
DEFINE,IGESICT/UN=APPLLIB,M=E.  
DEFINE,IGESED/UN=APPLLIB,M=E.  
COPYBF(TAPE,IGESCIT)  
COPYBF(TAPE,IGESCI)  
COPYBF(TAPE,IGESICT)  
COPYBF(TAPE,IGESIC)  
REPLACE,IGESCI/UN=APPLLIB.  
REPLACE,IGESIC/UN=APPLLIB.  
COPYBF(TAPE,IGESCIV)  
COPYBF(TAPE,IGESICV)  
COPYBF(TAPE,IGESDIT)  
COPYBF(TAPE,IGESED)  
REPLACE,IGESDIT/UN=APPLLIB.  
REWIND,*.  
ATTACH(CD/2000/UN=APPLLIB/M=E)  
CD2000(BAUDRATE,I=IGESCIV)  
RETURN,IGESICT,IGESCIT.  
REWIND,IPARTD.  
NOTE,,NR. \ CD/2000 TO IGES TRANSLATOR VERIFICATION\  
BEGIN,CI,IGESCI,FT=LOC.  
RETURN,IPARTD.  
REWIND,IGES.  
NOTE,,NR. \ IGES TO CD/2000 TRANSLATOR VERIFICATION\  
BEGIN,IC,IGESIC,FT=LOC.  
REWIND,IPARTD.  
RETURN,TAPE3.  
CD2000(BAUDRATE,I=IGESICV)  
NOTE,,NR. \ INSTAL PROCEDURE FILE EXECUTION COMPLETE\
```

Figure CD/2000-2. Listing of the INSTAL Procedure File

The installation/verification procedure file will create the following files.

Indirect access files:

- IGESCI - CD/2000-to-IGES translator procedure file.
- IGESIC - IGES-to-CD/2000 translator procedure file.
- IGESDT - ASCII-display code utility procedure file.

Direct Access files:

- IGESCIT - CD/2000-to-IGES translator.
- IGESICT - IGES-to-CD/2000 translator.
- IGESD - ASCII-display code utility.

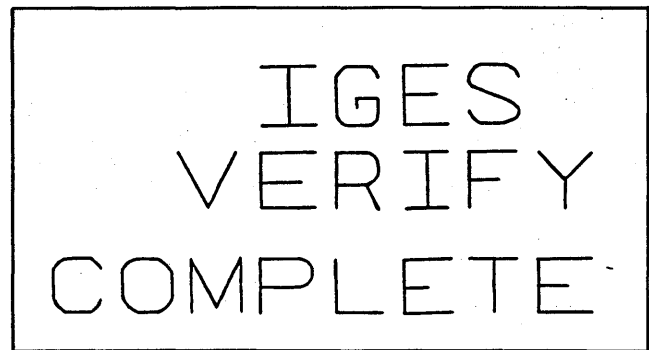

Figure CD/2000-3. Installation/Verification Display

ENGINEERING DATA LIBRARY

RELEASE DESCRIPTION

Engineering Data Library (EDL) is an application designed to manage and update engineering data and its applications. The EDL system runs under NOS 2 and the NAM/IAF communications package. IMF and QU packages interface to EDL but are not required.

HARDWARE REQUIREMENTS

EDL requires the minimum hardware configuration for NOS 2 and NAM/IAF. User station can be a graphic or alphanumeric terminal.

DEPENDENCIES

To use all the features of EDL, CD/2000 1.4 is required. This version of CD/2000 has code for automatic updating of EDL.

CDC SynthaVision 1.2 is required in order to use the boundary file creation capability and the CDC SynthaVision to Initial Graphics Exchange Specification (IGES) translation.

RELEASE MATERIALS

EDL resides on the tape labeled REL76. The tape characteristics are either 7-track with 800 characters per inch (cpi) or 9-track with 1600 cpi. Tape format is internal (F=I) and labeled (LB=KL). The tape has 17 files.

- File 1 - installation job,
- File 2 - EAEDL, overlay capsules for EDL,
- File 3 - EALOADM, an absolute program,
- File 4 - EALOGCD, an absolute program,
- File 5 - EAPREVC, an absolute program,
- File 6 - EAPREVS, an absolute program,
- File 7 - CDIN1, part of the input file for CD/2000,
- File 8 - CDIN2, part of the input file for CD/2000,
- File 9 - CDIN3, part of the input file for CD/2000,
- File 10 - CDIN4, part of the input file for CD/2000,

- File 11 - CDIN5, part of the input file for CD/2000,
- File 12 - CDIN6, part of the input file for CD/2000,
- File 13 - CDIN7, part of the input file for CD/2000,
- File 14 - EDL procedure for activating EDL,
- File 15 - EDLPROC, file containing the procedures needed by EDL,
- File 16 - EDLMETA, meta base of EDL, and
- File 17 - EDLDATA, data base of EDL.

INSTALLATION PROCEDURE

Define a user name for the EDL data base administrator. This user name is where the EDL data base will reside. Log in to NOS under this user name. Copy the first file from the tape using the following control statements.

```
REQUEST,T,NT,D=PE,F=I,LB=KL,VSN=REL76.  
COPYBF,T,EDLJOB,  
RETURN,T.
```

Edit file EDLJOB to change the default user name, password and the charge number to the ones for the data base administrator, then submit the EDLJOB with the control statement:

```
SUBMIT,EDLJOB,B.
```

This job copies all the EDL files to the data base administrator's user name. Edit file EDLPROC to attach the versions of CD/2000, CDC SynthaVision, and UNIPLOT that are on your system.

Edit files EDL and EDLPROC to change the user name from EDLDBA to the NOS user name defined for the data base administrator.

INSTALLATION VERIFICATION

To verify the installation of EDL, do the following steps:

1. Log in to NOS using the user name established for the data base administrator.
2. Initiate the verification procedure by entering:

```
-,EDL.
```

The system responds with a two-line header identifying EDL. The system then prompts for the EDL user identification.

3. Enter the user identification:

EDLID

Next the system prompts for the EDL password.

4. Enter the password:

DBA

The DBA Tasks menu is displayed (refer to figure EDL-1).

5. Enter the number 4 to select the User Profile Management menu. The User Profile Management menu is displayed (refer to figure EDL-2).
6. Enter the number 2 to select the Modify a User Profile option. The system then prompts for information concerning the site's data base administrator. The first prompt requests the new EDL user identification.
7. Enter the EDL user identification,

EDLID

The system displays 12 additional prompts so that the data base administrator is uniquely identified. Enter the appropriate response for each prompt. The information the prompts request are the user's:

- NOS user name under which EDL was installed.
- Department number.
- Password.
- Manager EDL identification.
- First, middle, and last names.
- Title.
- Office address including city and zip code.
- Office phone number.

The last prompt asks if the new user is also a releaser. (Respond with NO.)

8. Press (CR) for the ENTER NEW EDL USER IDENTIFICATION prompt after the description of the administrator has been entered. The system responds by displaying the User Profile Management menu.
9. Enter the number 5 to exit from that menu. The DBA Tasks menu is then displayed.
10. Enter the number 6 to display the Reports menu (refer to figure EDL-3).
11. Enter the number 4 to select the User Report option. The next prompt asks if reports are wanted for a particular user, all users, or no users.

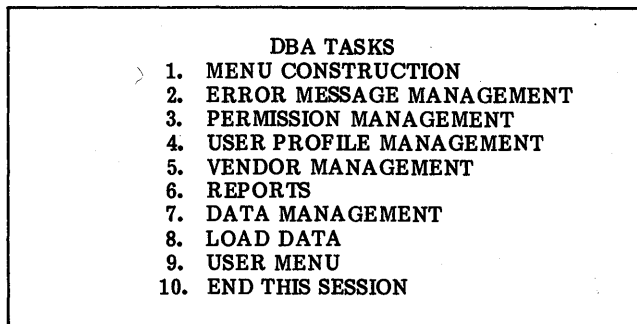

Figure EDL-1. DBA Tasks Menu

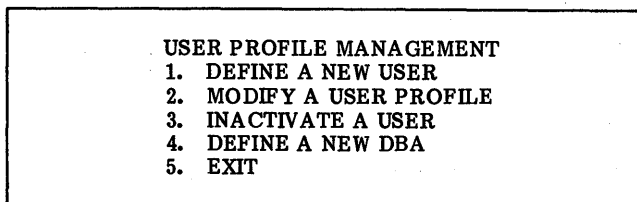

Figure EDL-2. User Profile Management Menu

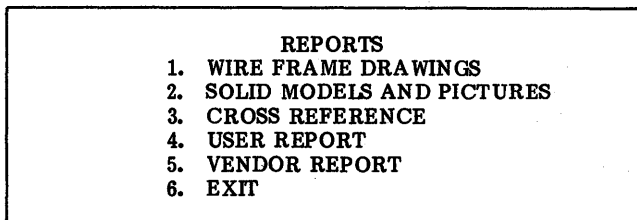

Figure EDL-3. Reports Menu

12. Enter:

ALL

Next the system requests the output medium desired (CRT, printer, or file).

13. Enter 1 to display the reports at the terminal.

The next two prompts ask the range of user identifications on which to make the user reports.

14. Press (CR) for both the ENTER LOWER RANGE OR CR FOR FIRST and ENTER UPPER RANGE OR CR FOR ALL prompts to receive the user reports on the data base administrator.

The user report is then displayed at the terminal.

Verify that the user report is correct for the data base administrator. A sample report is in figure EDL-4. If there are any errors in the report, perform step 15 and then start over at step 5 to correct the errors.

15. Enter the number 6 to leave the Reports menu. The system then displays the DBA Tasks menu.
16. Enter the number 10 to leave the DBA Tasks menu and end the EDL session.

The system displays the Reports menu.

```
*****  
* EDL IDENTIFICATION: EDLID          TITLE: DATA BASE ADMINISTRA *  
*                                     *  
* NAME: ARORA                        D. K.      PHONE: 612-482-2353 *  
*                                     *  
* NOS ID: DBAEDL                     DEPARTMENT: 1702 *  
*                                     *  
*****
```

Figure EDL-4. Sample User Profile Report

GPSS V PRODUCTS

GPSS V V1.3.1

RELEASE DESCRIPTION

GPSS V V1.3.1 runs under NOS 2 and is designed to execute from permanent files.

Hardware Requirements

A minimum field length of 100K octal is required to load GPSS V. Once loaded, it requires a minimum field length of 100K octal to execute. Other requirements are the same as the minimum hardware configuration for NOS 2.

Release Materials

GPSS V is contained on the tape known as REL50A. REL50A has the following characteristics: 7-track with 800 characters per inch (cpi) or 9-track with either 800 or 1600 cpi, binary recording mode, GPSSV1P31 as file ID in the HDR1 label, and six files.

- File 1 - installation and verification procedure,
- File 2 - GPSS V absolute binaries,
- File 3 - empty,
- File 4 - empty,
- File 5 - empty, and
- File 6 - sample output from verification run.

A listing of the installation and verification procedure file may be obtained by running the following job.

```
LIST,T50.  
USER. (Supply valid user card.)  
LABEL,TAPE,R,L=GPSSV1P31,D= $\left\{ \begin{array}{l} \text{HY} \\ \text{HD} \\ \text{PE} \end{array} \right\}$ ,VSN=REL50A.  
COPYSBF,TAPE,OUTPUT.  
6/7/8/9
```

INSTALLATION PROCEDURE

The installation procedure file on file 1 of REL50A installs the GPSS V absolute binaries on a direct access, execute only, permanent file named GPSS. The procedure also executes a verification run and copies sample verification run output from the file 6 of REL50A for use in validating correct execution of the verification run.

To install GPSS V, the following job must be run from the system console:

```
X.DIS.  
SUI,377774.  
LABEL,TAPE,L=GPSSV1P31,D= $\left\{ \begin{array}{l} \text{HY} \\ \text{HD} \\ \text{PE} \end{array} \right\}$ ,  
VSN=REL50A.  
COPYBF,TAPE,INSTALL.  
BEGIN,,INSTALL.  
DROP.
```

Notes and Cautions

Permanent Files

The installation procedure file on file 1 of REL50A does not check for any existing file with the name GPSS. If a file already exists with this name, it must be purged or renamed.

Execute Only Files

GPSS is installed as a direct access, execute only permanent file. The following control card is required to attach it.

```
ATTACH,GPSS/UN=APPLLIB,M=E.
```

GTICES/STRUDL PRODUCTS

GTICES/STRUDL OVERVIEW

DESCRIPTION

GTICES/STRUDL assists an engineer in structural analysis and design of various types of structures. It is a sophisticated information processing system capable of supplying an engineer with accurate and complete technical data for structural design decision making.

GTTABLE provides for the creation and maintenance of a data base of tabular data which is made available to GTICES/STRUDL.

GTICES/STRUDL and GTTABLE are proprietary to the Georgia Institute of Technology.

GTICES/STRUDL

RELEASE DESCRIPTION

GTICES/STRUDL runs under NOS 2. The FDL processors LDD and LDQ are required for execution. GTICES/STRUDL is designed to execute from permanent files.

Hardware Requirements

GTICES/STRUDL requires the same minimum hardware configuration as NOS 2. A minimum field length of 100K octal is required for installation. Field length required for execution is upward from 120K octal. User access to extended core storage is not required but, if available, it can be utilized. GTICES/STRUDL is designed to execute from permanent files.

Release Materials

GTICES/STRUDL resides on the tape known as REL67C. REL67C contains absolute and relocatable binaries, user libraries, data files, and procedures necessary to load the GTICES/CDC system and GTICES/STRUDL. It has the following characteristics: 7-track with 800 characters per inch (cpi) or 9-track with either 800 or 1600 cpi, binary recording mode, GTICESV2M4 as file ID in HDR1 label, and 13 files.

- File 1 - installation procedure (CCL) and verification job,
- File 2 - absolute of GTICES/CDC Executive,

- File 3 - null,
- File 4 - null,
- File 5 - sample GTICES/STRUDL problem,
- File 6 - verification output for sample STRUDL problem in file 5,
- File 7 - GTICES/CDC System programs in user library format,
- File 8 - system and GTICES/STRUDL command definition blocks,
- File 9 - GTICES/STRUDL binaries in user library format,
- File 10 - GTICES/STRUDL permanent data base in GTICES/CDC internal format,
- File 11 - relocatable GTICES/CDC setup program,
- File 12 - interface program for accounting in user library format, and
- File 13 - STRUDL execution procedure (CCL).

Listings of the installation procedure, STRUDL execution procedure, sample problem, and verification output may be obtained from REL67C by executing the following job.

```
GTLIST,T100.  
USER,USERNAM,PASSWOR. (Supply a valid USER  
card.)  
LABEL(TAPE,VSN=REL67C,D= { HY } ,  
R,L=GTSTR8105) { HD }  
COPYSBF(TAPE)  
SKIPF(TAPE,3)  
COPYSBF(TAPE,OUTPUT,2)  
SKIPF(TAPE,6)  
COPYSBF(TAPE,OUTPUT,1)  
7/8/9  
6/7/8/9
```

INSTALLATION PROCEDURE

GTICES/STRUDL is installed by executing a job (described below) which invokes the CCL procedure contained in the first record of file 1 on the release tape REL67C. This job will copy the GTICES/CDC system and STRUDL to permanent files, then execute the GTICES/STRUDL sample

problem to verify the installation. The permanent files associated with each file on the release tape are:

<u>File</u>	<u>Name</u>	<u>Type</u>
1†		
2	GTICES	D/A, execute only
3	Null	
4	Null	
5†		
6†		
7	ICESLIB	D/A
8	CDBLIB	D/A
9	STRULIB	D/A
10	STRUDAT	D/A
11	ICESET	I/A, execute only
12	COSTLIB	I/A
13	STRUDL	I/A

Step 1

GTICES/STRUDL installation is effected by executing the following job at the system console:

```
X.DIS.
SUI,377774.
LABEL(TAPE,D= { HY
                HD
                PE },R,L=GTSTR8105,VSN=REL67C)
COPYBF(TAPE,INSTALL)
BEGIN(INSTALL)
DROP.
```

Step 2

The output listing created from this job contains:

- Listing from GTICES - install system and STRUDL command definition blocks,
- Listing from STRUDL - sample job,
- Listing from REL67C -verification output for sample job,
- The two STRUDL listings above can be compared to verify the installation run.

Notes and Cautions

The installation procedure will PURGE permanent files that match the GTICES/STRUDL names of GTICES, ICESLIB, CDBLIB, STRULIB, STRUDAT, ICESET, STRUDL, and COSTLIB.

GTTABLE

RELEASE DESCRIPTION

GTTABLE runs under the NOS operating system in conjunction with GTICES/STRUDL. The FDL processors LDD and LDQ are required for execution.

Hardware Requirements

GTTABLE requires the same minimum hardware configuration as NOS 2. A minimum field length of 100K octal is required for installation. Field length required for execution is upward from 120K octal. User access to extended core storage is not required but, if available, it can be utilized. GTTABLE is designed to execute from permanent files.

Release Materials

GTTABLE resides on the tape known as REL67D. REL67D contains user libraries, data files, and procedures necessary to load GTTABLE. It has the following characteristics: 7-track with 800 cpi or 9-track with either 800 or 1600 cpi, binary recording mode, GTTABLV2M4 as file ID in HDR1 label, and 10 files:

- File 1 - installation procedure (CCL) and verification job,
- File 2 - absolute of GTICES/CDC executive,
- File 3 - null,
- File 4 - null,
- File 5 - sample GTTABLE job,
- File 6 - verification output for sample GTTABLE problem in File 5,
- File 7 - GTTABLE binaries in user library format,
- File 8 - GTTABLE command definition blocks,
- File 9 - interface program for accounting in user library format, and
- File 10 - GTSTRUDL/GTTABLE execution procedure.

Listings of the installation procedure, GTTABLE execution procedure, sample problem and verification output may be obtained from REL67D by executing the following job.

```
GTLIST,T100.
USER,USERNUM,PASSWOR. (Supply a valid USER card.)
LABEL(TAPE,VSN=REL67D,D= { HY
                          HD
                          PE },
R,L=GTTAB8102)
COPYSBF(TAPE)
SKIPF(TAPE,3)
COPYSBF(TAPE,OUTPUT,2)
SKIPF(TAPE,3)
COPYSBF(TAPE,OUTPUT,1)
7/8/9
6/7/8/9
```

† Not retained on a permanent file.

INSTALLATION PROCEDURES

GTTABLE is installed by executing a job (described below) which invokes the CCL procedure contained in the first record of file 1 on the release tape REL67D. This job will copy GTTABLE to permanent files, then execute the GTTABLE sample problem to verify the installation. The permanent files associated with each file on the release tape are:

<u>File</u>	<u>Name</u>	<u>Type</u>
1 †		
2	GTICES2	D/A
3	Null	
4	Null	
5 †		
6 †		
7	TABLLIB	D/A
8	CDBLIB	D/A
9	COSTLB2	I/A
10	STRUDLT	I/A

GTTABLE installation is effected by executing the following job at the system console:

X.DIS.
SUI,377774.

```
LABEL(TAPE,D= { HY } ,R,L=GTTAB8102,  
              { HD }  
              { PE }  
VSN=REL67D)  
COPYBF(TAPE,INSTALL)  
BEGIN(INSTALL)  
DROP.
```

The output listing created from this job contains:

- Listing from GTICES - install system and GTTABLE command definition blocks,
- Listing from GTTABLE - sample job,
- Listing from REL67D - verification output for sample job.

The two GTTABLE listings above can be compared to verify the installation run.

Notes and Cautions

The installation procedure will PURGE permanent files which match the GTTABLE and/or GTICES/STRUDL names of TABLLIB, CDBLIB, STRUDLT, and COSTLB2.

†Not retained on a permanent file.

IMSL 9.0

RELEASE DESCRIPTION

IMSL (International Mathematical and Statistical Library, Version 9.0) consists of more than 490 user callable subroutines for FORTRAN 5. IMSL is on REL63.

Hardware Requirements

IMSL requires the minimum hardware configuration for NOS 2.

Notes and Cautions

The installation process does not provide program listings. If a program listing is needed (it is very long), the FTN card in the install deck may be appropriately modified (remove L=0).

Release Materials

IMSL is contained on the tape known as REL63. REL63 is a program library in Update format. It has the following characteristics: 7-track with 800 characters per inch (cpi) or 9-track with either 800 or 1600 cpi, binary recording mode, F=SI, and eight files:

- File 1 - installation and verification procedures,
- File 2 - empty file,
- File 3 - empty file,
- File 4 - program deck in UPDATE OLDPL format,
- File 5 - verify job control language deck in UPDATE OLDPL format,
- File 6 - expected verify output ((COPYBF, OUTPUT) format),

File 7 - verify program deck in UPDATE OLDPL format, and

File 8 - deleted routines from Version 8 in UPDATE PL format. (Included for conversion purposes.)

INSTALLATION PROCEDURE

Enter the following job to install IMSL. The procedure NOSINST puts the IMSL library on the direct access public file named IMSLIB. IMSLIB is cataloged under the user name you specify for the job.

```
JOB,T1000.  
USER,username,password,familyname.  
CHARGE,*.  
LABEL,TAPE,D={  
  HY  
  HD  
  PE  
},F=SI,VSN=IMSLIB.  
COPYBF,TAPE,IMSLPRC.  
BEGIN,NOSINST,IMSLPRC.
```

IMSL Version 9.0 deletes or replaces some of the FORTRAN 5 routines that were in IMSL Version 8.1. There are no routine name conflicts between version 9.0 and 8.1. If you want to have all the version 9.0 routines plus the version 8.1 routines, change the BEGIN command to the following.

```
BEGIN,NOSINST,IMSLPRC,ADDV8.
```

After IMSL is installed, verify its installation by entering the following job. If you also installed the IMSL Version 8.1 routines, this job does not verify their installation. This job executes IMSL test cases and prints both the expected and actual results of the tests. If the expected and actual test results are not identical, purge IMSLIB and reinstall IMSL.

```
JOB,T1000.  
USER,username,password,familyname.  
CHARGE,*.  
LABEL,TAPE,D={  
  HY  
  HD  
  PE  
},F=SI,VSN=IMSLIB.  
COPYBF,TAPE,IMSLPRC.  
BEGIN,NOSVFY,IMSLPRC.
```

IPF2

RELEASE DESCRIPTION

IPF2 (Information Processing Family Version 2) is an interactive data handling package that interfaces with indexed-sequential or sequential files. Functions that IPF2 performs include data definition, data entry and updating, data file query, report generation, data transformation, and data utilities. IPF2 executes on NOS 2.

HARDWARE REQUIREMENTS

IPF2 requires the same minimum hardware configuration as NOS 2, except that it requires a minimum field length of 200K octal.

RELEASE MATERIALS

IPF2 resides on the tape labeled REL76. The tape characteristics are 7-track with 800 characters per inch (cpi) or 9-track with either 800 or 1600 cpi, binary recording mode, IPF2V23 as file ID in the HDR1 label, and the following 63 files.

- File 1 - IPF2REL, installation procedure,
- File 2 - IPF2, main procedure for executing IPF2; it calls the procedures on files 3 through 9,
- File 3 - IP2CCL procedure,
- File 4 - I20CLM2 procedure,
- File 5 - I20CLR1 procedure,
- File 6 - I20CLT1 procedure,
- File 7 - I20CLE1 procedure,
- File 8 - B10CALL procedure,
- File 9 - B20CALL procedure,
- File 10 - I20RSHL, SHELL programs,
- File 11 - I20RSRT, SHELL programs,
- File 12 - I20TSHL, SHELL programs,
- File 13 - IP2MMSG, dictionary file,
- File 14 - IP2MENU, dictionary file,
- File 15 - IP2HELP, dictionary file,
- File 16 - IP2RSVD, dictionary file,
- File 17 - I20UMNU, dictionary file,
- File 18 - I20RLIB, run time library routine,
- File 19 - HEADING, run time library routine,
- File 20 - I23RLIB, run time library routine,
- File 21 - ICRMFIL, run time library routine,
- File 22 - IP20ABS, absolute code for IPF2,
- File 23 - I20CBL, run time copy library,
- File 24 - QADICT1, dictionary structure files,
- File 25 - QADICT2, dictionary structure files,
- File 26 - QADICT3, dictionary structure files,
- File 27 - QADICT4, dictionary structure files,
- File 28 - MENCMD, menu file,
- File 29 - VERIPH2, verification procedure for IPF2,
- File 30 - VERIPH3, verification command file for procedure VERIPH2,
- File 31 - IPF2OUT, verification output file for procedure VERIPH2, and
- Files 32 - BUSALES, sales data base backup. through 63

INSTALLATION PROCEDURE

Install IPF2 under the user name APPLLIB by entering the following commands at the system console after mounting REL76.

```
X.DIS.  
SUI,377774.  
LABEL,IP2TAPE,D= { HY }  
                  { HD } ,L=IPF2V23,VSN=REL76.  
                  { PE }  
COPYYBF,IP2TAPE,IPF2REL.  
SAVE,IPF2REL.  
BEGIN,IP2LOAD,IPF2REL,TOUSE=APPLLIB,  
FRM=APPLLIB.
```

INSTALLATION VERIFICATION

Under any user name, enter the following commands to verify the installation of IPF2.

```
GET,VERIPF2/UN=APLLIB.  
BEGIN,VERIPF2.
```

The verification procedure:

1. Reloads the SALES database.
2. Defines new files for the SALES database.
3. Verifies the IPF2 program.

If the verification procedure is done interactively, you will notice a considerable pause between steps 1 and 2. This is normal.

Compare the output from the verification procedure with the output in file IPF2OUT. They should be identical except that:

- The dates on the reports will differ.
- The verification procedure output will have additional blank lines where an end-of-record occurs. These blank lines were eliminated in file IPF2OUT.

If the verification output and file IPF2OUT are not identical (except for the preceding two exceptions), reinstall IPF2.

To get a listing of IPF2OUT, enter the following commands.

```
ATTACH,IPF2OUT/UN=APLLIB.  
COPYBF,IPF2OUT,OUTPUT.
```

PDS/MAGEN PRODUCTS

PDS/MAGEN V1.3B5

RELEASE DESCRIPTION

PDS/MaGen runs under NOS 2 to provide the user with matrix generating and report writing capabilities for use in conjunction with APEX-III and/or APEX-IV. PDS/MaGen is designed to execute from permanent files.

Hardware Requirements

PDS/MaGen requires the same minimum hardware configuration as NOS 2. A minimum field length of 70K octal is required for installation.

Deficiencies

None.

Release Materials

PDS/MaGen resides on the tape known as REL65A. It has the following characteristics: 7-track with 800 characters per inch (cpi) or 9-track with either 800 or 1600 cpi, binary recording mode, PDSMAGENV1P3B5 as file ID in HDR1 label, and six files.

- File 1 - installation deck,
- File 2 - absolute binaries of PDS/MaGen,
- File 3 - empty,
- File 4 - empty,
- File 5 - verification deck, and
- File 6 - sample output from verification run.

Listings of the installation deck and the verification deck may be obtained by executing the following job:

```
LIST,T50.  
USER. (Supply valid USER card.)  
LABEL(TAPE,R,L=PDSMAGENV1P3B5,D= { HY },  
VSN = REL65A) { HD },  
COPYSBF,TAPE. { PE },  
SKIPF(TAPE,4)  
COPYSBF,TAPE.  
7/8/9  
6/7/8/9
```

Installation Parameters

None.

INSTALLATION PROCEDURE

PDS/MaGen is installed by executing the first file of REL65A. This deck reads the PDS/MaGen system from REL65A, and installs an executable file of the PDS/MaGen system on a permanent file name PDS/UN=APPLLIB.

To begin the installation procedure, the following commands must be entered at the system console:

```
X.DIS.  
SUI,377774.  
LABEL,TAPE,R,L=PDSMAGENV1P3B5,D= { HY },  
VSN=REL65A. { HD },  
COPYSBF,TAPE,INSTALL. { PE },  
BEGIN,,INSTALL.
```

INSTALLATION VERIFICATION

The following job may be used to verify installation of PDS/MaGen:

```
VER,T50.  
USER. (Supply valid USER card.)  
LABEL(TAPE,R,L=PDSMAGENV1P3B5,D= { HY },  
VSN=REL65A) { HD },  
SKIPF(TAPE,4) { PE },  
ATTACH,PDS/UN=APPLLIB,M=E.  
RFL,100000.  
REDUCE(-)  
PDS,I=TAPE.  
6/7/8/9
```

File 6 of REL65A can be copied to OUTPUT and used to validate correct execution of the verification run.

PERT/TIME PRODUCTS

PERT/TIME V2.1

RELEASE DESCRIPTION

PERT/TIME V2.1 is a program used to plan, monitor and evaluate projects.

Hardware Requirements

PERT/TIME V2.1 requires up to three tape units and 65K central memory to run.

Release Materials

REL52B contains PERT/TIME V2.1 release materials and has the following characteristics: labeled, 7-track with 800 characters per inch (cpi) or 9-track with either 800 or 1600 cpi, binary recording mode, FI=PERT2P1, and six files:

- File 1 - installation procedure,
- File 2 - absolute binaries of PERT-TIME V2.1,
- File 3 - empty,
- File 4 - empty,
- File 5 - verification deck, and
- File 6 - sample output from verification run.

INSTALLATION PROCEDURE

PERT/TIME V2.1 is installed under user number APPLLIB by entering the following commands at the system console after mounting REL52B.

```
X.DIS.  
SUI,377774.  
LABEL,TAPE,FI=PERT2P1,D= { HY }  
                          { HD },VSN=REL52B.  
                          { PE }  
  
COPYBF,TAPE,INSTALL.  
BEGIN,,INSTALL.
```

INSTALLATION VERIFICATION

The following job may be used to verify installation of PERT/TIME V2.1:

```
VERIFY,T50.  
USER. (Supply valid USER  
CHARGE. and CHARGE cards.)  
  
LABEL,TAPE,FI=PERT2P1,D= { HY }  
                          { HD },VSN=REL52B.  
                          { PE }  
  
SKIPF,TAPE,4.  
UPDATE,F,P=TAPE,R=C,*==,D,8.  
ROUTE(COMPILE,DC=IN)  
7/8/9  
=IDENT,PERTV  
=D,VERIFY.3  
USER. (Supply valid USER  
CHARGE. and CHARGE cards.)  
=C,VERIFY  
6/7/8/9
```

SIMSCRIPT II.5 PRODUCTS

SIMSCRIPT II.5 V4.6

RELEASE DESCRIPTION

SIMSCRIPT II.5 V4.6 runs under NOS 2 and is designed to execute from permanent files.

Hardware Requirements

The SIMSCRIPT II.5 system requires the same minimum hardware configuration as NOS 2. The compiler requires a minimum 60K octal field length; however, core requirements for compilation are dynamic and dependent on source program length. A 70K octal field length is sufficient for most programs.

Deficiencies

None.

Release Materials

SIMSCRIPT II.5 is contained on the tape known as REL64A. REL64A has the following characteristics: 7-track with 800 characters per inch (cpi) or 9-track with either 800 or 1600 cpi, binary recording mode, SIMII5V4P51 as file ID in the HDR1 label, and eight files.

- File 1 - installation/verification decks,
- File 2 - absolute binaries of the SIMSCRIPT II.5 compiler,
- File 3 - relocatable binaries of SIMSCRIPT II.5 execution library in LIBGEN format,
- File 4 - empty,
- File 5 - empty,
- File 6 - sample output from verification run,
- File 7 - compiler error messages, and
- File 8 - execution error messages.

A listing of the installation and verification procedure file may be obtained by running the following job.

```
LIST,T50.
USER,username,password,familyname.
CHARGE,*
LABEL,TAPE,R,L=SIMII5V4P6,D= { HY
                                HD },
                                PE }
VSN=REL64A.
COPYSBF,TAPE,OUTPUT.
--eoi--
```

INSTALLATION AND VERIFICATION PROCEDURE

The installation procedure file on file 1 of REL64A installs the SIMSCRIPT II.5 binaries on four permanent files:

SIMII5 -	SIMSCRIPT II.5 compiler,
SIM2LIB -	SIMSCRIPT II.5 execution library,
SIMERRC -	SIMSCRIPT II.5 compiler error message file, and
SIMERRE -	SIMSCRIPT II.5 execution library error message file.

SIMII5 and SIM2LIB are direct access files. SIMERRC and SIMERRE are indirect access files. SIMII5 is installed as an execute only file.

The error message files must be SAVED under user name APPLLIB because the SIMSCRIPT II.5 compiler or a running SIMSCRIPT II.5 program will attempt to GET these files internally from user name APPLLIB. If the error message files do not exist, or are on a different user name, an error number is printed in the job dayfile, but no error message is printed.

To install and verify SIMSCRIPT II.5, the following job must be run from the system console:

```
X.DIS.
SUI,377774.
LABEL,TAPE,L=SIMII5V4P6,D= { HY
                            HD },
                            PE }
VSN=REL64A.
COPYBF,TAPE,INSTALL.
BEGIN,,INSTALL.
```

Notes and Cautions

Permanent Files

The installation procedures file on file 1 of REL64A does not check for existing permanent files with the names SIMII5, SIM2LIB, SIMERRC, or SIMERRE. If files already exist under these names, they must either be purged or renamed.

Execute Only Files

SIMII5 is installed as a direct access execute only file. The following control card is required to attach it.

```
ATTACH,SIMII5/UN=APPLLIB,M=E.
```

TIGS 1 PRODUCT OPTIONS

TIGS 1 OVERVIEW

RELEASE DESCRIPTION

TIGS 1 (Terminal Independent Graphics System Version 1) runs under NOS 2 and the IAF communications subsystem. TIGS provides the user with an interactive graphic capability.

TIGS 1 consists of a preprocessor and a postprocessor. The preprocessor handles all device-independent functions. The postprocessor handles all device-dependent functions. Three levels of TIGS are available (LEVEL 1, LEVEL 2, and LEVEL 3). LEVEL 1 provides a subset of the capabilities of LEVEL 2; LEVEL 2 provides a subset of the capabilities of LEVEL 3. The levels are upward compatible.

The operation of TIGS 1 under NOS requires the installation of NAM, IAF, and the associated products.

HARDWARE CONFIGURATION

The minimum hardware configuration required for NOS 2 and IAF is required to support TIGS 1.

RELEASE MATERIALS

The TIGS 1 release requires both the preprocessor magnetic tape, REL62A, and an appropriate postprocessor tape. See the individual postprocessor sections for installation, terminal operation, and verification of TIGS 1.

TIGS 1 PREPROCESSOR

The TIGS 1 preprocessor resides on the tape with a vsn of REL62A. REL62A has the following characteristics: 7-track with 800 characters per inch (cpi) or 9-track with either 800 or 1600 cpi, binary recording mode, TIGSPRE as the file ID in the HDR1 label, and six files.

- File 1 - empty,
- File 2 - empty,
- File 3 - empty,
- File 4 - TIGS 1 preprocessor source code program library in Update format,

File 5 - empty, and

File 6 - empty.

TEKTRONIX 401X POSTPROCESSOR OPTION

RELEASE MATERIALS

The Tektronix 401X postprocessor runs under NOS 2 when installed with the TIGS 1 preprocessor.

The Tektronix 401X postprocessor resides on the tape with a vsn of REL62B. This tape has the following characteristics: 7-track with 800 cpi or 9-track with either 800 or 1600 cpi, binary recording mode, TIGSTEK401X as the file ID in the HDR1 label, and six files.

- File 1 - installation job program library in Update format,
- File 2 - empty,
- File 3 - empty,
- File 4 - TIGS 1 Tektronix 401X postprocessor source code program library in Update format,
- File 5 - verification program in Update format, and
- File 6 - empty.

NOTES AND CAUTIONS

All limitations applicable to NOS 2 and IAF also apply to TIGS 1 with the Tektronix 401X postprocessor.

All TIGS 1 subroutines are callable from application programs that have been written in FORTRAN Extended 4 or FORTRAN 5.

Communications between the terminal and the central site are supported for TIGS 1 with the Tektronix 401X postprocessor in asynchronous communications mode at line speeds from 300 through 9600 baud.

The installer must be sure that no permanent files exist with the same names as the files generated in the installation procedure. The following permanent files may be generated: TIGVFY, L1T401X, L3T401X, CFGEN, and CFUTIL.

INSTALLATION DESCRIPTION

TIGS Libraries

The installation of TIGS1 with the Tektronix 401X postprocessor allows the user to generate a LEVEL 1 library (L1T401X) and/or a LEVEL 3 library (L3T401X). Each library is a NOS direct access file. Both libraries can be used in a static, overlay, or segment loading environment.

UNIPLLOT Interface

Users who wish to use the TIGS 1 interface to UNIPLLOT/UNIPOST must specify =DEFINE,UNIPLLOT as an Update directive. If the directive is not included in the update, the program logic required to process calls to UNISCR, UNION, and UNIOFF will be absent from the installed library (or libraries) and any such calls will be ignored. If the UNIPLLOT interface is not required, do not install it. The two advantages in not including the interface in the library (or libraries) are: a slightly smaller field length and the elimination of nonfatal loader errors (unsatisfied externals) when the UNIPLLOT library is not declared.

Configuration Defaults

Users may also wish to specify installation defaults for terminal type, baud rate, tablet availability, and hardcopy unit availability. If the same configuration is used repeatedly, specification of the installation defaults will minimize the question/answer session during TIGS 1 initialization. When the installation defaults are to be used, only a single Y response is required during initialization. Installation defaults are specified using =DEFINE Update directives (see step 2 in the Installation Procedure subsection).

Installation Verification

The installation verification program TIGVFY (relocatable binary) is generated by the installation procedure. How to use the installation verification program is described under Verification Procedure later in this section.

Neutral Display File Conversion

All TIGS 1.3 neutral display files must undergo a one-time conversion before they can be used by a TIGS 1.4 application program. The conversion programs are installed by the installation job by specifying =DEFINE,NDFCONV as an Update directive. The conversion programs consist of two binary files: (CFGEN and CFUTIL). The conversion programs are created as direct access permanent files. Instructions for running these programs are described in the Running the NDF Conversion Programs subsection and in the Converting from Previous Versions of TIGS appendix of the TIGS 1.4 Reference Manual.

INSTALLATION PROCEDURE

The procedure for installing TIGS 1 with the Tektronix 401X postprocessor is outlined in the following three steps.

Step 1

This step generates Update listings of the installation job and the verification program.

The installation job is file 1 on the Tektronix 401X postprocessor release tape (REL62B). File 1 is a program library in Update format with = (equals) as the master control character. The verification program is file 5. File 5 is a program library in Update format with * (asterisk) as the master control character.

Perform an update run against file 1 of REL62B to obtain the sequence number that corresponds to any commands that must be modified for installation. An L=7 listing of the installation job and verification program can be obtained by executing the following job.

```
LISTI,T10,CM65000.
USER,username,password,familyname.
CHARGE,*
LABEL,TIGSPL,R,L=TIGSTEK401X,VSN=REL62B,F=I,
D= { HY } .           (7-track, 800 cpi)
   { HD } .           (9-track, 800 cpi)
   { PE } .           (9-track, 1600 cpi)
COP YBF,TIGSPL,OLDPLT.
SKIPF,TIGSPL,3.
COP YBF,TIGSPL,OLDPLV.
UNLOAD,TIGSPL.
UPDATE,F,P=OLDPLT,C=0,L=7,*=,U.
UPDATE,F,P=OLDPLV,C=0,L=7,U.
--eoi--
```

Step 2

This step installs a desired combination of the following files. These files are installed as direct access permanent files with a file access category of semi-private.

- A LEVEL 1 library.
- A LEVEL 3 library.
- A verification program (relocatable binary).
- Two neutral display file conversion programs (relocatable binaries).

The job EXTRACT (described in this step) performs a full update on file 1 of the Tektronix 401X postprocessor release tape (REL62B). It modifies the installation job program library with the appropriate accounting information and the DEFINE Update directives required for installation. It then routes the resulting installation job to the NOS input queue.

NOTE

Only the Tektronix 401X postprocessor release tape (REL62B) is required for the EXTRACT job, but both the Tektronix 401X postprocessor release tape (REL62B) and the TIGS 1 preprocessor release tape (REL62A) are required for the installation job routed to the NOS input queue.

EXTRACT,T10,CM65000.
 USER,username,password,familyname.
 CHARGE,*.
 LABEL,TIGSPL,R,L=TIGSTEK401X,VSN=REL62B,F=I,
 D= { HY (7-track, 800 cpi)
 { HD (9-track, 800 cpi)
 { PE (9-track, 1600 cpi)
 COPYBF,TIGSPL,OLDPL.
 UNLOAD,TIGSPL.
 UPDATE,F,*=,L=17,D,8.
 ROUTE,COMPILE,D=C=IN.
 --eor--
 =IDENT,INSTALL
 =DEFINE, { HY (7-track, 800 cpi)
 { HD (9-track, 800 cpi)
 { PE (9-track, 1600 cpi)
 =DEFINE,LEVEL1 (Builds the LEVEL 1 library.
 Optional directive.)
 =DEFINE,LEVEL3 (Builds the LEVEL 3 library.
 Optional directive.)
 =DEFINE,FTN4 (Enables the generated libraries
 and binaries to run with
 FORTRAN Extended 4. Either
 FTN4 or FTN5 must be defined,
 but not both.)
 =DEFINE,FTN5 (Enables the generated libraries
 and binaries to run with
 FORTRAN 5. Either FTN4 or
 FTN5 must be defined, but not
 both.)
 =DEFINE,UNIPLLOT (Includes the TIGS interface to
 UNIPLLOT in the TIGS libraries.
 If the =DEFINE,UNIPLLOT direc-
 tive is omitted, any application
 program reference to the TIGS
 routines UNISCR, UNION, and
 UNIOFF is ignored.)
 =DEFINE, { A4006 (asynchronous 4006)
 { A4010 (asynchronous 4010)
 { A4014 (asynchronous 4014)
 { A4016 (asynchronous 4016)
 (Specifies the installation
 default terminal type. This
 default may be overridden by
 answering the initialization
 questions individually. If this
 directive is omitted, asynchro-
 nous 4014 with the enhanced
 graphics module becomes the
 default type.)
 =DEFINE, { BAUD300 (Specifies the installation
 { BAUD2400 default baud rate. This
 { BAUD4800 default may be overridden by
 { BAUD9600 answering the initialization
 questions individually. If this
 directive is omitted, 1200 baud
 becomes the default.)
 =DEFINE,TABLET (Specifies a tablet is available.
 This default may be overridden
 by answering the initialization
 questions individually. If this
 directive is omitted, no tablet
 is defined.)

=DEFINE,HARDCOPY (Specifies a hardcopy device is
 available. This default may be
 overridden by answering the
 initialization questions individ-
 ually. If this directive is
 omitted, no hardcopy device is
 defined.)

=DEFINE,NDFCONV (Installs the neutral display file
 conversion programs. Two
 binaries (CFGEN and CFUTIL)
 are installed. This directive is
 required if neutral display files
 will be converted from version
 1.3 to version 1.4.)

=D,TIGS1.3 (Modifies the installation job
 program library with appropri-
 ate accounting information.
 The dummy USER command
 sequence number 3 was
 obtained from the COMPILE
 file listing resulting from step 1
 in the Installation Procedure
 subsection.)

--eoi--

Step 3

This step is optional. It puts a copy of the LEVEL 1 and/or LEVEL 3 TIGS library under the user name LIBRARY. The commands must be entered at the system console.

If a LEVEL 1 library (L1T401X) was built, enter the following commands to put it under the user name LIBRARY.

```

ATTACH,A=L1T401X.
SUI,377776.
DEFINE,B=L1T401X/CT=PU.
COPY,A,B,V.
  
```

If a LEVEL 3 library was built, enter the following commands to put it under the user name LIBRARY.

```

ATTACH,C=L3T401X.
SUI,377776.
DEFINE,D=L3T401X/CT=PU.
COPY,C,D,V.
  
```

TERMINAL SET UP PROCEDURES

The terminal that will be used for the verification of the TIGS installation must be set up. Instructions for setting up the 4006, 4010, 4014, and 4016, Tektronix terminals follow.

Tektronix 4006 Terminal

Complete the following to set up the Tektronix 4006 terminal.

1. Turn the terminal power on by turning the POWER switch, located at the rear of the display unit, to the ON position.
2. Allow the terminal to warm up.

3. Press the PAGE key to erase the screen and to position the cursor to home position (the upper left-hand corner of the screen).
4. Select the appropriate transmit and receive baud rates using the baud rate dials located at the rear of the display unit.
5. Set the FULL/HALF DUPLEX switch located at the rear of the display unit. The setting of the switch is NOS installation dependent.

8. Place the terminal in local mode. Press and keep depressed the SHIFT key. While the SHIFT key is depressed, press the PAGE/RESET key. Then press and keep depressed both the SHIFT and CNTL keys. While both the SHIFT and CNTL keys are pressed, press the P key. Place the terminal in line mode. The terminal is now operational.

Tektronix 4010/4014/4016 Terminals

Complete the following to set up the Tektronix 4010, 4014, and 4016 asynchronous terminals.

1. Turn the terminal power on.
 - Tektronix 4010 terminal: The POWER switch is located beneath the keyboard at the top of the pedestal stand. The red POWER indicator, located at the top of the keyboard, will illuminate when power has been applied to the terminal.
 - Tektronix 4014 or 4016 terminal: The POWER switch is located on the front lower right-hand corner of the pedestal stand. The green POWER indicator, located on the upper left-hand corner of the keyboard, will illuminate when power has been applied to the terminal.
2. Allow the terminal to warm up.
3. Press the PAGE key to erase the screen and to position the cursor to home position (the upper left-hand corner of the screen).
4. Set the ASCII/ALT switch to the ASCII position.
5. Select the appropriate baud rate dial settings. The terminal baud rate dial settings correspond to the baud rate in use.
 - Tektronix 4010 terminal: Select the appropriate transmit and receive baud rates using the baud rate dials located at the rear of the pedestal stand.
 - Tektronix 4014 or 4016 terminal: Select the appropriate baud rate using the baud rate dial located at the rear of the pedestal stand.
6. Set the FULL/HALF DUPLEX switch; it is NOS installation dependent.

If the Tektronix 4010 or 4014 terminal does not have option 20, the terminal is now operational. If the terminal does have option 20, steps 7 and 8 must be done before the terminal is operational.
7. Set the CODE EXPANDER switch to the OFF position.

VERIFICATION PROCEDURE

To verify the proper installation of TIGS 1, complete the following steps. This process assumes the TIGS libraries do not reside under the user name LIBRARY. The verification program TIGVFY is a permanent file that was defined by the installation job.

1. Log in to NOS with a valid family name, user name, password, and charge number (if required).
2. Go to step 6 if the LEVEL 1 library (L1T401X) was not installed.
3. Attach the verification program and user library by entering the following.

```
ATTACH,TIGVFY.
ATTACH,L1T401X.
```
4. Declare the TIGS user library as a library.

```
LIBRARY,L1T401X.
```
5. Load and execute the verification program.

```
TIGVFY.
```

The terminal operator will be asked if the installation defaults are to be accepted (see figure TIGS-1).† If the installation defaults are correct for terminal type and baud rate, the operator types a Y. The terminal screen is cleared and either Figure TIGS-2 is displayed if the terminal type is from 5 through 9 or Figure TIGS-3 is displayed if the terminal type is 1 or 3. The verification test pauses. Enter (CR) to complete the execution of the verification test. The verification continues with step 6.

If the defaults are not correct, the operator must answer N and the following TIGS prompts and operator responses occur.

TIGS prompt:

```
ENTER TERMINAL TYPE
1 4006 ASYNCHRONOUS
3 4010 ASYNCHRONOUS
5 4014 ASYNCHRONOUS
7 4014 W/EGM ASYNCHRONOUS
9 4016 ASYNCHRONOUS
```

Operator input:

The number that corresponds to the terminal type in use.

† The initialization questions can be overridden by supplying the subroutine ZPIQST(ITERM,IBAUD,ITABL,IHC) to provide the values for each parameter (see the TIGS 1.4 Reference Manual).

TIGS prompt:

ENTER BAUD RATE
(300,1200,2400,4800,9600)

Operator input:

The baud rate that is in use.

TIGS prompt:

IS A TABLET AVAILABLE (Y/N)

Operator input:

N (The tablet is not required for the verification program.)

TIGS prompt:

IS A HARDCOPY UNIT AVAILABLE (Y/N)

Operator input:

N (The verification program does not require the availability of a hardcopy unit.)

Finally, the terminal screen is cleared. Either Figure TIGS-2 is displayed if terminal type 5 through 9 was selected or Figure TIGS-3 is displayed if terminal type 1 or 3 was selected. The verification test pauses. The operator must enter (CR) to complete the execution of the verification test.

PAUSE, ENTER CR TO CONTINUE

INSTALLATION DEFAULT VALUES ARE
7 4014 W/EGM ASYNCHRONOUS
9600 BAUD
TABLET IS NOT AVAILABLE
HARDCOPY UNIT IS AVAILABLE
DO YOU ACCEPT THESE DEFAULTS (Y/N)

Figure TIGS-1. Acceptable Tektronix 401X Defaults

6. Go to step 10 if a LEVEL 3 library (L3T401X) was not installed.
7. Attach the verification program and user library.
ATTACH,TIGVPY.
ATTACH,L3T401X.
8. Declare the TIGS user library as a library.
LIBRARY,L3T401X.
9. Repeat step 5 to verify the LEVEL 3 library (L3T401X) installation.
10. Purge any unnecessary files generated during the installation or verification of TIGS 1.
11. Enter BYE to log off the system.

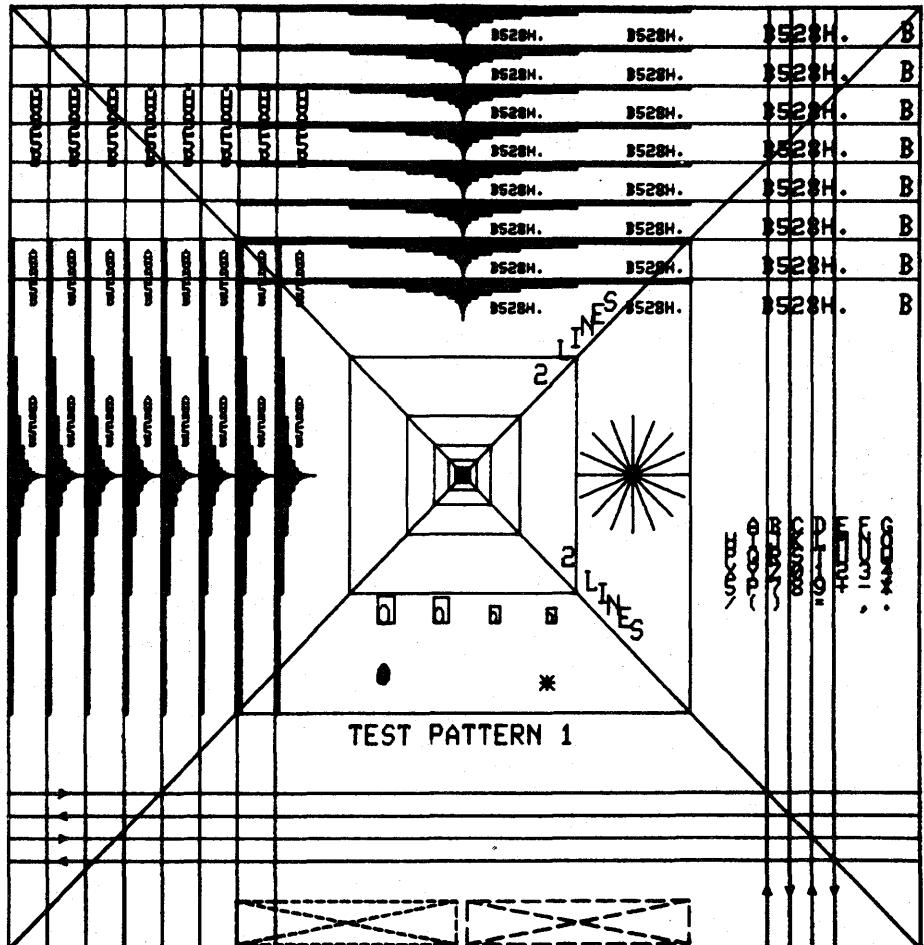

Figure TIGS-2. Figure Displayed on Terminal Types 5 through 9

PAUSE,ENTER OR TO CONTINUE

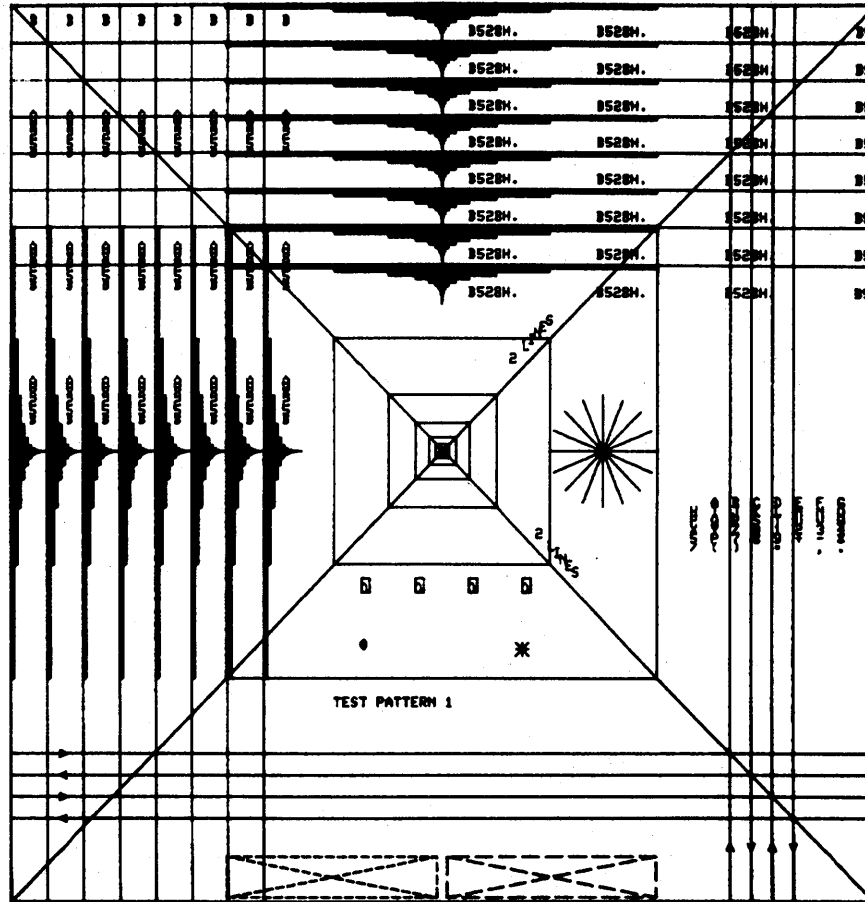

Figure TIGS-3. Figure Displayed on Terminal Types 1 or 3

RUNNING THE NDF CONVERSION PROGRAMS

Any neutral display file (NDF) created under TIGS version 1.3 will need a one-time conversion in order to be used by TIGS version 1.4. The conversion programs must have been installed as part of the TIGS installation procedure in order to do the following job. The job can be run in either batch mode or interactive mode (under the BATCH subsystem).

```

job command.
USER,username,password,familyname.
CHARGE,*
ATTACH,OLDNDF=pfname. (1.3 NDF must be local
                        file OLDNDF.)
ATTACH,OLDLIB=pfname. (Attaches the library
                        under which the old NDF
                        was created.)
LIBRARY,OLDLIB. (Declares OLDLIB as a
                 library.)
ATTACH,CFGEN. (Attaches the old NDF to
               conversion file program.)
CFGEN. (Generates a conversion
        file on TAPE1.)
ATTACH,NEWLIB=pfname. (Attaches TIGS version
                       1.4 library.)
LIBRARY,NEWLIB. (Declares NEWLIB as a
                 library.)
ATTACH,CFUTIL. (Attaches the conversion
                file to version 1.4
                program.)

```

```

DEFINE,NEWNDF=pfname. (Defines version 1.4 NDF
                       as a permanent file.)
CFUTIL. (Generates version 1.4
         NDF on file NEWNDF.)
--eoi--

```

Since the neutral display file is not associated with any one postprocessor, the libraries OLDLIB and NEWLIB may be for any TIGS postprocessor. However, OLDLIB must be a version 1.3 library and NEWLIB must be a version 1.4 library.

CHROMATICS 1599 POSTPROCESSOR OPTION

RELEASE MATERIALS

The Chromatics 1599 postprocessor runs under NOS 2 when installed with the TIGS 1 preprocessor.

The Chromatics 1599 postprocessor resides on the tape with a vsn of REL62E. This tape has the following characteristics: 7-track with 800 cpi or 9-track with either 800 or 1600 cpi, binary recording mode, TIGSCHM1599 as the file ID in HDR1 label, and six files.

- File 1 - installation job program library in Update format,
- File 2 - empty,

- File 3 - empty,
- File 4 - TIGS 1 Chromatics postprocessor source code program library in Update format,
- File 5 - verification program in Update format, and
- File 6 - empty.

NOTES AND CAUTIONS

All limitations applicable to NOS 2 and IAF also apply to TIGS 1 with the Chromatics 1599 postprocessor.

All TIGS 1 subroutines are callable from application programs that have been written in FORTRAN Extended 4 or FORTRAN 5.

Communications between the terminal and the central site are supported for TIGS 1 with the Chromatics 1599 postprocessor in asynchronous communications mode at line speeds from 300 through 9600 baud.

The installer must be sure that no permanent files exist with the same names as the files generated in the installation procedure. The following permanent files may be generated: TIGVFY, L1C1599, L3C1599, CFGEN, and CFUTIL.

INSTALLATION DESCRIPTION

TIGS Libraries

The installation of TIGS 1 with the Chromatics 1599 postprocessor allows the user to generate a LEVEL 1 library (L1C1599) and/or a LEVEL 3 library (L3C1599). Each library is a NOS direct access file. Both libraries can be used in a static, overlay, or segment loading environment.

UNIPLLOT Interface

Users who wish to use the TIGS 1 interface to UNIPLLOT/UNIPOST must specify =DEFINE,UNIPLLOT as an Update directive. If the directive is not included in the update, the program logic required to process calls to UNISCR, UNION, and UNIOFF will be absent from the installed library (or libraries) and any such calls will be ignored. If the UNIPLLOT interface is not required, do not install it. The two advantages in not including the interface in the library (or libraries) are: a slightly smaller field length and the elimination of nonfatal loader errors (unsatisfied externals) when the UNIPLLOT library is not declared.

Configuration Defaults

Users may also wish to specify installation defaults for baud rate and hardcopy unit availability. If the same configuration is used repeatedly, specification of the installation defaults minimizes the question/answer session during TIGS 1 initialization. When the installation defaults are used, only a single Y response is required during initialization. Installation defaults are specified using =DEFINE Update directives (see step 2 in the Installation Procedure subsection).

Installation Verification

The installation verification program TIGVFY (relocatable binary) is generated by the installation procedure. How to use the installation verification program is described under Verification Procedure later in this section.

Neutral Display File Conversion

All TIGS 1.3 neutral display files must undergo a one-time conversion before they can be used by a TIGS 1.4 application program. The conversion programs are installed by the installation job by specifying =DEFINE,NDFCONV as an Update directive. The conversion program consists of two binary files: CFGEN and CFUTIL. The conversion programs are created as direct access permanent files. Instructions for running these programs are described in the Running the NDF Conversion Programs subsection and in the Converting From Previous Versions of TIGS appendix of the TIGS 1.4 Reference Manual.

INSTALLATION PROCEDURE

The procedure for installing TIGS 1 with the Chromatics 1599 postprocessor is outlined in the following three steps.

Step 1

This step generates Update listings of the installation job and the verification program.

The installation job is file 1 on the Chromatics postprocessor release tape (REL62E). File 1 is a program library in Update format with = (equals) as the master control character. The verification program is file 5. File 5 is a program library in Update format with * (asterisk) as the master control character.

Perform an update run against file 1 of REL62E to obtain the sequence number that corresponds to any commands that must be modified for installation. An L=7 listing of the installation job and verification program can be obtained by executing the following job.

```
LISTL,T10,CM65000.
USER,username,password,familyname.
CHARGE,*
LABEL,TIGSPL,R,L=TIGSCHM1599,VS=N=REL62E,F=I,
D= { HY } (7-track, 800 cpi)
   { HD } (9-track, 800 cpi)
   { PE } (9-track, 1600 cpi)
COP YBF,TIGSPL,OLDPLT.
SKIP F,TIGSPL,3.
COP YBF,TIGSPL,OLDPLV.
UNLOAD,TIGSPL.
UPDATE,F,P=OLDPLT,C=0,L=7,*==,U.
UPDA TE,F,P=OLDPLV,C=0,L=7,U.
--eoi--
```

Step 2

This step installs a desired combination of the following files. These files are installed as direct access permanent files with a file access category of semi-private.

- A LEVEL 1 library.
- A LEVEL 3 library.

- A verification program (relocatable binary).
- Two neutral display file conversion programs (relocatable binaries).

The job EXTRACT (described in this step) performs a full update on file 1 of the Chromatics postprocessor release tape (REL62E). It modifies the installation job program library with the appropriate accounting information, and the DEFINE Update directives required for installation. It then routes the resulting installation job to the NOS input queue.

NOTE

Only the Chromatics postprocessor release tape (REL62E) is required for the EXTRACT job, but both the Chromatics postprocessor release tape (REL62E) and the TIGS 1 preprocessor release tape (REL62A) are required for the installation job routed to the NOS input queue.

```

EXTRACT,T10,CM65000.
USER,username,password,familyname.
CHARGE,*
LABEL,TIGSPL,R,L=TIGSCHM1599,VSN=REL62E,F=I,
D= { HY } (7-track, 800 cpi)
   { HD } (9-track, 800 cpi)
   { PE } (9-track, 1600 cpi)
COPYBF,TIGSPL,OLDPL.
UNLOAD,TIGSPL.
UPDATE,F,*=,L=17,D,8.
ROUTE,COMPILE,DC=IN.
--eor--
=IDENT,INSTALL
=DEFINE, { HY } (7-track, 800 cpi)
         { HD } (9-track, 800 cpi)
         { PE } (9-track, 1600 cpi)
=DEFINE,LEVEL1 (Builds the LEVEL 1 library.
                Optional directive.)
=DEFINE,LEVEL3 (Builds the LEVEL 3 library.
                Optional directive.)
=DEFINE,FTN4 (Enables the generated
              libraries and binaries to run
              with FORTRAN Extended 4.
              Either FTN4 or FTN5 must be
              defined, but not both.)
=DEFINE,FTN5 (Enables the generated
              libraries and binaries to run
              with FORTRAN 5. Either
              FTN4 or FTN5 must be
              defined, but not both.)
=DEFINE,UNIPL0T (Includes the TIGS interface to
                 UNIPL0T in the TIGS
                 libraries. If the
                 =DEFINE,UNIPL0T directive
                 is not included, any
                 application program reference
                 to the TIGS routines UNISCR,
                 UNION, and UNIOFF is
                 ignored. Optional directive.)

```

```

=DEFINE, { BAUD300 } (Specifies the installation
                 { BAUD2400 } default baud rate. This
                 { BAUD4800 } default may be overridden by
                 { BAUD9600 } answering the initialization
                                questions individually. If this
                                directive is omitted, 1200
                                baud becomes the default.)

```

```

=DEFINE,HARDCOPY (Specifies a hardcopy device is
                  available. This default may be
                  overridden by answering the
                  initialization questions indi-
                  vidualy. If this directive is
                  omitted, no hardcopy device is
                  defined.)

```

```

=DEFINE,NDFCONV (Installs the neutral display
                  file conversion programs. Two
                  binaries (CFGEN and CFUTL)
                  are installed. This directive is
                  required if neutral display
                  files will be converted from
                  version 1.3 to version 1.4.)

```

```

=D,TIGS1.3 (Modifies the installation job
             program library with appropriate
             accounting information. The dummy
             USER command sequence number 3
             was obtained from the COMPILE
             file listing resulting from step
             1 in the Installation Procedure
             subsection.)

```

--eoi--

Step 3

This step is optional. It puts a copy of the LEVEL 1 and/or LEVEL 3 TIGS library under the user name LIBRARY. The commands must be entered at the system console.

If a LEVEL 1 library (L1C1599) was built, enter the following commands to put it under the user name LIBRARY.

```

ATTACH,A=L1C1599.
SUI,377776.
DEFINE,B=L1C1599/CT=PU.
COPY,A,B,V.

```

If a LEVEL 3 library (L3C1599) was built, enter the following commands to put it under the user name LIBRARY.

```

ATTACH,C=L3C1599.
SUI,377776.
DEFINE,D=L3C1599/CT=PU.
COPY,C,D,V.

```

TERMINAL SET UP PROCEDURES

The Chromatics 1599 terminal must be set up so that the installation of TIGS can be verified. Complete the following steps to set up the terminal.

1. Turn the terminal power on by depressing the POWER switch, located at the front of the display unit.
2. Allow the terminal to warm up.
3. Press the RESET key followed by the BOOT key. This bootstraps the terminal software.
4. Press the ESC (escape) key and type in the baud rate selection. The baud rate selections are presented in the following list.

<u>Entry</u>	<u>Resulting Rate</u>
RO4	300 baud
RO7	1200 baud
RO9	2400 baud
ROB	4800 baud
ROC	9600 baud

5. Press the ESC (escape) key and type an H. This selects half duplex communications.

VERIFICATION PROCEDURE

To verify the proper installation of TIGS 1, complete the following steps. This process assumes the TIGS libraries do not reside under the user name LIBRARY. The verification program TIGVFY is a permanent file that was defined by the installation job.

1. Log in to NOS with a valid family name, user name, password, and charge number (if required).
2. Go to step 6, if a LEVEL 1 library (L1C1599) was not installed.
3. Attach the verification program and user library.

```
ATTACH,TIGVFY.  
ATTACH,L1C1599.
```

4. Declare the TIGS user library as a library.

```
LIBRARY,L1C1599.
```

5. Load and execute the verification program.

```
TIGVFY.
```

The terminal operator will be asked if the installation defaults are to be accepted (see figure TIGS-4).† If the installation defaults are correct for terminal type and baud rate, the

operator types a Y. The terminal screen is cleared and Figure TIGS-5 is displayed. The verification test pauses. Enter (CR) to complete the execution of the verification test. The verification continues with step 6.

If the defaults are not correct, the operator must answer N and the following TIGS prompts and operator responses occur.

TIGS prompt:

```
ENTER BAUD RATE  
(300,1200,2400,4800,9600)
```

Operator input:

The baud rate that is in use.

TIGS prompt:

```
IS A HARDCOPY UNIT AVAILABLE (Y/N)
```

Operator input:

```
N (The verification program does not require  
the availability of a hardcopy unit.)
```

Finally, the terminal screen is cleared and Figure TIGS-5 is displayed. The verification test pauses. The operator must enter (CR) to complete the execution of the verification test.

6. Go to step 10, if a LEVEL 3 library (L3C1599) was not installed.
7. Attach the verification program and user library.

```
ATTACH,TIGVFY.  
ATTACH,L3C1599.
```
8. Declare the TIGS user library as a library.

```
LIBRARY,L3C1599.
```
9. Repeat step 5 to verify the LEVEL 3 library (L3C1599).
10. Purge any unnecessary files generated during the installation or verification of TIGS 1.
11. Enter BYE to log off the system.

```
INSTALLATION DEFAULT VALUES ARE  
1200 BAUD  
NO HARD COPY AVAILABLE  
DO YOU ACCEPT THESE DEFAULTS (Y/N)
```

Figure TIGS-4. Acceptable Chromatics Defaults

† The initialization questions can be overridden by supplying the subroutine ZPIQST(IBAUD,IHC) to provide the values for each parameter (see TIGS 1.4 Reference Manual).

PAUSE, ENTER OR TO CONTINUE

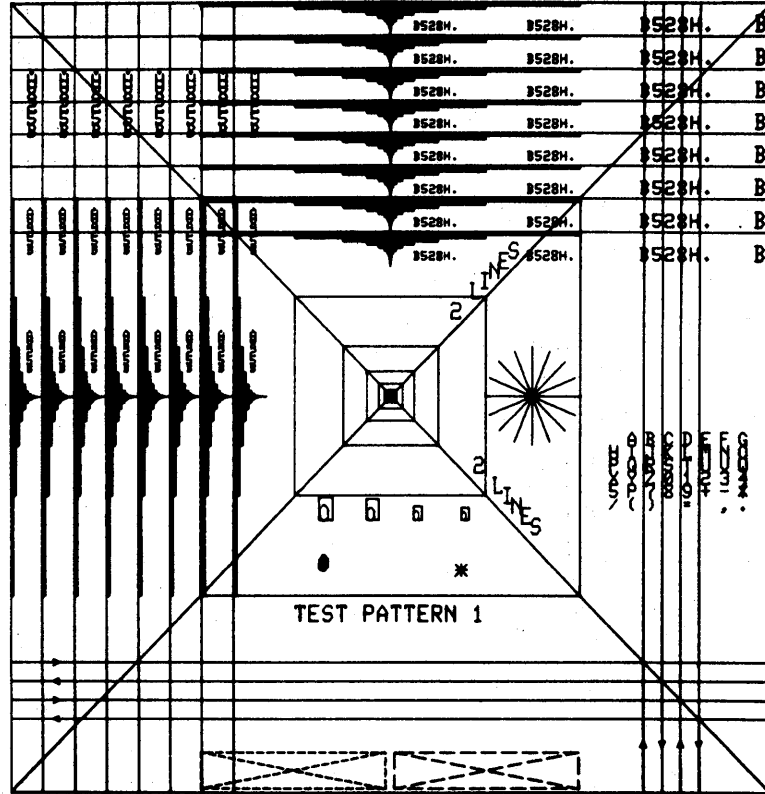

Figure TIGS-5. Figure Displayed on Chromatics 1599

RUNNING THE NDF CONVERSION PROGRAMS

Any neutral display file (NDF) created under TIGS version 1.3 will need to undergo a one-time conversion in order to be used by TIGS version 1.4. The conversion program must have been installed as part of the TIGS installation procedure in order to do the following job. The job can be run in either batch mode or interactive mode (under the BATCH subsystem).

- job command.
- USER,username,password,familyname.
- CHARGE,*.
- ATTACH,OLDNDF=pfname. (1.3 NDF must be local file OLDNDF.)
- ATTACH,OLDLIB=pfname. (Attaches the library under which the old NDF was created.)
- LIBRARY,OLDLIB. (Declares OLDLIB as a library.)
- ATTACH,CFGEN. (Attaches the old NDF to conversion file program.)
- CFGEN. (Generates a conversion file on TAPE1.)
- ATTACH,NEWLIB=pfname. (Attaches TIGS version 1.4 library.)
- LIBRARY,NEWLIB. (Declares NEWLIB as a library.)
- ATTACH,CFUTIL. (Attaches the conversion file to version 1.4 program.)
- DEFINE,NEWNDF=pfname. (Defines version 1.4 NDF as a permanent file.)

CFUTIL.

(Generates version 1.4 NDF on file NEWNDF.)

--eoi--

Since the neutral display file is not associated with any one postprocessor, the libraries OLDLIB and NEWLIB may be for any TIGS postprocessor. However, OLDLIB must be a version 1.3 library, and NEWLIB must be a version 1.4 library.

TEKTRONIX 4114 POSTPROCESSOR OPTION

RELEASE MATERIALS

The Tektronix 4114 postprocessor runs under NOS 2 when installed with the TIGS 1 preprocessor.

The Tektronix 4114 postprocessor resides on the tape with a vsn of REL62F. This tape has the following characteristics: 7-track with 800 cpi or 9-track with either 800 or 1600 cpi, binary recording mode, TIGSTEK4114 as the file ID in HDR1 label, and six files.

- File 1 - installation job program library in Update format,
- File 2 - empty,
- File 3 - empty,
- File 4 - TIGS 1 Tektronix 4114 postprocessor source code program library in Update format,

File 5 - verification program in Update format and,

File 6 - empty.

NOTES AND CAUTIONS

All limitations applicable to NOS 2 and IAF also apply to TIGS 1 with the Tektronix 4114 postprocessor.

All TIGS 1 subroutines are callable from application programs that have been written in FORTRAN Extended 4 or FORTRAN 5.

Communications between the terminal and the central site are supported for TIGS 1 with the Tektronix 4114 postprocessor in asynchronous communications mode at line speeds from 300 to through 9600 baud.

The installer must be sure that no permanent files exist with the same names as the files generated in the installation procedure. The following permanent files may be generated: TIGVfy, L2T4114, L3T4114, CFGEN, and CFUTIL.

INSTALLATION DESCRIPTION

TIGS Libraries

The installation of TIGS 1 with the Tektronix 4114 postprocessor allows the user to generate a LEVEL 2 library (L2T4114) and/or a LEVEL 3 library (L3T4114). Each library is a NOS direct access file. Both libraries can be used in a static, overlay, or segment loading environment.

UNIPLLOT Interface

Users who wish to use the TIGS 1.4 interface to UNIPLLOT/UNIPOST must specify =DEFINE,UNIPLLOT as an Update directive. If the directive is not included in the update, the program logic required to process calls to UNISCR, UNION, and UNIOFF will be absent from the installed library (or libraries) and any such calls will be ignored. If the UNIPLLOT interface is not required, do not install it. The two advantages in not including the interface in the library (or libraries) are: a slightly smaller field length and the elimination of nonfatal loader errors (unsatisfied externals) when the UNIPLLOT library is not declared.

Installation Verification

The installation verification program TIGVfy (relocatable binary) is generated by the installation procedure. How to use the installation verification program is described under Verification Procedure later in this section.

Neutral Display File Conversion

All TIGS 1.3 neutral display files must undergo a one-time conversion before they can be used by a TIGS 1.4 application program. The conversion programs are installed by the installation job by specifying =DEFINE,NDFCONV as an Update directive. The conversion programs consist

of two binary files (CFGEN and CFUTIL). The conversion programs are created as direct access permanent files. Instructions on running these programs are described in the Running the NDF Conversion Programs subsection and in the Converting From Previous Versions of TIGS appendix of the TIGS 1.4 Reference Manual.

INSTALLATION PROCEDURE

The procedure for installing TIGS 1 with the Tektronix 4114 postprocessor is outlined in the following three steps.

Step 1

This step generates Update listings of the installation job and the verification program.

The installation job is on file 1 of the Tektronix 4114 postprocessor release tape (REL62F). File 1 is a program library in Update format with = (equals) as the master control character. File 5 is the verification program. It is a program library in Update format with * (asterisk) as the master control character.

Perform an update run against file 1 of REL62F to obtain the sequence number that corresponds to any commands that must be modified for installation. An L=7 listing of the installation job and verification program can be obtained by executing the following job.

```
LIST,T10,CM65000.
USER,username,password,familyname.
CHARGE,*
LABEL,TIGSPL,R,L=TIGSTEK4114, VSN=REL62F,F=L,
D= { HY } (7-track, 800 cpi)
    { HD } (9-track, 800 cpi)
    { PE } (9-track, 1600 cpi)
COPYBF,TIGSPL,OLDPLT.
SKIPF,TIGSPL,3.
COPYBF,TIGSPL,OLDPLV.
UNLOAD,TIGSPL.
UPDATE,F,P=OLDPLT,C=0,L=7,*==,U.
UPDATE,F,P=OLDPLV,C=0,L=7,U.
--eoi--
```

Step 2

This step installs a desired combination of the following files. These files are installed as direct access permanent files with a file access category of semi-private.

- A LEVEL 2 library.
- A LEVEL 3 library.
- A verification program (relocatable binary).
- Two neutral display file conversion programs (relocatable binaries).

The job named EXTRACT (described in this step), performs a full update on file 1 of the Tektronix 4114 postprocessor release tape (REL62F). It modifies the installation job program library with the appropriate accounting information and with the DEFINE Update directives. It then routes the resulting installation job to the NOS input queue.

NOTE

Only the Tektronix 4114 postprocessor release tape (REL62F) is required for the EXTRACT job, but both the Tektronix 4114 postprocessor release tape (REL62F) and the TIGS 1 preprocessor release tape (REL62A) are required for the installation job routed to the NOS input queue.

```

EXTRACT,T10,CM65000.
USER,username,password,familyname.
CHARGE,*
LABEL,TIGSPL,R,L=TIGSTEK4114,VSN=REL62F,F=I,
D= { HY } (7-track, 800 cpi)
   { HD } (9-track, 800 cpi)
   { PE } (9-track, 1600 cpi)
COPYBF,TIGSPL,OLDPL.
UNLOAD,TIGSPL.
UPDATE,F,*=,L=17,D,8.
ROUTE,COMPILE,DC=IN.
--eor--
=IDENT,INSTALL
=DEFINE, { HY } (7-track, 800 cpi)
         { HD } (9-track, 800 cpi)
         { PE } (9-track, 1600 cpi)
=DEFINE,LEVEL2 (Builds the LEVEL 2 library.
                Optional directive.)
=DEFINE,LEVEL3 (Builds the LEVEL 3 library.
                Optional directive.)
=DEFINE,FTN4 (Enables the generated
              libraries and binaries to run
              with FORTRAN Extended 4.
              Either FTN4 or FTN5 must
              be defined, but not both.)
=DEFINE,FTN5 (Enables the generated
              libraries and binaries to run
              with FORTRAN 5. Either
              FTN4 or FTN5 must be
              defined, but not both.)
=DEFINE,HANDSHAKE (If the user's system does
                  not have flow control
                  (X-ON/X-OFF) and the user
                  is concerned about the
                  possible overflow of the
                  terminal's input queue, include
                  the =DEFINE,HANDSHAKE
                  directive. A terminal's
                  input queue is more likely to
                  overflow for high
                  transmission rates to the
                  terminal than for low
                  transmission rates. If this
                  directive is omitted, TIGS
                  assumes that flow control is
                  available. If queue overflow
                  does occur and HAND-
                  SHAKE is not defined, data
                  sent from the host is lost.
                  This directive affects all
                  libraries being built.)

```

=DEFINE,UNIPILOT

(Includes the TIGS interface to UNIPILOT in the TIGS libraries. If the =DEFINE,UNIPILOT directive is omitted, any application program reference to the TIGS routines UNISCR, UNION and UNIOFF is ignored.)

=DEFINE,NDFCONV

(Installs the neutral display file conversion programs. Two binaries (CFGEN and CFUTIL) are installed. This directive is required if neutral display files will be converted from version 1.3 to version 1.4.)

=D,TIGS1.3

(Modifies the installation job program library with appropriate accounting information. The dummy USER command sequence number 3 was obtained from the COMPILE file listing resulting from step 1 in the Installation Procedure subsection.)

--eoi--

Step 3

This step is optional. It puts a copy of the LEVEL 2 and/or LEVEL 3 TIGS library under the user name LIBRARY. The commands must be entered at the system console.

If a LEVEL 2 library (L2T4114) was built, enter the following commands to put it under user name LIBRARY.

```

ATTACH,A=L2T4114.
SUL,377776.
DEFINE,B=L2T4114/CT=PU.
COPY,A,B,V.

```

If a LEVEL 3 library (L3T4114) was built, enter the following commands to put it under user name LIBRARY.

```

ATTACH,C=L3T4114.
SUL,377776.
DEFINE,D=L3T4114/CT=PU.
COPY,C,D,V.

```

TERMINAL SET UP PROCEDURES

The Tektronix 4114 terminal must be set up so that the installation of TIGS can be verified. Complete the following steps to set up the terminal.

1. Turn the terminal power on by pushing the POWER button, which is located above the keyboard on the base pedestal.
2. Allow the terminal to initialize (some keys on the keyboard remain lit until the terminal has completed its initialization).
3. Press the SET UP key so that the terminal operating modes can be changed at the keyboard. An asterisk (*) should appear to the left of the cursor.

4. Select the appropriate baud rate by entering:
 BAUD number
 number is the desired baud rate. It can range from 300 through 9600.
5. Enter STA BAUD to verify the baud rate entry.
6. Press the SET UP key to complete the process.

VERIFICATION PROCEDURE

To verify the proper installation of TIGS 1, complete the following steps. The following verification process assumes the TIGS libraries do not reside under the user name LIBRARY. The verification program TIGVFY is a permanent file that was defined by the installation job.

1. Log in to NOS with a valid family name, user name, password, and charge number (if required).
2. Go to step 7 if the LEVEL 2 library (L2T4114) was not installed.
3. Attach the verification program and user library.

ATTACH,TIGVFY.
 ATTACH,L2T4114.

4. Declare the TIGS user library as a library.
 LIBRARY,L2T4114.
5. Load and execute the verification program.
 TIGVFY.

As the program begins execution, the keyboard lights will flash, then the screen will clear, and finally the figure (see Figure TIGS-6) is displayed.

The verification test pauses.

6. Enter (CR) to complete the execution of the verification test.
7. Go to step 11 if a LEVEL 3 library (L3T4114) was not installed.
8. Attach the verification program and user library.
 ATTACH,TIGVFY.
 ATTACH,L3T4114.
9. Declare the TIGS user library as a library.
 LIBRARY,L3T4114.
10. Repeat steps 5 and 6 to verify the LEVEL 3 library (L3T4114) installation.
11. Purge all unnecessary files generated during the installation or verification of TIGS 1.
12. Enter BYE to log off the system.

PAUSE, ENTER CR TO CONTINUE

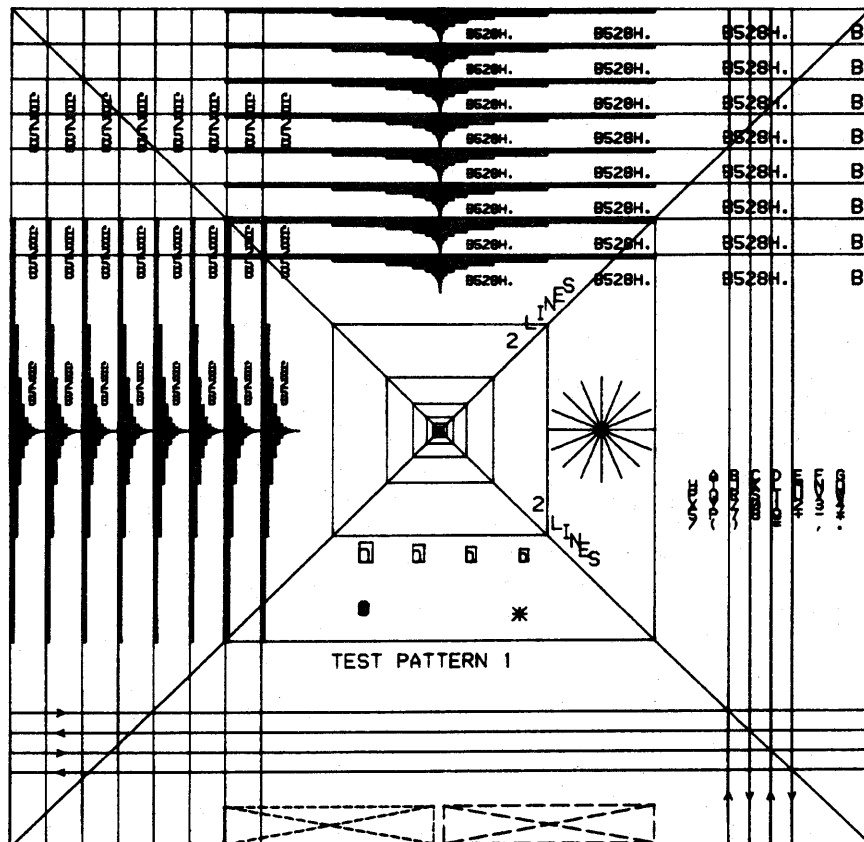

Figure TIGS-6. Figure Displayed on Tektronix 4114

RUNNING THE NDF CONVERSION PROGRAMS

Any neutral display file (NDF) created under TIGS version 1.3 will need to undergo a one-time conversion in order to be used by TIGS version 1.4. The conversion programs must have been installed as part of the TIGS installation procedure in order to do the following job. The job can be run in either batch mode or interactive mode (under the BATCH subsystem).

job command.

USER,username,password,familyname.

CHARGE,*.

ATTACH,OLDNDF=pfname. (1.3 NDF must be a local file named OLDNDF.)

ATTACH,OLDLIB=pfname. (Attaches the library under which the old NDF was created.)

LIBRARY,OLDLIB. (Declares OLDLIB as a library.)

ATTACH,CFGEN. (Attaches the old NDF to conversion file program.)

CFGEN.

(Generates a conversion file on TAPE1.)

ATTACH,NEWLIB=pfname.

(Attaches TIGS version 1.4 library.)

LIBRARY,NEWLIB.

(Declares NEWLIB as a library.)

ATTACH,CFUTIL.

(Attaches the conversion file to version 1.4 program.)

DEFINE,NEWNDF=pfname.

(Defines version 1.4 NDF as a permanent file.)

CFUTIL.

(Generates version 1.4 NDF on file NEWNDF.)

--eoi--

Since the neutral display file is not associated with any one postprocessor, the libraries OLDLIB and NEWLIB may be for any TIGS postprocessor. However, OLDLIB must be a version 1.3 library and NEWLIB must be a version 1.4 library.

TOTAL PRODUCTS

TOTAL UNIVERSAL 2.1

RELEASE DESCRIPTION

TOTAL Universal 2.1 consists of the following relocatable binaries:

- DBGEN (data base generation program) -
this program reads user-prepared DBDL statements and generates COMPASS source statements which in turn produce the data base descriptor module.
- DBFMT (data set format program) -
this program reads format parameter statements, and, using a data base descriptor module, preformats the data sets.
- DATBAS (data base interface module) -
this module serves as an interface between the user application program and the TOTAL and data base descriptor modules.
- TOTAL (data base management module) -
this module provides the data management capability of the system, interpreting and executing the various DML commands from the user application program.
- DBRCV2 (data base recovery module) -
this module, optional in use, provides the ability to recover record images from the TOTAL logging file.
- DBRCV (data base recovery module) -
this module is a COBOL version of DBRCV2 and is being provided as a recovery package that can be modified to meet the user's requirements.
- TOTUTIL (TOTAL utilities) -
this program provides TOTAL users with a generalized utility package capable of performing file loading/unloading, statistics, and other data base functions.

These files are to be installed on the user's permanent file library (refer to Installation Procedure in this section).

Hardware Requirements

TOTAL Universal 2.1 can be maintained and run on the same minimum hardware requirements as NOS 2.

Deficiencies

None.

Release Materials

TOTAL Universal 2.1 release materials are contained on program library tape REL54F. REL54F has the following characteristics: labeled, 7-track with 800 characters per inch (cpi) or 9-track with either 800 or 1600 cpi, binary recording mode, TOTALU2P1 as file ID in HDR1 label. REL54F contains the following records.

- Record 1 - Procedure to install and verify TOTAL
- Record 2 - Procedure and program source for TOTUTIL
- Record 3 - Procedure and program source for DBRCV COBOL version
- Record 4 - Procedure to load TOTAL relocatables to disk
- Record 5 - DBGEN relocatable
- Record 6 - DBFMT relocatable
- Record 7 - DATBAS relocatable
- Record 8 - TOTAL relocatable
- Record 9 - DBRCV relocatable
- Record 10 - Procedure and data to do verify run
- Record 11 - Procedure which creates the file MOVELIB
- Record 12 - Procedure which itemizes all TOTAL files
- Record 13 - Procedure to copy sample dayfile to file OUTPUT
- Record 14 - Procedure to copy sample output to file OUTPUT

INSTALLATION PROCEDURE

Enter the following job to execute the install/verify procedures on the release tape. When the job is completed, validate the install/verify job output against the sample dayfile and output.

```
job command.  
USER,username,password,familyname.  
CHARGE,*.  
LABEL,INSTALL,R,L=TOTALU2P1D= { HY },  
VSN=REL54F. { HD },  
BEGIN,,INSTALL. { PE },  
BEGIN,SAMPDAY,INSTALL.  
BEGIN,SAMPOUT,INSTALL.  
--eor--  
--eoi--
```

Installation Parameters

None.

Installation Job

The installation/validation job performs the following.

1. Issues LABEL command to have install tape assigned to job.
2. Compiles TOTAL utility and creates the relocatable binary on the permanent file TOTUTIL.
3. Compiles COBOL version of the data base recovery program and stores the relocatable binary on the permanent file DBRCV.
4. Loads five TOTAL relocatables from tape to permanent files. The files are DBGEN, DBFMT, DATBAS, TOTAL, DBRCV2.
5. Runs verify job against those TOTAL files stored as permanent files.
6. Saves a file called MOVELIB.
7. Itemizes all of the TOTAL files.
8. Copies sample dayfile to file OUTPUT.
9. Copies sample output to file OUTPUT.

Files Created

The installation/validation job purges and defines the following files.

DBGEN	} Five TOTAL binaries
DBFMT	
DATBAS	
TOTAL	
DBRCV2	
TOTUTIL	TOTAL utility binary
DBRCV	TOTAL recovery binary COBOL version
CUSTDB	Validation DBMOD
CUCUST	} Validation data base files
CUINVF	
MOVELIB	

Prior to installation, ensure that these files will not conflict with already existing files.

TOTAL UNIVERSAL EXTENDED 2.1

RELEASE DESCRIPTION

TOTAL Universal Extended 2.1 consists of the following relocatable binaries.

DBGEN (data base generation program) -
this program reads user-prepared DBDL statements and generates COMPASS source statements which in turn produce the data base descriptor module.

DBFMT (data set format program) -
this program reads format parameter statements, and using a data base descriptor module, preformats the data sets.

DATBAS (data base interface module) -
this module serves as an interface between the user application program and the TOTAL and data base descriptor modules.

TOTAL (data base management module) -
this module provides the data management capability of the system, interpreting and executing the various DML commands from the user application program.

DBRCV2 (data base recovery module) -
this module, optional in use, provides the ability to recover record images from the TOTAL logging file.

DATABASE (data base interface module for transaction processing) -
this module serves as an interface between the user application program and the TOTAL Universal Extended 2 and data base descriptor modules through TRANEX.

TOTALE (data base management module for transaction processing) -
this module provides the data management capability of the system, interpreting and executing the various DML commands from the user application program.

TOTUTIL (TOTAL utilities) -
this program provides TOTAL users a generalized utility package capable of performing file loading/unloading, statistics and other data base functions.

DBRCV (data base recovery module) -
this module is a COBOL version of DBRCV and is being provided as a recovery package that can be modified to meet the user's requirements.

Hardware Requirements

Requirements are the same as the minimum hardware requirements for NOS 2.

Deficiencies

None.

Release Materials

TOTAL Universal Extended 2.1 release materials are contained on program library tape REL54H. REL54H has the following characteristics: labeled, 7-track with 800 cpi or 9-track with either 800 or 1600 cpi, binary recording mode, and TOTALE2P1 as file ID in HDR1 label. REL54H contains seven files:

- Record 1 - Procedure to install and verify TOTAL
- Record 2 - Procedure and program source for TOTUTIL

- Record 3 - Procedure and program source for DBRCV COBOL version
- Record 4 - Procedure to load TOTAL relocatables to disk
- Record 5 - DBGEN relocatable
- Record 6 - DBFMT relocatable
- Record 7 - DATBAS relocatable
- Record 8 - TOTAL relocatable
- Record 9 - DBRCV relocatable
- Record 10 - DATABASE relocatable
- Record 11 - TOTAL E relocatable
- Record 12 - Procedure and data to do verify run
- Record 13 - Procedure which creates the file MOVELIB
- Record 14 - Procedure which itemizes all TOTAL files
- Record 15 - Procedure to copy sample dayfile to file OUTPUT
- Record 16 - Procedure to copy sample output to file OUTPUT

INSTALLATION PROCEDURE

Enter the following job to execute the install/verify procedures on the release tape. When the job has completed, validate the install/verify job output against the sample dayfile and output.

```

job command.
USER,username,password,familyname.
CHARGE,*
LABEL,INSTALL,R,L=TOTALE2P1,D= {HY
                                {HD},
                                {PE}
VSN=REL54F.
BEGIN,INSTALL.
BEGIN,SAMPDAY,INSTALL.
BEGIN,SAMPOUT,INSTALL.
--eor--
--eoi--

```

Installation Parameters

None.

NOTE

TOTALE must always reside under the TAF user name. If the user elects to install under another account number, the file TOTALE must be transferred to the TAF user name.

Installation Job

The installation/validation performs the following.

1. Issues the LABEL command to have the install tape assigned to job.
2. Compiles TOTAL utility and creates the relocatable binary on the permanent file TOTUTIL.
3. Compiles COBOL version of the data base recovery program and stores the relocatable binary on the permanent file DBRCV.
4. Loads seven TOTAL relocatables from tape to permanent files. The files are DBGEN, DBFMT, DATBAS, TOTAL, DBRCV2, DATABASE, TOTALE.
5. Runs verify job against those TOTAL files stored as permanent files.
6. Saves a file called MOVELIB.
7. Itemizes all of the TOTAL files.
8. Copies sample dayfile to file OUTPUT.
9. Copies sample output to file OUTPUT.

Files Created

The installation/validation job purges and defines the following files:

DBGEN	} Seven TOTAL binaries
DBFMT	
DATBAS	
TOTAL	
DBRCV2	
DATABASE	
TOTALE	
TOTUTIL	} TOTAL utility binary
DBRCV	} TOTAL recovery binary COBOL version
MOVELIB	
CUSTDB	} Validation DBMOD
CUCUST	} Validation data base files
CUINVF	

Prior to installation, ensure that these files will not conflict with already existing files.

UNIPLLOT V3.1 PRODUCT OPTIONS

RELEASE DESCRIPTION

UNIPLLOT V3.1, Universal Plotting Software, is a plotting system consisting of two parts, the preprocessor plotting subsystem (UNIPLLOT library) and a postprocessor (UNIPOST).

PREPROCESSOR — UNIPLLOT LIBRARY

The UNIPLLOT library is a set of relocatable graphics subroutines written in FORTRAN 4 extended. The user provides a FORTRAN 4 extended or FORTRAN 5 program that makes calls to the UNIPLLOT library routines producing an intermediate file called the neutral picture file (NPFILE).

The UNIPLLOT library is also designed to support programs making basic CalComp plot calls.

POSTPROCESSOR — UNIPOST

UNIPOST is composed of the postprocessor executive and a set of device drivers. The postprocessor, UNIPOST, reads the NPFILE that was created by the user's program accessing the UNIPLLOT library. A device-dependent plot file (PLOTf) is generated by UNIPOST according to the user's specifications. The placement, scale and rotation of each picture or portion of each picture selected from the NPFILE can be modified.

The user indicates the device to be used by supplying a parameter for the UNIPOST execution control statement or by using a UNIPOST input directive.

UNIPOST STANDARD DEVICE DRIVERS

UNIPOST standard device drivers include four non-graphic device drivers. They are as follows:

- TRACE - A debugging aid.
- CARDIMG - Writes card images.
- DUMP - Dumps the neutral picture file (NPFILE).
- PRINTER - Creates printer plots.

For further information, refer to the UNIPLLOT V3.1 Reference Manual, publication number 60454730 E.

UNIPOST OPTIONAL DEVICE DRIVERS

There are three optional device drivers which can be installed with UNIPLLOT V3.1. The device drivers are the Tektronix 401X series graphics terminals,

Houston Instrument BTC-7 controller with compatible plotters, and the CAL906 controller with compatible plotters.

HARDWARE REQUIREMENTS

The minimum CYBER 170-7XX hardware configuration that is required for NOS is required to support UNIPLLOT V3.1. Also required are the NAM/IAF and/or NAM/RBF communications packages depending upon the device drivers used.

GRAPHICS HARDWARE OPTIONS

A graphics terminal or plotting device is required if displaying of graphics data is to be done on site. The graphics devices currently supported by UNIPLLOT V3.1 are:

- Tektronix 401X series graphics terminals (including 4006)
Keyword: TEK
- Houston Instrument BTC-7/200-UT, BTC-7/734, and BTC-7/18A controllers with compatible plotters
Keyword: HI734 (DP-3 plotter)

Additional keywords:
DP1734 (DP-1 plotter)
DP7734 (DP-7 plotter)
DP8734 (DP-8 plotter)
DP9734 (DP-9 plotter)
HI200 (DP-1 plotter)

- CalComp 906 controller and compatible plotters
Keyword: CAL906

Additional keywords: C6936, C6960, C6970, C61012, C61037, C61039, C61051, C61055, C61060, C61065

In general, any Tektronix, Houston Instrument, or CalComp plotter that is compatible with the above mentioned controller is supported with UNIPOST directives such as SURFACE, PEN, and INCREMENT.

For further information about the device hardware characteristics refer to the UNIPLLOT V3.1 Reference Manual.

COMMUNICATIONS

All limitations applicable to NOS 2 and NAM/IAF/RBF also apply to UNIPLLOT V3.1.

Communications between the graphical device and central site are supported for UNIPOST according to table UNIPLLOT V3.1-1.

**TABLE UNIPLLOT V3.1-1
UNIPOST COMMUNICATIONS CAPABILITIES**

Tektronix 401X	Asynchronous	NAM/IAF 300, 1200, 4800, 9600
Calcomp 906	Asynchronous	NAM/IAF 300, 1200, 4800, 9600
Houston Instrument BTC-7	Synchronous	NAM/RBF 2000, 4800

RELEASE MATERIALS

UNIPLLOT V3.1 SYSTEM

UNIPLLOT V3.1 resides on the tape known as REL66D. REL66D has the following characteristics: 7-track with 800 characters per inch (cpi) or 9-track with either 800 or 1600 cpi, binary recording mode, UNIPLLOTV31R040282 as file ID in HRD1 label, and 11 files:

File 1 - CCL (CYBER Control Language) procedure, INSTALL for the following tasks:

- 1) loading the contents of REL66D onto the target installation machine,
- 2) creating the device hardware characteristics file, (DHCFILE),
- 3) adding optional device driver binaries to the relocatable binaries for UNIPOST (POSTLGO),
- 4) extending the DHCFILE based on the device drivers optionally included in the UNIPLLOT V3.1 system,
- 5) creating UNIPOST, and
- 6) perform the following tasks when the user runs the verifications of the installation:
 - a) verify the UNIPLLOT library, and UNIPOST,
 - b) UNIPLLOT V3.1 system verification which generates a plot on a user specified device driver.

File 2 - CCL (CYBER Control Language) procedure, UNIPROC, for accessing the UNIPLLOT library and executing UNIPOST,

File 3 - UNIPLLOT library relocatable binaries with metric units,

File 4 - POSTLGO, the relocatable binaries for the UNIPOST executive and the four standard non-graphic device drivers with metric units,

File 5 - UNIPLLOT library relocatable binaries with English units,

File 6 - POSTLGO, the relocatable binaries for UNIPOST executive and the four standard non-graphic device drivers with English units,

File 7 - CDHCF0, binaries to create the device hardware characteristics file (DHCFILE),

File 8 - MDHCF0, binaries to modify the device hardware characteristics file (DHCFILE),

File 9 - VERPROG, UNIPLLOT verification program,

File 10 - VERNPF, verification NPFIL with inch units, and

File 11 - VERPLTF, verification plot file (PLOTFF).

TEKTRONIX 401X DEVICE DRIVER (OPTIONAL)

A Tektronix 401X series terminal must be available for displaying graphics data.

The Tektronix 401X device driver option resides on the tape known as REL66E. REL66E has the following characteristics: 7-track with 800 cpi or 9-track with either 800 or 1600 cpi, binary recording mode with TEK0282 as file ID in HRD1 label, and three files:

File 1 - DHCFILE information about the device driver,

File 2 - TEK device driver relocatable binaries, and

File 3 - TEK device driver source code.

HOUSTON INSTRUMENTS BTC-7 DEVICE DRIVER (OPTIONAL)

A Houston Instrument BTC-7/200-UT, BTC-7/734 or BTC-7/18A controller with an appropriate CDC RJE terminal (200-UT, CDC734, OR CYBER 18) and a compatible plotter must be available for displaying graphics data.

The Houston Instrument BTC-7 device driver option resides on the tape known as REL66F. REL66F has the following characteristics: 7-track with 800 cpi or 9-track with either 800 or 1600 cpi, binary recording mode with HI7340282 as file ID in HRD1 label, and three files:

File 1 - DHCFILE information about the device driver,

File 2 - HI734 device driver relocatable binaries, and

File 3 - HI734 device driver source code.

CALCOMP 906 DEVICE DRIVER (OPTIONAL)

A CalComp 906 controller and a compatible plotter must be available for displaying graphics data.

The CalComp 906 device driver option resides on the tape known as REL66G. REL66G has the following characteristics: 7-track with 800 cpi or 9-track with either 800 or 1600 cpi, binary recording mode, with CAL9060282 as file ID in HRD1 label, and three files:

- File 1 - DHCFILE information about the device driver,
- File 2 - CAL906 device driver relocatable binaries, and
- File 3 - CAL906 device driver source code.

INSTALLATION PROCEDURE

The installer must ensure that no permanent files exist with the same names as the files generated in the installation procedure. Permanent files generated during installation and for verification are: INSTALL, UNIPROC, UNIPLOT, POSTLGO, UNIPOST, DHCFILE, MDHCFO, VERPROG, VERNPF, and VERPLTF.

All programs and CCL procedures in the UNIPLOT V3.1 system are set up to be installed under and accessible from username APPLLIB. The same density/track tapes should be obtained for the UNIPLOT installation with device drivers. To install UNIPOST V3.1, the following three job steps must be run from the system console.

Step 1. Enter the following console commands.

```
X.DIS
SUI,377774.
LABEL,REL66D,L=UV31R040282,
D= { HY
    HD },VSN=REL66D,PO=R,R.
    PE }
REWIND,REL66D.
COPYBF,REL66D,INSTALL.
VERIFY,REL66D,INSTALL,N=1,R,A.
```

Step 2. Create a local file named INST, at the console, which contains the following two records:

```
.PROC, INST.
BEGIN,,INSTALL, parameters
```

where the parameter descriptions are as follows:

PARAMETER DESCRIPTIONS

Option	Definition
UNIT	If installing the metric versions of the UNIPLOT library and UNIPOST, specify UNIT=CM. Default (UNIT=INCH) will generate the English versions of the UNIPLOT library and UNIPOST.
D	Tape density. Default is D=PE for 9-track, 1600 cpi tape. Specify D=HD for a 9-track, 800 cpi tape. Specify D=HY for a 7-track, 800 cpi tape.

TABLE UNIPLOT V3.1-2 UNIPLOT V3.1. PERMANENT FILES

Permanent File Name	Access Type	Category (CT)	Mode (M)	Password	Contents
INSTALL	INDIR	PU	R	None	CCL procedures for installation.
UNIPROC	INDIR	PU	R	None	CCL procedure for accessing the UNIPLOT library and executing UNIPOST.
UNIPLOT	INDIR	PU	R	None	UNIPLOT library.
POSTLGO ¹	DIR	PU	R	None	UNIPOST relocatable binaries.
UNIPOST	DIR	PU	E	None	UNIPOST absolute binaries.
DHCFILE	DIR	PU	R	None	Device hardware characteristics file.
MDHCFO	INDIR	PU	E	None	MDHCFO relocatable binaries.
VERPROG ²	INDIR	PU	R	None	Verification program.
VERNPF ²	INDIR	PU	R	None	Verification V3.1 NPFILE.
VERPLTF ²	INDIR	PU	R	None	Verification plot file (PLOTf).

¹ POSTLGO may include optional device driver relocatable binaries if any are installed.
² Following verification execution, these files may be purged.

- TEK If installing the Tektronix device driver, specify TEK=REL66E. (Default does not install this.)
- HI734 If installing the Houston Instrument device driver, specify HI734=REL66F. (Default does not install this.)
- CAL906 If installing the CalComp device driver, specify CAL906=REL66G. (Default does not install this.)

Execution of verification tests for the UNIPLOT library, UNIPOST, and the device drivers installed, may be run using VERPROC of the CCL procedure file INSTALL stored on the machine during the installation run.

UNIPLOT INSTALLATION VERIFICATION

This section describes the UNIPLOT verification procedure. The UNIPLOT V3.1 CCL procedure file, UNIPROC, will be used to access the UNIPLOT library to generate an NPFIL by executing the verification program (VERPROC) and to execute UNIPOST. To execute the installation verification, run

When the above installation job has completed execution, the following permanent files table should appear on UN=APPLIB.

```
GET,INSTALL/UN=APPLIB.
BEGIN,VERPROC,INSTALL.
```

Step 3. Enter the following control card at the console.

```
BEGIN,,INST.
```

This procedure will compile the verification program (VERPROC), load the program with the UNIPLOT library, and execute the program. Also, UNIPOST is executed using the PRINT6 device driver to create a PLOT6 file (printer plot file), and an INFORM listing of the NPFIL is generated. The NPFIL and PRINT6 PLOT6 files generated at this time will be verified against NPFIL and PRINT6 PLOT6 files that were supplied on the installation tape. Note that the NPFIL and PRINT6 PLOT6 files that were included in the installation tapes were also created by using the same verification program (VERPROC).

VERIFICATION PROCEDURES

Once the UNIPLOT V3.1 has been installed and the installation job output listing is available, the installation testing may begin.

PICTURE AND FIGURE DATA							
NPFIL RELEASE 04				NPFIL UNIT = INCH			
PICTURE NO.	PICTURE NAME		ROTATION	LEVEL			
1	PICTURE1		NO	1			
X ABS	Y ABS	X REL	Y REL	X MIN	Y MIN	X MAX	Y MAX
0.0000	0.0000	0.0000	0.0000	0.0000	0.0000	1.0000	1.0000
FIGURE NO.	X ORIG		Y ORIG				
1	0.0000		0.0000				
FIGURE NO.	X ORIG		Y ORIG				
2	0.0000		0.0000				
FIGURE NO.	X ORIG		Y ORIG				
3	.5000		.5000				
PICTURE NO.	PICTURE NAME		ROTATION	LEVEL			
2	PICTURE2		NO	1			
X ABS	Y ABS	X REL	Y REL	X MIN	Y MIN	X MAX	Y MAX
2.0000	0.0000	2.0000	0.0000	1.0000	1.0000	2.0000	2.0000
FIGURE NO.	X ORIG		Y ORIG				
1	1.1000		1.1000				
PICTURE NO.	PICTURE NAME		ROTATION	LEVEL			
3	PICTURE3		NO	1			
X ABS	Y ABS	X REL	Y REL	X MIN	Y MIN	X MAX	Y MAX
4.0000	0.0000	2.0000	0.0000	-1.0000	-1.0000	1.0000	1.0000
FIGURE NO.	X ORIG		Y ORIG				
1	0.0000		0.0000				
===== END OF INFORM =====							

Figure UNIPLOT V3.1-1. VERPROC INFORM

The output listing from this procedure includes an INFORM listing of the NPFILe as shown in figure UNIPLOT V3.1-1 and VERIFY (NOS utility) error list, as shown in table UNIPLOT V3.1-3.

The dayfile from this procedure should show VERIFY ERRORS from the VERIFY utility for the NPFILe verify and VERIFY GOOD for the PLOTf verify.

The NPFILe has the jobname, creation date, creation time, and NPFILe unit (INCH or CM) identification records. The jobname, creation date and time will result in verify errors. However, the unit verification with respect to INCH may pass or fail depending upon the installation option chosen for the UNIT parameter. These verify errors are acceptable. For example, the VERIFY ERRORS shown in octal format in table UNIPLOT V3.1-3 have the alpha representation of:

VERNPF	NPFILe
82/01/26.	82/01/27.
14.53.56.	09.15.00
INCH	CM

DEVICE DRIVER VERIFICATION

This section describes the device driver verification procedure. For each device driver installed, run the following procedure by substituting the appropriate device driver keyword for "device".

```
GET,INSTALL/UN=APPLLIB.
BEGIN,VERDEVC,INSTALL,D=device.
```

where:

device = is the device keyname for the device driver being verified.

The plot generated should look like figure UNIPLOT V3.1-2.

Note that the installer must dispose the PLOTf file to the RJE terminal for plotting on the Houston Instrument plotter.

VERIFICATION FILE PURGE

Following the verification of a successful installation, the verification files VERPROG, VERNPF, and VERPLTF may be eliminated as permanent files.

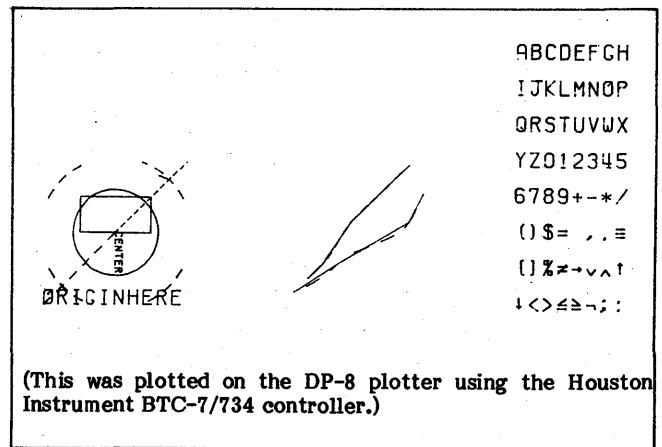

Figure UNIPLOT V3.1-2. Verification Plot

UNIPLOT ACCESS PROCEDURES

The UNIPLOT CCL procedures used to execute UNIPLOT V3.1 are on the file named UNIPROC. UNIPROC consists of the following three procedures: UNIPRE, UNIPOST, and UNIPLOT. The UNIPROC procedure file should be attached from the username APPLLIB that UNIPLOT V3.1 was installed on, for example:

```
GET,UNIPROC/UN=APPLLIB.
```

The UNIPRE procedure is used to compile and load a FORTRAN 4 or FORTRAN 5 program with the UNIPLOT library, and execute the program to create an NPFILe (preprocess). To execute UNIPRE, run the following procedure.

```
BEGIN,UNIPRE,UNIPROC,C=ifn.
```

where:

ifn = the local file name of the source code.

Example:

```
BEGIN,UNIPRE,UNIPROC,C=EXAMPLE.
```

The UNIPOST Procedure is used to postprocess an NPFILe and generate a device-dependent plot file (PLOTf). To execute UNIPOST, run the following procedure.

```
BEGIN,UNIPOST,UNIPROC,D=device,F=input.
```

TABLE UNIPLOT V3.1-3. VERIFICATION "VERIFY ERRORS"

VERIFY ERROR LIST. RECORD WORD		DATA FROM VERNPF TEXT/NPF V3.	82/01/27.09.17.01. DATA FROM NPFILe TEXT/NPF V3.
1	20B	5543 3550 3334 5035 4157	5543 3550 3334 5035 4257
1	21B	5534 3757 4036 5740 4157	5533 4457 3440 5733 3357
1	23B	1116 0310 5555 5555 5555	0315 5555 5555 5555 5555
1	120B	5543 3550 3334 5035 4157	5543 3550 3334 5035 4257
1	121B	5534 3757 4036 5740 4157	5533 4457 3440 5733 3357
1	123B	1116 0310 5555 5555 5555	0315 5555 5555 5555 5555
1	220B	5543 3550 3334 5035 4157	5543 3550 3334 5035 4257
1	221B	5534 3757 4036 5740 4157	5533 4457 3440 5733 3357
1	223B	1116 0310 5555 5555 5555	0315 5555 5555 5555 5555
1	323B	1116 0310 5555 5555 5555	0315 5555 5555 5555 5555
VERIFY ERRORS.			

where:

device = the device keyname for the device driver.
input = the file for UNIPOST Input directives.

Example:

```
BEGIN,UNIPOST,UNIPROC,D=CARDIMG,I.
```

The UNIPLOT procedure is used to perform the functions of UNIPRE and UNIPOST. To execute UNIPLOT, run the following procedure.

```
BEGIN,UNIPLOT,UNIPROC,C=Ifn,D=device,F=input.
```

where:

Ifn = the local file name of the source code.
device = the device keyname for the device driver.
input = the file for UNIPOST Input directives.

For further information, refer to the UNIPLOT V3.1 Reference/User Guide.

USER DEVELOPED DEVICE DRIVER INTERFACE

UNIPLOT V3.1 software system, by its design, allows the installation of a user's device driver. This section describes how the user can develop a device driver and add it to the existing UNIPOST.

UNIPOST STRUCTURE

UNIPOST has an overlay structure. Each device driver is a secondary overlay. The UNIPOST postprocessor reads vector and character strings from the UNIPLOT neutral picture file (NPFILE), reads and processes input directives, and keeps overall execution control.

The first card in a device driver is the overlay directive. In developing a device driver, the overlay directive is to be created as follows:

```
OVERLAY (UNIPOST, 10, 20)
```

The device driver is comprised of a device control routine (DCR) and the hardware vendor supplied plotter routines. The device control routine provides links between the UNIPOST postprocessor and the appropriate vendor routines. It is this device control routine which must be developed.

A labeled common block, QXPRQC, is used to communicate between the device driver and the UNIPOST postprocessor. Each time control is returned to the device overlay, QXPRQC contains information which directs the device overlay program to call a specific vendor routine.

The QXPRQC common block is defined as follows:

```
COMMON /QXPRQC / IREQ, IPRM(31)  
DIMENSION FPRM(31)  
EQUIVALENCE (IPRM(1), FPRM(1))
```

where:

IREQ = an integer whose value specifies the specific request being made to the device driver.
IPRM = an array that contains integer parameters to be used in carrying out the request.
FPRM = the same array for floating point parameters to be used in carrying out the request.

Execution flow begins with the device driver initially getting control through its FORTRAN program statement. If the user specified the device keyword on the UNIPOST control statement, the device driver gets control initially before any prompting or processing of input directives.

Otherwise, the device driver gets control initially after input directive processing has begun.

After the device driver has been initialized, a call is made to the UNIPOST executive subroutine, NPFDATA, as follows:

```
CALL NPFDATA
```

On return from NPFDATA, the labeled common block, QXPRQC, contains the next request for the device driver. Following the processing of this request, the device driver again calls NPFDATA. Control continues to flow between UNIPOST and the device driver through the calls to NPFDATA.

The final request to the device driver is a vector request with a third parameter of 999 (see the Vector subsection for more detail). Following the processing of this request, the device driver transfers control back to UNIPOST by executing the END statement in the overlay program.

UNIPOST DEVICE DRIVER REQUESTS

All possible requests that the UNIPOST postprocessor passes through the labeled common block, QXPRQC, are discussed in this section.

INITIALIZATION (IREQ=0)

The initialization request is the first request sent by the UNIPOST postprocessor to the device control routine (DCR). Upon entry with IREQ=0, the IPRM array is set as follows:

IPRM(30) = device keyname, 1-7 characters (left-justified with blank fill).
IPRM(31) = name of the device dependent plot file (left-justified with zero fill) to be used only with CIO; default is PLOTFF.

If the device-dependent routines use FORTRAN I/O, logical unit 4 should be used.

If the DCR is being written to override the default parameters established by the data stored in the device keyname record of the DHCFIL, then the following values in QXPRQC must be returned to the UNIPOST postprocessor from this initialization request.

- IPRM(1) = device type: 1 for drum plotter (linear mode default)
2 for table plotter (file mode default)
3 for storage tube display (selective mode default)
4 for microfilm device (selective mode default)
- FPRM(2) = display surface extent in X-direction in inches or centimeters depending on IPRM(12)
- FPRM(3) = display surface extent in Y-direction in inches or centimeters
- IPRM(4) = number of pens
- IPRM(5) = is there hardware character generation?
0 = no 1 = yes
- IPRM(6) = are there hardware-generated dotted lines?
0 = no 1 = yes
- IPRM(7) = are there hardware-generated dashed lines?
0 = no 1 = yes
- IPRM(8) = is there hardware arc generation?
0 = no 1 = yes
- IPRM(9) = is there hardware cubic generation?
0 = no 1 = yes
- IPRM(10) = number of increments per device unit of measure
(i.e., 100, 200, 400, ...)
- IPRM(11) = normal mode of operation
0 = batch processing
1 = interactive processing
- IPRM(12) = device driver unit of measure
0 = inch
1 = centimeter

The DCR then calls the routine, NPFDATA, in the UNIPOST postprocessor which transfers the above information into the appropriate variables if override of the DHCFILE defaults is allowed.

The UNIPOST postprocessor takes appropriate action, eventually returning through NPFDATA with another device driver request. It is recommended to delay calling the vendor plotting initialization routine until UNIPOST returns from the first NPFDATA call.

VECTOR (IREQ = 1)

The vector request provides the arguments necessary for a call to the CalComp standard subroutine PLOT or its equivalent. A value of 999 in IPRM(3) indicates that the current request is the final request in the run, and buffers should be flushed, files closed, etc., as required and the DCR ended.

- FPRM(1) = X-coordinate
- FPRM(2) = Y-coordinate

- IPRM(3) =vector type:
2 for solid line
3 for invisible line
4 for dashed line
5 for dotted line
-3 for new picture
999 for end of run

A dashed or dotted vector (IPRM(3) = 4 or 5) is requested only if the presence of those features was indicated for the device driver, and DASH=HARD/DOT=HARD directives are in effect. Otherwise, the UNIPOST postprocessor draws the lines as a series of pen up/pen down vector requests.

NEWPEN (IREQ = 2)

A call to the CalComp standard subroutine NEWPEN or its equivalent is requested.

- IPRM(1) = pen number (pen number is always greater than zero)
- IPRM(2) = maximum number of pens

The maximum number of pens is either the default value for this device keyname or the value specified from the PEN=input directive.

TEXT (IREQ = 3)

This request provides the overlay with the parameters needed for a character string call to the CalComp standard subroutine SYMBOL (only if hardware character generation is available on the device). Up to 200 characters may be present in each request. The X and Y coordinates have values of 999.0, indicating that the string is to be started at the current pen position. Centered symbols are not included in this type of request.

- FPRM(1) = X-coordinate of start of character string
- FPRM(2) = Y-coordinate of start of character string
- FPRM(3) = character height
- FPRM(4) = angle of baseline of character string in degrees
- IPRM(5) = number of characters
- IPRM(6)-IPRM(25) = text character string left-justified
- FPRM(26) = character width

The device driver will only get this request if the device supports hardware generated characters, and then only if a CHAR=HARD directive is in effect (CHAR=SOFT is the default). When a CHAR=SOFT directive is in effect, UNIPOST will stroke each character (send down a series of vector requests IREQ=1).

DEVICE MODE (IREQ = 4)

This request provides the parameters necessary to make a call to a special vendor specific subroutine. The DCR should inspect IPRM(1) which contains the name

of the vendor specific routine in left-justified A10 format. Assuming that the device driver supports the routine, it will then call the specified routine using the subsequent words of IPRM (FPRM if an argument is of type REAL) as the arguments. The elements of the array (IPRM and/or FPRM) are used in ascending order from left to right in the subroutine argument list.

IPRM(1) = name of subroutine; A10 format, left-justified (exactly what was entered on the NPFILF from a QXDEVI call)

IPRM(2)-IPRM(9) = subroutine arguments

FPRM(2)-FPRM(9) = subroutine arguments

REORIGIN REQUESTS (IREQ = 5)

This request is used primarily by CRT type display devices. Whenever a new picture is being processed, this request is made to allow the DCR to clear the CRT screen. The decision to clear the CRT screen should be made based on the overplot flag which is controlled by the OVERPLOT input directive.

IPRM(1) = overplot flag
 0 = do not overplot; erase screen.
 1 = overplot; do not erase screen.

IPRM(3) = 0 = this is the middle of a picture list
 1 = this is the start of a picture list
 2 = this is the end of a picture list

A picture list is the set of pictures selected when a DRAW, DELETE or INFORM directive is processed. (INFORM is not applicable for reorigin requests.)

INCREMENT (IREQ = 6)

This request passes the value of the plotter increment size, specified by an INCREMENT input directive, to the DCR.

The DCR may, on the basis of this value, call a FACTOR routine to adjust the size of the finished plot.

FPRM(1) = plotter increment size in device measurement units (i.e., .01, .005, or .0025)

Increment requests are not sent unless they are different from the current increment.

PEN RESTORE (IPREQ = 7)

This request instructs the DCR to call a routine to move the pen to the bottom of the plotter.

ARC (IREQ = 8)

This request provides the overlay with the parameters needed for the vendor software to perform a hardware arc request. This request will only be made if the device driver supports hardware arcs and if an ARC=HARD directive is in effect (default setting is ARC=SOFT). When an ARC=SOFT directive is in effect, each arc is drawn as a series of pen strokes (vector requests IREQ=1).

FPRM(1) = X-coordinate of center of arc

FPRM(2) = Y-coordinate of center of arc

FPRM(3) = X-coordinate of start point of arc

FPRM(4) = Y-coordinate of start point of arc

FPRM(5) = angle swept by the arc in degrees (A positive angle indicates counterclockwise rotation and a negative angle indicates clockwise rotation.)

IPRM(6) = line style of the arc
 2 = solid line
 3 = invisible line
 4 = dashed line
 5 = dotted line

DEVICE CONTROL ROUTINE EXAMPLE

Following is an example of a device control routine (DCR) for a device driver.

```

OVERLAY (UNIPLOT, 10, 20)
PROGRAM CALXXX
C
C  DEVICE OVERLAY FOR A CALYYY OFFLINE CONTROLLER.
C
C  WITH AN XXX PLOTTER.
C
C  THE OVERLAY GENERATES AN HCBS TAPE.
C
C  COMPATIBLE FILE
C
COMMON /QXPRQC/ IREQ, IPRM(31)
DIMENSION FPRM (31)
EQUIVALENCE (IPRM, FPRM)
C
C  INITIALIZATION.
C
C  GET Y DEVICE LIMIT AND INCREMENT  SIZE STEP.
C
YLIM = FPRM(3)
STEP = FLOAT(IPRM(10))
C

```

```

CALL PLOTS (0,0,4)
GO TO 999
C
C PROCESS REQUEST FROM THE UNIPOST POSTPROCESSOR.
C
10 CONTINUE
IF (IREQ.LT.1.OR.IREQ.GT.8) GO TO 999
GO TO (100, 200, 300, 400, 500, 600, 700, 800), IREQ
C VECTOR REQUEST
100 CONTINUE
CALL PLOT (FPRM(1), FPRM(2), IPRM(3))
C CHECK FOR END OF RUN
IF (IPRM(3).EQ.999) GO TO 9999
GO TO 999
C NEWPEN
200 CONTINUE
IF(IPRM(1).LE.(IPRM(2)) CALL NEWPEN(IPRM(1))
GO TO 999
300 CONTINUE
C PROCESS 999 FOR CHARACTERS IN A NON-CALCOMP UNIPLOT METHOD
C
X = FPRM(1)
Y = FPRM(2)
CALL WHERE (X1, Y1, FACT)
IF (X.EQ.999) X=X1
IF (Y.EQ.999) Y=Y1
CALL SYMBOL (X,Y,FPRM(3),IPRM(6),FPRM(4), IPRM(5))
GO TO 999
400 CONTINUE
C NO DEVICE MODE CAPABILITY
GO TO 999
500 CONTINUE
C IGNORE REORIGIN REQUEST
GO TO 999
600 CONTINUE
C INCREMENT CHANGE
FAC = 1.0/(FPRM(1)*STEP)
CALL FACTOR(FAC)
GO TO 999
700 CONTINUE
C PEN RESTORE
CALL PLOT (0., -YLIM, -3)
GO TO 999
800 CONTINUE
C NO ARC CAPABILITY
999 CONTINUE
C GET DATA FROM UNIPOST
CALL NPFDATA
GO TO 10
9999 CONTINUE
END
.
.
.
VENDOR CODE

```

USER DEVELOPED DEVICE DRIVER INSTALLATION

This section describes the necessary procedure for installing a user developed device driver to the existing UNIPOST. The steps necessary to add a device driver are as follows:

- 1) Develop the device driver control routine (DCR) which links the UNIPOST postprocessor and the vendor plotting routines.
- 2) Compile the DCR program together with the vendor plotting routines to generate relocatable binaries.
- 3) Generate a file containing the device driver's hardware characteristics for DHCFILE extension

(see Device Hardware Characteristics File section).

- 4) Execute the installation procedure, ADDUSER, to add the user developed device driver as described in the section INSTALLATION PROCEDURE.

DEVICE HARDWARE CHARACTERISTICS FILE (DHCFILE)

When adding a device driver, the DHCFILE must be extended to include the device driver's hardware characteristics. The device hardware characteristics file (DHCFILE) contains all the pertinent hardware characteristics for each device keyword. Table UNIPLOT V3.1-4 shows the layout of the DHCFILE. This section describes the method used to extend the DHCFILE.

TABLE UNIPLLOT V3.1-4 DHCFILE ORGANIZATION

- 1) Header Record - 16 words
 Words 1-4 - Reserved for CDC
 Word 5 - 7L DHCF KEY (left justified with zero fill)
 Words 6-16 - Reserved for CDC
- 2) Keyword Records - 16 words

WORD

- 1 Device overlay number
- † 2 Plotter type number
- † 3 Number of pens
- † 4 Number of increments per unit
- 5 Keyword (left justified with blank fill)
- † 6 X-dimension of plotter
- † 7 Y-dimension of plotter
- † 8 Normal mode of operation (batch/interactive)
- 9 Device driver override of DHCFILE values
- † 10 Hardware character support
- † 11 Hardware dotted line support
- † 12 Hardware dashed line support
- † 13 Hardware arc support
- † 14 Hardware cubic support
- † 15 Device units (English/metric)
- 16 Reserved for CDC

† If device driver override is permitted, the device driver sets these values.

The file, MDHCF0, contains a relocatable program which modifies or adds device driver keyword data to the

DHCFILE. Table UNIPLLOT V3.1-5 lists the order and formats of values expected for the input file to MDHCF0.

TABLE UNIPLLOT V3.1-5. MDHCF0 INPUT FORMAT (Sheet 1 of 2)

Order	Name	Format	Range
1	Overlay Number	O4	08-77778
2	Device type	I1	1-4
3	Number of pens	I1	1-9
4	Increment/unit	I3	0-999
5	Device keyword	A10	-----
6	Maximum X-Surface	F5.0	0.-99999.
7	Maximum Y-Surface	F3.0	0.-999.
8	Interactive capability	A10	YES/NO
9	Override capability	A10	YES/NO

TABLE UNIPLLOT V3.1-5. MDHCF0 INPUT FORMAT (Sheet 2 of 2)

Order	Name	Format	Range
10	Hardware character support	A10	YES/NO
11	Hardware dot line support	A10	YES/NO
12	Hardware dash line support	A10	YES/NO
13	Hardware arc support	A10	YES/NO
14	Hardware cubic support	A10	YES/NO
15	Unit type (YES=CM,NO=IN)	A10	YES/NO

Note that only one value may be entered per line. After these values have been entered, the DHCFILE is searched for the record containing the specified overlay number and device keyword. If the record is found, it is replaced by the specified values.

If the record is not found, the new record is appended. See the following example for the file USERDHC.

Example:

```
1022
1
3
500
KEYNAME
1400.
34.5
YES
YES
YES
NO
NO
YES
NO
NO
```

Note that the overlay number consists of primary and secondary numbers. For user overlay numbers, use the primary number 10, and for the secondary number use any number from 20 to 77. An example of a user overlay card is:

OVERLAY (UNIPOST, 10[†], 22[†])

INSTALLATION PROCEDURE

The installation procedure, ADDUSER, which adds a user developed device driver, will extend the DHCFILE and rebuild UNIPOST to include the device driver binaries. To execute the installation procedure, run the following three job steps:

Step 1. Enter the following console commands.

```
X.DIS.
SUL377774.
GET,INTALL/UN=APPLLIB.
```

Step 2. Create a local file named INSADD, at the console, which contains the following two records:

```
.PROC,INSADD.
BEGIN,ADDUSER,INSTALL,USERDHC=
pfn1,USERLGO=pfn2,UN=USERNM.
```

where:

pfn1 = the permanent file name containing the device driver's hardware characteristics information as described in the table UNIPLLOT V3.1-5.

pfn2 = the permanent file name containing the device driver binaries.

These permanent file names can be one to seven alphanumeric characters.

Step 3. Enter the following control card at the console.

```
BEGIN,,INSADD.
```

SAMPLE TEK HARDWARE CONFIGURATION

The following conventions and procedures pertain to the on-line interactive use of the Tektronix 4014 Display Terminal. The display measures 15 inches horizontally by 11 inches vertically. The 4014 and 4014-1 are identical except that the 4014-1 can be used with a hard copy unit.

Configuring the Equipment

Strappable options are found on circuit cards in the top section of the pedestal. Access to the cards is obtained by loosening the top screws in the front cover and swinging the cover down. The strap options will vary according to type of communications interface installed. The strap options are set by plastic coated metal clips which fit down over metal contacts for option selections.

[†]The overlay number should correspond with the device driver overlay card number, where the first two digits are for the primary overlay number and the last two digits are for the secondary overlay number.

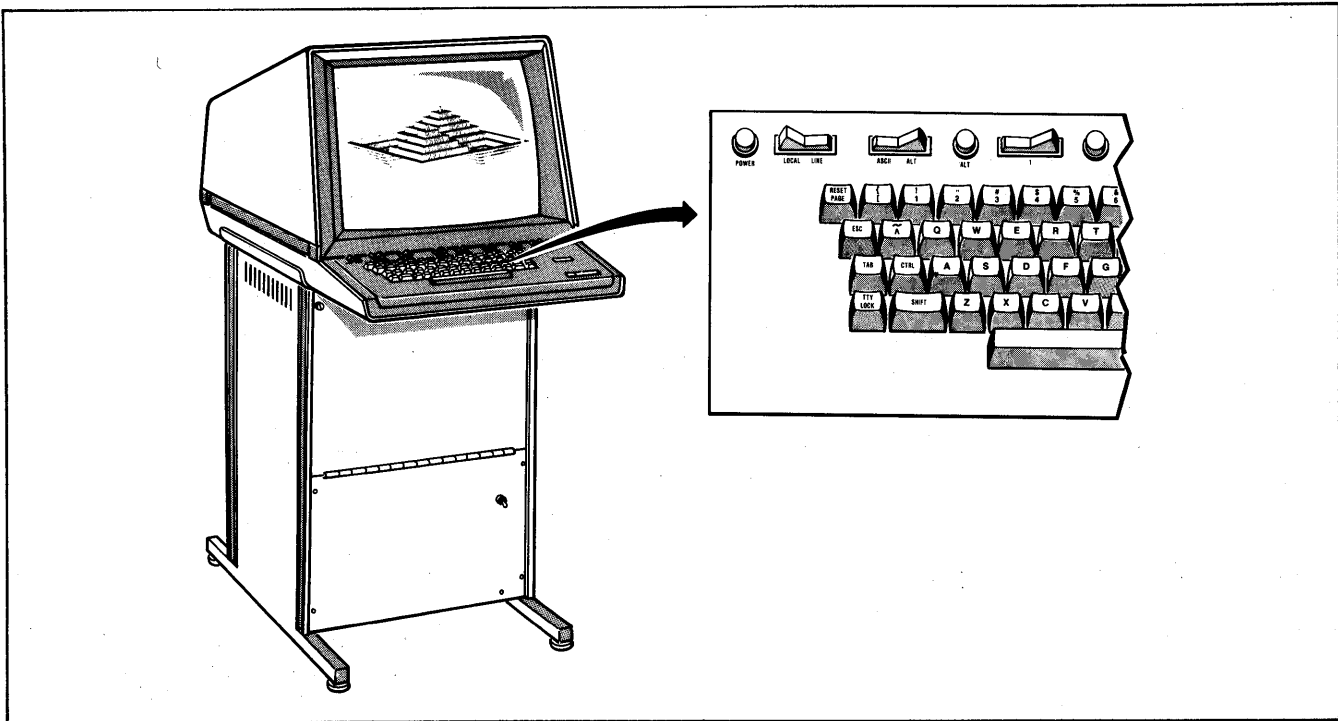

Figure UNIPLOT V3.1-3. Display Terminal

If the Standard Communications Interface is installed, set the following strap options.

DATA COMMUNICATIONS INTERFACE BOARD	
OPTION	SETTING
XMIT	1200
REC	1200
ECHO	IN
PAGE FULL BREAK	OUT

TC-1 BOARD	
OPTION	SETTING
CR EFFECT	CR
LOW ORDER Y	DEL-LOY
LF EFFECT	LF
CHARACTER TYPE	NORMAL

TC-2 BOARD	
OPTION	SETTING
GIN TERMINATIONS	NONE

If the Option 1 Communications Interface is installed, set the following strap options and set the following switches on the back of the pedestal:

OPTION 1 BOARD	
OPTION	SETTING
TTY MASTER	OFF
BIT 8	OFF
PARITY	EVEN
PFB (Page Full Break)	OFF
ECHO	ON
TURN-A-ROUND	OFF
CHARACTER	OFF
CLK (Clock)	X16
XSRC (External Clock Source)	XSW

TC-1BOARD	
OPTION	SETTING
CR EFFECT	CR
LOW ORDER Y	DEL-LOY
LF EFFECT	LF
CHARACTER TYPE	NORMAL

TC-2 BOARD	
OPTION	SETTING
GIN TERMINATIONS	NONE

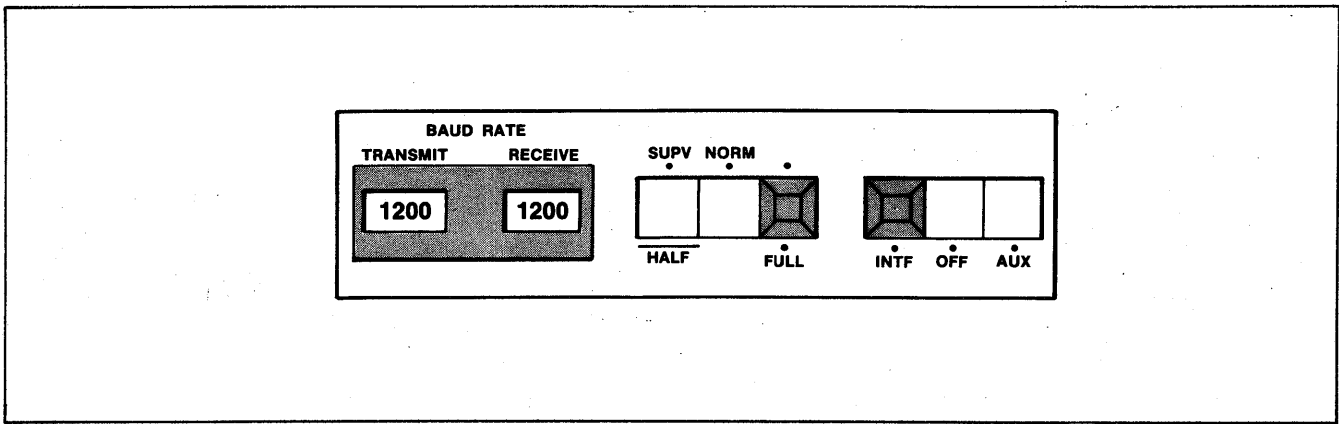

Figure UNILOT V3.1-4. Pedestal Switches

Connecting the Equipment

The modem cable is supplied with the terminal and directly connected to the communications interface board. Connect the other end of the cable to the modem.

Connect the power cord to the proper power source and power-up the terminal. The power indicator, on the upper left corner of the keyboard, should light. The power switch is located on the lower right front of the pedestal.

Set the two switches to the right of the power-on indicator to LINE and ASCII.

Depress the TTY LOCK key and then depress RESET/PAGE key to clear the screen.

SAMPLE H1734 HARDWARE CONFIGURATION

The following conventions and procedures pertain to the use of the DP-3-1 plotter/BTC-7/18A plotter controller on-line with a CDC CYBER 18 systems emulating a 200 UT or HASP protocol. This plotter operates with 22-inch fanfold paper and with one pen. It is a desk top unit.

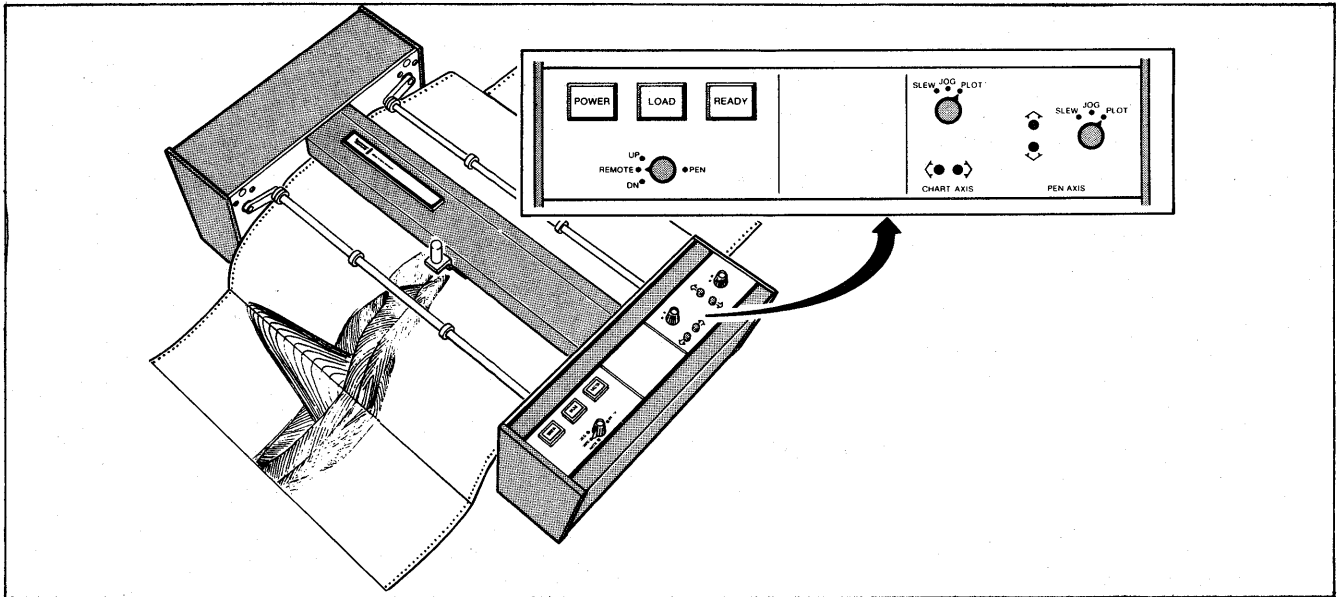

Figure UNILOT V3.1-5. Front View and Control Panel

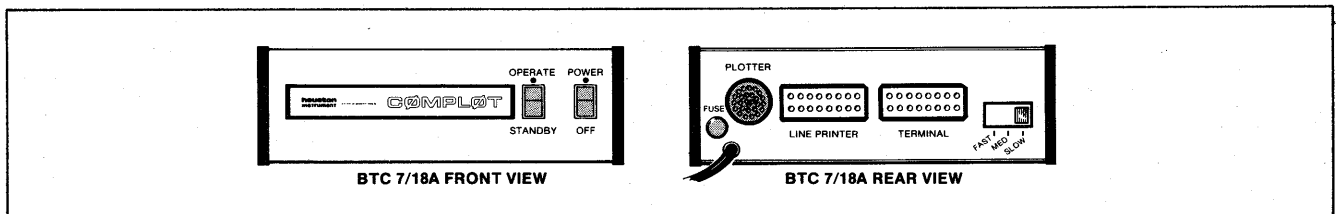

Figure UNILOT V3.1-6. Controller External Switches, Indicators and Connectors

Materials received with controller/plotter

BTC 7/18A controller

- CDC printer cable
- Plotter cable
- 2 punched cards
- Operation and maintenance manual

DP-3-1 plotter

- Power cord
- Dust cover
- Pen kit and paper
- Operation and maintenance manual

Option:

- RC-3 roll chart adapter

Connecting the Equipment

1. Disconnect the cable from connector 8J01 on the lower left rear of the printer.
2. Connect that connector to TERMINAL connector on the rear of the controller.
3. Connect printer cable supplied with the controller to LINE PRINTER connector on controller and 8J01 on the printer. If a printer is not available, obtain a dummy terminator plug from HL.
4. Connect plotter cable between the controller connector labeled PLOTTER and the plotter.

Off-Line Testing of Plotter

1. Connect the power cords of the plotter and controller to separate 110 volt 60Hz power outlets.
2. Press POWER switch on controller to ON. The indicator above the switch should light. This switch must be on even for the printer to operate.
3. Press STANDBY switch on controller.
4. Set the plotter up for paper/pen operation as instructed in its manual. Paper and pen arrangement are critical.
5. Press plotter POWER switch to ON, PEN & CHART AXIS switches to SLEW.
6. Set PEN switch to DN on plotter and move paper/pen with push buttons on right side of Plotter Control Panel. Make sure that the pen is contacting the paper. This constitutes the check.

7. Repeat step 6 with CHART & PEN AXIS switches set to JOG.
8. Set PEN switch UP on plotter and advance fresh paper.

On-Line Testing

Two sets of punched cards were furnished. Tape one set in an envelope to the controller. From the other set of cards, pull the appropriate time out cards for HASP or 200 UT and insert it into the CYBER 18 controlware deck just ahead of the final card. Load the deck into the system and continue with these ON-LINE tests.

Printer Test

1. Press the controller STANDBY switch.
2. Log-in and call for a print file. The printer should operate and the plotter should not react.

Plotter Test

1. Press the controller OPERATE switch.
2. Set PEN switch to REMOTE and CHART & PEN AXIS switches to PLOT. The READY light on the Plotter should illuminate.
3. The DP-3-1 provides a fixed step size of 0.01.
4. Place the slide switch on the rear of the controller at SLOW position. (A chart on the bottom of the controller shows the relationship of this switch with the above switch.)
5. Insert the provided test card into a job deck and feed the job deck to the CYBER 18. Deck arrangement is:

```
Job,....  
USER(...)  
COP YBR(INP UT,OUTP UT)  
7/8/9  
HI TEST CARD  
6/7/8/9
```

6. The plotter should draw a 1-3/4 inch square. The indicator above the STANDBY/OPERATE switch on the controller should light up while the plotter is receiving data. The printer does not print, but it performs periodic line advances.

SAMPLE CAL906 HARDWARE CONFIGURATION

The following conventions and procedures pertain to the on-line interactive use of the CalComp 1012 Plotter with a 906 interface. This plotter operates with 11-inch fanfold paper and with four pens. It is a desk top unit.

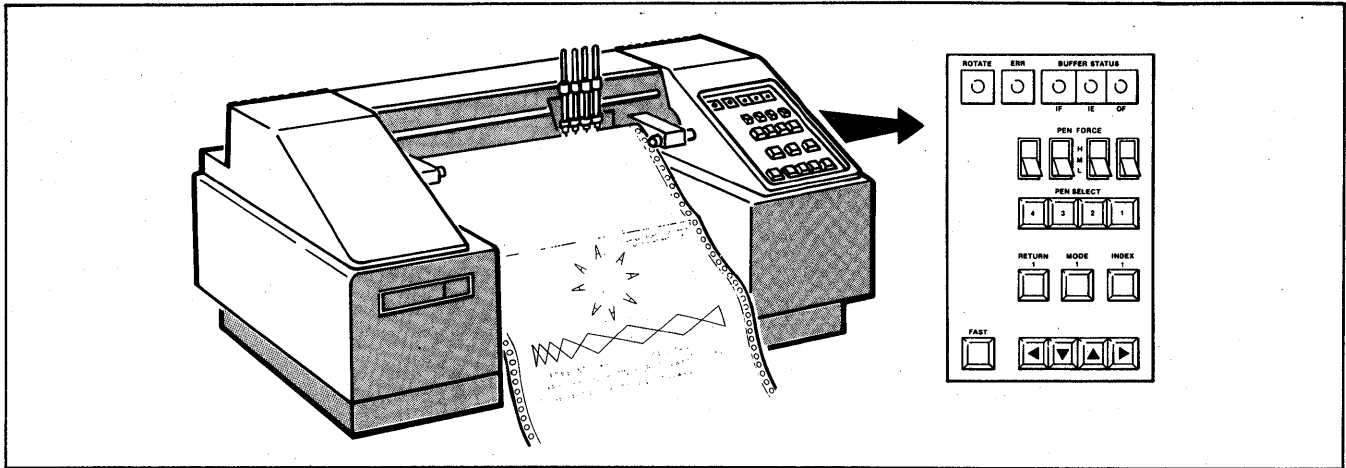

Figure UNIPLLOT V3.1-7. Front View and Control Panel

Connecting the Equipment

1. Disconnect the printer cable from connector 8J01 (on the lower left rear of the printer).
2. Connect that cable to the DATA INPUT connector (see figure UNIPLLOT V3.1-8) on the rear of the plotter.
3. Connect the supplied I/F data communications cable from the TERMINAL connector to connector 8J01 on the printer.

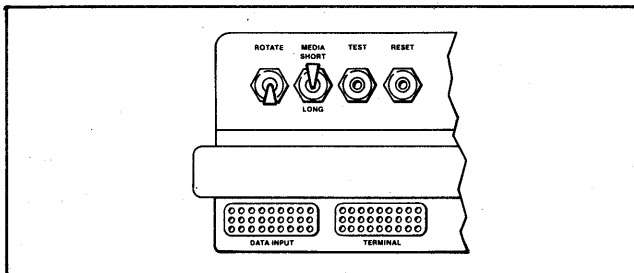

Figure UNIPLLOT V3.1-8. Rear View

Materials Received with Plotter

- 1 - I/F Cable for data communication
- 1 - Pen Kit:
 - 1 - Nut driver
 - 1 - Pen kit case
 - 6 - Nylon tip pens
 - 2 - Nylon tip pen holders
 - 6 - Liquid ball pens
 - 4 - Liquid ball pen holders
- 2 - Operators manuals
- 3 - Packages of paper

Off-Line Testing

1. Connect the power cord of the plotter to a 110 volt 60 Hz outlet.
2. Turn plotter power on with the power switch at the lower left corner.
3. Refer to the plotter manual to set up the pens and paper for operation. Arrangement is critical so follow the instructions carefully.
4. Press the plotter MODE switch (see figure UNIPLLOT V3.1-7). It should flash to indicate "standby" condition.

5. Set the following switches:

- ROTATE (figure UNIPLLOT V3.1-8) = Down; ROTATE indicator (figure UNIPLLOT V3.1-7) should be off to indicate non-rotate mode.
 - MEDIA SHORT/LONG (figure UNIPLLOT V3.1-8) = SHORT; for short paper.
 - PEN FORCE (figure UNIPLLOT V3.1-7) = all at "high" to use liquid ball pens.
 - INDEX (figure UNIPLLOT V3.1-7) = Depress hold until pen 1 is near -x, -y or "home" position.
6. In turn, press each PEN SELECT (figure UNIPLLOT V3.1-7) and several directional arrows for checking pen reaction and movement. Press the FAST switch at least once to check that paper speed picks up.
 7. Perform the self-test as follows (refer to figure UNIPLLOT V3.1-7):
 - a. All pens must be up. Press the appropriate PEN SELECT switch to raise a pen.
 - b. Advance fresh paper by pressing an arrow direction switch.
 - c. Press and hold the INDEX switch to place pen 1 at the "home" position.
 - d. Simultaneously press the RESET and TEST switches (figure UNIPLLOT V3.1-8) and release them, RESET first. The BUFFER STATUS IF indicator should blink and the OF indicator should light.
 - e. Press the MODE switch, it should light to indicate "plot mode." The unit should plot as shown in figure UNIPLLOT V3.1-7.
 8. Press the MODE switch again to place the plotter in "standby mode."
 9. Reverse the ROTATE switch (figure UNIPLLOT V3.1-8). The ROTATE indicator must light.
 10. Repeat steps 7 and 8. The plotted pattern will be turned 90°.
 11. Return the ROTATE switch to its down position. The off-line test is completed.

UNISTRUC II

RELEASE DESCRIPTION

This application comprises the UNISTRUC II interactive finite element modeling pre- and post-processor program and its utilities configured to run under NOS 2 and the NAM/IAF communications package. The full UNISTRUC II system comprises the following programs.

- UNISTRUC - Interactive finite elements modeling pre- and post-processor.
- DIGIT - Interactive structural drawing digitizer.
- UPLOT - UNISTRUC-to-UNIPLOT/UNIPOST interface for offline plotting of UNISTRUC-generated pictures.
- UBULK - Utility to create a UNISTRUC Structural Data Base (SDB) from an existing analysis application input deck.
- NASTIN - UNISTRUC-to-NASTRAN† analysis input translator.
- NASTOUT - NASTRAN†-to-UNISTRUC analysis output translator.
- NBULK - Conversion of NASTRAN† input deck to UBULK input format.
- STARIN - UNISTRUC-to-STAR DYNE†† analysis input translator.
- STAROUT - STAR DYNE††-to-UNISTRUC analysis output translator.
- SBULK - Conversion of STAR DYNE†† input deck to UBULK input format.
- ANSIN - UNISTRUC-to-ANSYS††† analysis input translator.
- ANSOUT - ANSYS†††-to-UNISTRUC analysis output translator.

HARDWARE REQUIREMENTS

The minimum hardware configuration that is required for NOS 2 and the NAM/IAF communications package is required to support UNISTRUC II. Also required are a Tektronix 4006, 4010, 4014, 4016, 4113, or 4114 graphics terminal (or a similar terminal with Tektronix 401x emulation capability) and, if the DIGIT program is used, a digitizing tablet.

†MSC/NASTRAN Version 62.
††Version 3, APR0282 Level.
†††Revision 4.0D2.

COMMUNICATIONS

All limitations applicable to NOS 2 and NAM/IAF also apply to UNISTRUC II.

A CDC synchronous interface (Tektronix product number 021-0135-01) is required on each Tektronix terminal intended to communicate in synchronous mode with the 255x host communications processor on NAM/IAF.

Communications between the terminal and the central site are supported for UNISTRUC II according to table UNISTRUC II-1.

TABLE UNISTRUC II-1. UNISTRUC II Communications Capabilities

Communications Mode	Communications Package	Baud Rates
Synchronous	NAM/IAF	2000,4800,9600
Asynchronous	NAM/IAF	300,1200,2400,4800,9600

TEKTRONIX GRAPHICS TERMINAL SETUP PROCEDURE

The terminal that will be used for the installation and verification of UNISTRUC II must be set up. Instructions for setting up the 4006, 4010, 4014, 4016, 4113, and 4114 Tektronix terminals follow.

TEKTRONIX 4006 TERMINAL

Complete the following to set up the Tektronix 4006 terminal.

1. Turn the terminal power on by turning the POWER switch, located at the rear of the display unit, to the ON position.
2. Allow the terminal to warm up.
3. Press the PAGE key to erase the screen and to position the cursor to home position (the upper left-hand corner of the screen).
4. Select the appropriate transmit and receive baud rates using the baud rate switches located at the rear of the display unit.
5. Set the FULL/HALF DUPLEX switch located at the rear of the display unit (the setting is NOS 2 installation dependent).
6. Turn the modem power on and verify that the modem is connected to the terminal.

TEKTRONIX 4010/4014/4016 TERMINALS WITH SYNCHRONOUS INTERFACE

Complete the following to set up the Tektronix 4010, 4014, and 4016 terminals that are equipped with CDC synchronous interface.

1. Turn the terminal power on.
 - a. Tektronix 4010 terminal: The POWER switch is located beneath the keyboard at the top of the pedestal stand. The red POWER indicator, located at the top of the keyboard, will illuminate when power has been applied to the terminal.
 - b. Tektronix 4014 or 4016 terminal: The POWER switch is located on the front lower right-hand corner of the pedestal stand. The green POWER indicator, located on the upper left-hand corner of the keyboard, will illuminate when power has been applied to the terminal.
2. Allow the terminal to warm up.
3. Press the PAGE key to erase the screen and to position the cursor to home position (the upper left-hand corner of the screen).
4. Set the ASCII/ALT switch to the ASCII position.
5. Select the appropriate baud rate switch settings. The switch should select the EXT position if the terminal is to be used for synchronous communications at 2000, 4800, or 9600 baud. Otherwise, the terminal baud rate switch setting will correspond to the baud rate in use.
 - a. Tektronix 4010 terminal: Select the appropriate transmit and receive baud rates using the baud rate switches located at the rear of the pedestal stand.
 - b. Tektronix 4014 or 4016 terminal: Select the appropriate baud rate using the baud rate switch located at the rear of the pedestal stand.
6. Set the FULL/HALF DUPLEX switch (the setting is NOS 2 installation dependent).

If the Tektronix terminal does not have option 20, the terminal is now operational. If the terminal does have option 20, continue with step 7.

7. Set the CODE EXPANDER switch to one of the following positions.
 - a. Synchronous mode communications: Turn the switch ON.
 - b. Asynchronous mode communications: Turn the switch OFF.

8. Establish proper operating mode with the following keyboard operations.

- a. Synchronous mode communications: Place the terminal in local mode. Press the SHIFT key. While the SHIFT key is pressed, press the RESET PAGE key. Place the terminal in line mode.
- b. Asynchronous mode communications: Place the terminal in local mode. Press SHIFT key. While the SHIFT key is pressed, press the RESET PAGE key.

Next, while both the SHIFT and CNTL keys are pressed, press the P key. Place the terminal in line mode.

The terminal is now operational.

TEKTRONIX 4010/4014/4016 TERMINALS WITHOUT SYNCHRONOUS INTERFACE

If the Tektronix 4010, 4014, and 4016 terminals are not equipped with the CDC synchronous interface option, then the terminal can be operated in asynchronous mode only.

The Tektronix 4010, 4014, and 4016 terminals asynchronous mode operating procedures are essentially the same as for the synchronous mode operating procedures. However, step 8 of the synchronous mode operating procedures can be omitted. No special keyboard operations are required to establish mode switching since the terminals will always be in asynchronous mode when not equipped with the CDC synchronous interface option.

TEKTRONIX 4113/4114 TERMINALS

Complete the following steps to set up the Tektronix 4113 and 4114 terminals.

1. Turn the terminal power on by pushing the POWER button, which is located above the keyboard on the base pedestal.
2. Allow the terminal to initialize (some keys on the keyboard remain lit until the terminal has completed its initialization).
3. Press the SET UP key so that the terminal operating modes can be changed at the keyboard. An asterisk (*) should appear to the left of the cursor.
4. Select the appropriate baud rate by entering:
BAUD number
number is the desired baud rate. It can range from 300 through 9600.
5. Enter STA BAUD to verify the baud rate entry.
6. Press the SET UP key to complete the process.

RELEASE MATERIALS

The UNISTRUC system of programs is contained on the tape referred to as REL75. REL75 has the following characteristics: 7-track with 800 characters per inch (cpi) or 9-track with either 800 or 1600 cpi, binary recording mode, and data format is internal with a HDR1 label containing a file ID of UNISTRUCH15OCT82.

REL75 comprises the following files.

File 1 - Procedures for the following tasks: loading the contents of REL75 onto the target installation machine and generating the installation machine dependent procedure files UNISTRUC, WLMODEL, and VRFPROC,

File 2 - UNIPF, UNISTRUC Installation Parameters File which contains default execution parameters that may be later tailored to the given site,

Files 3 through 8 - WLBDATA, binary data files from the wheel model example in the UNISTRUC II User's Guide,

WLSDB The complete wheel model SDB after UNISTRUC post-processing

WLUT1 The NASTRAN UT1 auxiliary output file for the wheel

WLPLOT The wheel PLOT file from #PLOT in UNISTRUC

WLNPFIL The wheel NPFILE from UPLOT in inch units

WLNPFILCM The wheel NPFILE from UPLOT in centimeter units

WLTAPE12 The ANSYS TAPE12 auxiliary output file for the wheel

Files 9 through 28 - WLCDATA, card image data files from the wheel model example in the UNISTRUC II User's Guide,

WLNID Neutral Input Data file for the wheel model (3 files)

WLAIDN The NASTRAN Application Input Data for the wheel

WLAIDS The STARDYNE Application Input Data for the wheel

WLAIDA The ANSYS Application Input Data for the wheel

WLTAPE4 The STARDYNE TAPE4 Auxiliary output file for the wheel (2 files)

WLNODN The wheel Neutral Output Data file from NASTOUT (2 files)

WLNODS The wheel Neutral Output Data file from STAROUT (2 files)

WLUBDN The wheel UBULK Data file from NBULK (2 files)

WLUBDS The wheel UBULK Data file from SBULK (2 files)

WLPRESC The wheel model preprocessing user input script up through NID creation in UNISTRUC

WLPSTSC The wheel model post-processing user input script which reads NOD in UNISTRUC

WLNODA The wheel Neutral Output Data file from ANSOUT (2 files)

File 29 - UNISTRUC, absolute binaries for the interactive program UNISTRUC,

Files 30 and 31 - printed output for UNISTRUC installation verification,

File 32 - DIGIT, absolute binaries for the interactive program DIGIT,

Files 33 and 34 - printed output for DIGIT installation verification,

File 35 - UBULK, absolute binaries for the batch program UBULK,

Files 36 and 37 - printed output for UBULK installation verification,

File 38 - UPLOTIN, absolute binaries for the inch version of the batch program UPLOT,

File 39 - UPLOTICM, absolute binaries for the metric version of the batch program UPLOT,

Files 40 and 41 - printed output for UPLOT installation verification,

File 42 - NASTIN, absolute binaries for the batch program NASTIN,

Files 43 and 44 - printed output for NASTIN installation verification,

File 45 - NASTOUT, absolute binaries for the batch program NASTOUT,

Files 46 and 47 - printed output for NASTOUT installation verification,

File 48 - NBULK, absolute binaries for the batch program NBULK,

- Files 49 - printed output for NBULK installation and 50 verification,
- File 51 - STARIN, absolute binaries for the batch program STARIN,
- Files 52 - printed output for STARIN installation and 53 verification,
- File 54 - STAROUT, absolute binaries for the batch program STAROUT,
- Files 55 - printed output for STAROUT installation and 56 verification,
- File 57 - SBULK, absolute binaries for the batch program SBULK,
- Files 58 - printed output for SBULK installation and 59 verification,
- File 60 - ANSIN, absolute binaries for the batch program ANSIN,
- Files 61 - printed output for ANSIN installation and 62 verification,
- File 63 - ANSOUT, absolute binaries for the batch program ANSOUT, and
- Files 64 - printed output for ANSOUT installation and 65 verification.

Printer output from the installation job includes information to be used in verifying a correct installation. For each program installed, the following verification information is printed:

- A banner indicating the program for which this information is provided.
- A copy of the verification procedure for the program.
- A copy of an itemize of the program absolute binaries run when the program was originally created and verified.
- An output listing from the program that is used as a verification reference by the verification procedure when verification is performed at the installation site. (For UNISTRUC and DIGIT, the verification outputs are displays at the graphics terminal screen). The verification output printed for UPLOT is invalid, and should be ignored.

After the UNISTRUC installation parameter file (UNIIPF) is installed, it should be modified to reflect the correct parameters for the site of installation. (Refer to UNISTRUC II Installation Parameter File On-Site Maintenance in this section.)

All programs and procedures in the UNISTRUC II system are set up to be installed under and accessible from user name APPLLIB. To install the UNISTRUC II, the following job must be run from the system console.

INSTALLATION PROCEDURES

This document discusses the installation of all programs in the UNISTRUC II system.

Ensure that no permanent files exist with the same names as the files generated in the installation procedure because they will be purged and replaced by the following permanent files generated during installation and verification: RDREL75, UNIIPF, UNISTRUC, WLMODEL, VRFPROC, WLBDATA, WLCDATA, UNISTRUC, DIGIT, UBULK, UPLOTIN, UPLOTIN, NASTIN, NASTOUT, NBULK, STARIN, STAROUT, SBULK, ANSIN, ANSOUT, WHLSDB, WHLNID, TOWER, and LINE.

```
X.DIS.
SUI,377774.
LABEL,REL75,L=UNISTRUCII15OCT82,D= { HY
                                     HD },
                                     PE }
VSN=REL75A.
REWIND,REL75.
COPYBF,REL75,RDREL75.
VERIFY,REL75,RDREL75,N=1,R,A.
BEGIN,RDREL75,RDREL75,IUN=APPLLIB.
```

In a full installation of the complete UNISTRUC II system when the above installation job has completed execution, the permanent files listed in table UNISTRUC II-2 should appear on UN=APPLLIB.

TABLE UNISTRUC II-2. UNISTRUC II PERMANENT FILES

Permanent File Name	Access Type	Category (CT)	Mode (M)	Password	Contents
UNISTRUC	INDIR	PU	R	None	Procedures for executing all programs
UNIPPF	INDIR	PU	R	None	Installation parameter file
UNISTRU	DIR	PU	R	None	UNISTRUC absolute binaries
DIGIT	DIR	PU	R	None	DIGIT absolute binaries
UBULK	DIR	PU	R	None	UBULK absolute binaries
UPLOTIN	DIR	PU	R	None	UPLOT absolute binaries for inch units
UPLOTCM	DIR	PU	R	None	UPLOT absolute binaries for centimeter units
NASTIN	DIR	PU	R	None	NASTIN absolute binaries
NASTOUT	DIR	PU	R	None	NASTOUT absolute binaries
NBULK	DIR	PU	R	None	NBULK absolute binaries
STARIN	DIR	PU	R	None	STARIN absolute binaries
STAROUT	DIR	PU	R	None	STAROUT absolute binaries
SBULK	DIR	PU	R	None	SBULK absolute binaries
ANSIN	DIR	PU	R	None	ANSIN absolute binaries
ANSOUT	DIR	PU	R	None	ANSOUT absolute binaries
WLMODEL	INDIR	PU	R	None	Procedures for accessing data on files WLBDATA and WLCDATA
WLBDATA	DIR	PU	R	None	Wheel model binary data
WLCDATA	DIR	PU	R	None	Wheel model card image data
VRFPROC	INDIR	PU	R	None	Verification procedures
RDREL75	INDIR	PU	R	None	Installation procedure

VERIFICATION PROCEDURE

Once the UNISTRUC II programs are installed and the installation job output listing is available, the installation verification testing may begin.

Execution of verification tests for the programs installed may be run using the VRFPROC procedures file stored on the machine during the installation run. VRFPROC contains a test procedure for each program installed. These procedures are the same as those printed out for each program as part of the installation OUTPUT listings. This section describes usage of these verification procedures.

As an alternative to the automated verification, the installer may test installation of the system manually by executing jobs which duplicate the verification procedures listed for each program as shown in the installation output listing (UNISTRUC and DIGIT must be run interactively).

Verification tests use wheel model data from the WLBDATA and WLCDATA files for comparison in determining correct execution of the programs. This data is used both as input to the programs and results comparison after the program is run.

UNISTRUC VERIFICATION

Verification of the UNISTRUC program installation must be performed interactively from the graphics terminal. A script of input for the wheel model from the UNISTRUC User's Guide is executed.

First, obtain an explanation of the UNISTRUC program verification by entering at the terminal:

```
GET,VRFPROC/UN=APPLLIB.  
BEGIN,VRUNLJB,VRFPROC,MODE=EXPLAIN.
```

The explanation will be printed on the terminal screen as shown in figure UNISTRUC II-1. An itemize listing of UNISTRUC is also created with local file name UNITEM. This file should be routed to the printer for comparison with the itemize printed at installation time.

The next step is to set up the program and test files required for the verification test by entering at the terminal:

```
BEGIN,VRUNIJB,VRFPROC,MODE=SETUP.
```

When the setup is complete, a message will appear at the screen as in figure UNISTRUC II-2 describing the UNISTRUC input which the user must enter to initiate the script reading process. UNISTRUC will prompt the user for the input after the user enters at the terminal:

```
BEGIN,VRUNIJB,VRFPROC,MODE=RUN.
```

The UNISTRUC program verification test takes about 10 minutes wall-clock time to run and creates SDB and NID permanent files for the wheel model with permanent file names WHLSDB and WHLNID, respectively. Several pictures will be created at the terminal screen and automatically clear as the script is run.

When the UNISTRUC script run is complete, the final screen will appear as in figure UNISTRUC II-3. The verification of the NID file creation may then be tested by entering at the terminal:

```
BEGIN,VRUNIJB,VRFPROC,MODE=VERIFY.
```

The first file of the WLNID file (from the WLCDATA permanent file) and the first file of the NID file created by the script run above are copied to the screen for visual comparison, since the creation DATE and TIME stamps will not match. The remaining data is automatically compared using the NOS VERIFY utility as shown in figure UNISTRUC II-4.

```
BEGIN,VRUNIB,VRFPROC,MODE=EXPLAIN
```

THE UNISTRUC VERIFY CCL PROCEDURE IS AN INTERACTIVE PROCEDURE WHICH MUST BE RUN FROM A GRAPHICS TERMINAL. THE UNISTRUC VERIFY SESSION REPRODUCES THE WHEEL MODEL EXAMPLE PROBLEM DOCUMENTED IN THE UNISTRUC II USER'S GUIDE. WHEN THE VERIFY PROCEDURE IS RUN THE USER ENTERS ONLY A SINGLE COMMAND AT THE BEGINNING OF THE VERIFY RUN AND UNISTRUC WILL READ THE REMAINING INPUT FROM A SCRIPT FILE AND ECHO IT TO THE SCREEN AS INPUT DIALOG. THE VERIFY RUNS ABOUT 10 MINUTES (WALL CLOCK TIME) AND PRODUCES THE WHEEL SDB AND NID FILES.

AN ITEMIZE HAS BEEN CREATED BY THIS PROCEDURE EXECUTION, WITH OUTPUT ON LOCAL FILE NAME UNITEM. SEND UNITEM TO PRINT FOR COMPARISON WITH UNISTRUC ITEMIZE PROVIDED WITH THE INSTALLATION FILES.

TO SET UP FOR THE VERIFY RUN ENTER-

```
BEGIN,VRUNIB,VRFPROC,MODE=SETUP
```

READY.

ROUTE,UNITEM, DC=LP,UN.

READY.

Figure UNISTRUC II-1. UNISTRUC Verification "EXPLAIN"

```
/BEGIN,VRUNIB,VRFPROC,MODE=SETUP
```

THE UNISTRUC WHEEL MODEL IS NOW READY TO RUN. UNISTRUC WILL PROMPT THE USER FOR TERMINAL TYPE AND BAUD RATE. IN ORDER TO RUN THE WHEEL SCRIPT THE USER SHOULD RESPOND TO THE TERMINAL TYPE PROMPT WITH THE FOLLOWING INPUT-

NUM SCRIN A

WHERE-

NUM - IS A VALID TERMINAL TYPE NUMBER (1-11), IF NOT KNOWN ENTER- L ONLY AND A CARRIAGE RETURN AND UNISTRUC WILL LIST THE NUMBERS.

SCRIN - IS THE UNISTRUC KEYWORD TELLING THE PROGRAM TO READ THE REMAINING INPUT FROM LOCAL FILE SCRIPT.

A - IS THE UNISTRUC KEYWORD TELLING THE PROGRAM TO READ THE SCRIPT AUTOMATICALLY WITHOUT PAUSING, UNTIL THE SCRIPT IS EXHAUSTED.

TO BEGIN THIS PORTION OF THE VERIFY ENTER-
BEGIN,VRUNIB,VRFPROC,MODE=RUN.

REVERT. VRFPROC

/

```
BEGIN,VRUNIB,VRFPROC,MODE=RUN
```

```
ENTER TERMINAL TYPE(L)
```

```
? 5 SCRIN A
```

```
ENTER BAUD RATE(L)
```

```
? 1200
```

Figure UNISTRUC II-2. UNISTRUC Verification "SETUP" and "RUN"

```

++++++ COMMAND SYNTAX ++++++
0=0 -NEUTRAL OUTPUT ONLY
0=1 -APPLICATION OUTPUT ONLY
0=2 *BOTH OUTPUTS
D=0 -NO DISPLACEMENTS
D=1 *DISPLACEMENTS
S=0 -NO STRESSES
S=1 *STRESSES
R=0 -NO RESTRAINT FORCES
R=1 *RESTRAINT FORCES
CHECKRUN - CHECKRUN FLAG
DI -DISPLAY INPUT
RJ -REJECT INPUT
EXIT -EXIT TO MENU
// -PROCESS CMD
++++++ END OF LIST ++++++

```

WHEEL(1/4 SECTION) - UNISTRUC MODEL

81/10/09
07.31.37

```

..//
*I*CREATING NEUTRAL INPUT FILE
NEUTRAL INPUT GENERATED
      81/10/09.      07.31.34
TITLE      WHEEL(1/4 SECTION) - UNISTRUC MODEL DEMONSTRATION
BLOCKS      2      3      4      5      6
LOAD SETS      SCALE FACTORS , LOAD CASES
      1      .100000E+01      1

```

```

--- APPLICATION INPUT MENU ---
1 RETURN - MASTER
2 DISPLAY
3 CREATE NEUTRAL INPUT FILE
4 BANDWIDTH MINIMIZATION
5 PROFILE MINIMIZATION
6 QUICK OPTIMIZATION
7 OPT NODE NUMBER DISPLAY
SELECT: APPLICATION INPUT MENU

```

```

..RET
--- MASTER          MENU ---
1 TERMINATE
2 MESH
3 PROPERTIES
4 BOUNDARY CONDITIONS
5 APPLICATION INPUT
6 RESULT REVIEW
7 MISCELLANEOUS FUNCTIONS
SELECT: MASTER     MENU
..TERM

```

```

+UNISTRUC UTILIZATION SUMMARY+
SINCE      81/10/09 81/10/09
           07.29.29 07.23.32
USAGE - HRS      .04      .14

```

```

LAST CHECKPOINT MADE TO PFN OF
WHLSDB
PREPARING TO CHECKPOINT SDB.
ENTER CHECKPOINT CMD(L,*,//)
..//
SDB SUCCESSFULLY CHECKPOINTED
PFN = WHLSDB

```

A WHEEL SDB AND NID FILE SHOULD NOW EXIST. TO RUN THE VERIFY COMPARISON BETWEEN THE NID JUST CREATED AND THE WLMODEL NID PROVIDED WITH THE WLMODEL DATA, THE USER SHOULD CLEAR THE SCREEN AND ENTER-

BEGIN,VRUNIBJ,VRFPROC,MODE=VERIFY

REVERT. VRUNLJB

Figure UNISTRUC II-3. UNISTRUC Verification Final Screen Picture on a Tektronix 4014 Terminal

```

/BEGIN,VRUNIJB,VRFPROC,MODE=VERIFY
1N-INPUT 80/09/26. 21.13.23.
  BLOCK 5
    2 3 4 5 6
  LOAD 1
1N-INPUT 80/12/17. 14.33.50.
  BLOCK 5
    2 3 4 5 6
  LOAD 1

```

1

THE UNISTRUC VERIFICATION PROCESS IS NOW COMPLETE.

```

REVERT. VRFPROC
/DAYFILE,OUTPUT,$VERIFY,WLNID$
14.46.30.VERIFY,WLNID,NID,N=2.
14.46.30.VERIFY GOOD.
14.46.30.COPYSBF,VRMSGs.
14.46.31. EOI ENCOUNTERED.
14.46.31.RETURN,VRMSGs.
14.46.31.ENDIF,VRF1.
14.46.31.RETURN,UNISTRUC,WLMODEL.
14.46.31REVERT. VRFPROC
14.47.23.$DAYFILE,OUTPUT,$VERIFY,WLNID$.
USER DAYFILE DUMPED.

```

Figure UNISTRUC II-4. UNISTRUC NID Creation "VERIFY"

DIGIT VERIFICATION

Verification of the DIGIT program installation must be done interactively at the graphics terminal using the digitizing tablet. This test uses the example digitizing session shown in the UNISTRUC Reference Manual (appendix C).

First, obtain an explanation of the DIGIT program verification by entering at the terminal:

```

GET,VRFPROC/UN=APLLIB.
BEGIN,VRDIGJB,VRFPROC,MODE=EXPLAIN.

```

The explanation will be printed on the terminal screen as shown in figure UNISTRUC II-5. An itemize listing of DIGIT is also created with the local file name DIGITEM. This file should be routed to the printer for comparison with the itemize printed at installation time.

The next step is to set up the program files required for the verification test by entering at the terminal:

```

BEGIN,VRDIGJB,VRFPROC,MODE=SETUP.

```

When the setup is complete, a message will appear on the screen, as in figure UNISTRUC II-6, describing the input the user must enter to run the test. The installer should tape one of the example model plan views from the UNISTRUC Reference Manual to the tablet surface and set up the terminal for digitizing (see hardware requirements in appendix C of the reference manual). When everything is ready, the installer should enter at the terminal:

```

BEGIN,VRDIGJB,VRFPROC,MODE=RUN.

```

There is no script for the DIGIT verification since the installer must interact with the program to perform the digitizing. The installer should follow the steps shown for the example session in appendix C of the UNISTRUC Reference Manual. When this session is complete, a message will appear at the terminal as in figure UNISTRUC II-7 instructing the installer to list the LINE file just created and compare it to the LINE file from the example session in the reference manual.

UTILITY PROGRAMS VERIFICATION

All other programs in the UNISTRUC system may be verified in deferred batch jobs or from the graphics terminal. If run from the graphics terminal, the file OUTPUT should be assigned to mass storage as a great deal of data will be printed out. To assign output to mass storage, enter at the terminal:

```

ASSIGN,MS,OUTPUT.

```

The following job may be submitted to execute the verification of all other programs installed.

<u>JOB</u>	<u>PROGRAM VERIFIED</u>
VERIFY,T0.	
USER,username,password,familyname.	
CHARGE,*.	
GET,VRFPROC/UN=APLLIB.	
BEGIN,VRUBKJB,VRFPROC.	UBULK
BEGIN,VRUPTJB,VRFPROC.	UPLLOT (inch)
BEGIN,VRUPTJB,VRFPROC,	
NPFIL=METRIC.	UPLLOT (centimetre)
BEGIN,VRNAIJB,VRFPROC.	NASTIN
BEGIN,VRNAOJB,VRFPROC.	NASTOUT
BEGIN,VRNBKJB,VRFPROC.	NBULK
BEGIN,VRSTIJB,VRFPROC.	STARIN
BEGIN,VRSTOJB,VRFPROC.	STAROUT
BEGIN,VRSBKJB,VRFPROC.	SBULK
BEGIN,VRANIJB,VRFPROC.	ANSIN
BEGIN,VRANOJB,VRFPROC.	ANSOUT
DAYFILE.	
(dispose OUTPUT to printer)	
--eoi--	

In the preceding NASTIN verify test job, for example, VRFPROC runs the WLMODEL procedure to get a copy of the wheel model NID file (WLNID) from the WLCDATA file. This NID is then used as input to NASTIN which creates an AID file for NASTRAN. The WLMODEL procedure is then again used to get a copy of the wheel AID file for NASTRAN (WLAIN) and the two files are compared. The other programs are verified in similar fashion.

```
/BEGIN,VRDIGJB,VRFPROC,MODE=EXPLAIN
THIS DIGIT VERIFY PROCEDURE IS AN INTERACTIVE PROCEDURE WHICH MUST BE RUN FROM A
GRAPHICS TERMINAL.
```

THIS DIGIT VERIFY SESSION REQUESTS THE TESTER TO REPRODUCE THE STEPS OF THE DIGIT EXAMPLE MODEL SHOWN IN THE UNISTRUC REFERENCE MANUAL. THE TESTER SHOULD TAKE ONE OF THE MODEL PLAN VIEWS FROM THE REFERENCE MANUAL, MOUNT IT ON THE DIGITIZING SURFACE, AND DIGITIZE IT FOLLOWING THE STEPS IN THE REFERENCE MANUAL.

THIS VRDIGJB EXECUTION HAS ALSO CREATED AN ITEMIZE OF DIGIT ON A LOCAL FILE NAME DIGITEM. THE TESTER SHOULD SEND IT TO PRINT AND COMPARE IT TO THE ITEMIZE OF DIGIT PROVIDED WITH THE INSTALLATION MATERIALS.

TO SET UP THE DIGIT VERIFY RUN ENTER-

```
BEGIN,VRDIGJB,VRFPROC,MODE=SETUP.
```

```
REVERT. VRFPROC
/STATUS,F
```

LOCAL FILE INFORMATION.

FILENAME	LENGTH/PRUS	TYPE	STATUS
INPUT*		IN.*	EOR READ
VRFPROC	25	LO.	EOR READ
ZZZZC1	2	LO.	EOR READ
OUTPUT		LO.	I/C READ
ZZZZC2	1	LO.	EOR READ
DIGITEM	9	LO.	EOR WRITE

```
TOTAL = 6
/ROUTE,DIGITEM,DC=LP,UN
ROUTE COMPLETE
/
```

Figure UNISTRUC II-5. DIGIT Verification "EXPLAIN"

```
/BEGIN,VRDIGJB,VRFPROC,MODE=SETUP
```

THE DIGIT VERIFY IS NOW READY TO RUN, THE TESTER SHOULD HAVE ONE OF THE DIGIT EXAMPLE MODEL PLAN VIEWS ON THE DIGITIZING SURFACE AND BE READY TO FOLLOW THE STEPS OUTLINED IN THE EXAMPLE

TO BEGIN THIS PORTION OF THE VERIFY ENTER-

```
BEGIN,VRDIGJB,VRFPROC,MODE=RUN.
```

```
REVERT. VRFPROC
/BEGIN,VRDIGJB,VRFPROC,MODE=RUN.
ENTER TERMINAL TYPE(L)
```

```
? 5
ENTER BAUD RATE(L)
```

```
? 1200
ENTER TABLET TYPE(L)
```

```
? 2
```

Figure UNISTRUC II-6. DIGIT Verification "SETUP" and "RUN"

THE TESTER SHOULD NOW HAVE A PERMANENTLY SAVED LINE FILE CREATED. THE TESTER SHOULD ATTACH IT TO THE TERMINAL, COPY IT TO THE SCREEN AND COMPARE THE COORDINATE DATA TO THE LINE DATA FILE SHOWN IN THE EXAMPLE PROBLEM. THE COORDINATE DATA SHOULD COMPARE WITHIN A REASONABLE MARGIN OF DIGITIZING ACCURACY.

THE DIGIT VERIFY PROCESS SHOULD THEN BE COMPLETE.

```
REVERT. VRFPROC
/
```

Figure UNISTRUC II-7. DIGIT Verification "VERIFY"

U PLOT VERIFICATION OPTIONS

The U PLOT verification has two options, one for inch unit plotters and one for metric unit plotters. The installer may wish to plot and visually compare the N PFILE's created by U PLOT. In order to do this, the N PFILE and WLN PFILE must be routed to the proper plotting destination after each VRUPTJB procedure is run. The plots created should look like figure UNISTRUC II-8.

The dayfiles from these procedures should show a VERIFY GOOD from the NOS VERIFY utility for all tests except the N PFILE verify. The N PFILE has a creation date and time stamp which will not match, which is still acceptable. For example, the VERIFY ERRORS shown in octal format in figure UNISTRUC II-9 have the alpha representations of:

<u>N PFILE</u>	<u>WLN PFILE</u>
82/10/19.	82/10/18.
11.23.16.	14.18.55.

These should be the only "errors" from U PLOT verification. Ignore the sample U PLOT verification which was printed at installation time.

VERIFICATION COMPLETION

Following the verification of a successful installation, the installation procedure file, RDREL75, and the verification procedure file, VRFPROC, may be eliminated as permanent files. The wheel example model files

WLMODEL, WLB DATA, and WLC DATA may be either retained for demonstration purposes or purged as required.

Data on these files may be accessed by the WLMODEL procedure by entering:

```
GET,WLMODEL/UN=APPLLIB.  
BEGIN,WLMODEL,WLMODEL,name,ifn.
```

name is the name of the data file to be copied from the WLB DATA or WLC DATA permanent file. Refer to WLB DATA and WLC DATA in Release Materials in this section for a list of data file names.

ifn is an optional local file to receive the data file. If ifn is not entered, name will be the local file name to receive the data. The receiving file is rewound before and after the copying.

UNISTRUC II AND UTILITY EXECUTION PROCEDURE

The programs of the UNISTRUC system as accessed for execution via the BEGIN procedures provided on the installation tape. To execute a program of the UNISTRUC system, get procedure file UNISTRUC, which is cataloged under the user name APPLLIB. Then enter the appropriate BEGIN command for the selected program; refer to the UNISTRUC Reference Manual for descriptions of the BEGIN command formats.

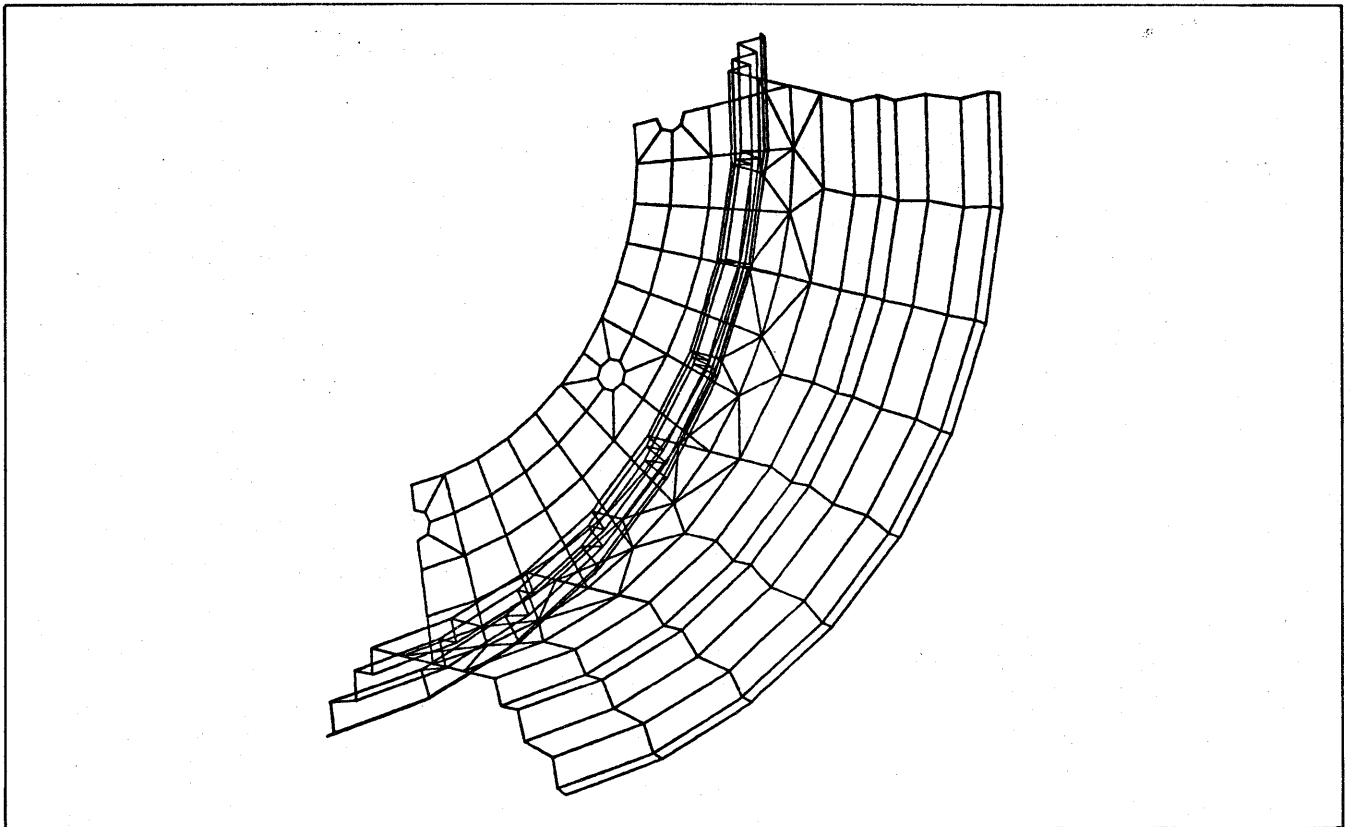

Figure UNISTRUC II-8. U PLOT Offline Plot

RECORD	WORD (OCTAL)	DATA FROM NPFILE	FILE	1	82/10/19.	11/23/36	PAGE	1
		DATA FROM WLNPFIL			LOGICAL DIFFERENCE			
RECORD TYPE		COS/NPF V3.		COS/NPF V3.				
1	20	55433 55034 33503 44457	55433	55034	33503	44357	00000	00000 00000 00700
1	21	55343 45735 36573 44157	55343	74734	43574	04057	00000	30001 75007 40100

VERIFY ERROR LIST. 82/10/19. 11.23.36. PAGE 2

***** 0 RECORD(S) IN EXCESS FILE 2 ON WLNPFIL

Figure UNISTRUC II-9. UPLOTT Verification "Verify Errors"

OVERVIEW OF UNISTRUC II PROGRAMS/FILES

Programs communicate with each other and with programs outside the UNISTRUC system via the following files:

- UNIPF - Installation parameter file
- SDB - Structural data base
- NID - Neutral input data file
- ULOG - Log file
- SCRIPT - Script input file
- AID - Application input data file (NASTRAN, STARDYNE, ANSYS)
- UT1 - NASTRAN analysis output file
- TAPE4 - STARDYNE analysis output file
- TAPE12 - ANSYS analysis output file
- NOD - Neutral output data file
- ABD - Application bulk data file
- UBD - UNISTRUC bulk data file
- LINE - Line geometry file
- PFILE - Point coordinate file
- PLOT - Offline picture plotting file
- NPFILE - UNIPLOT neutral plot file

Specific formats for the NID, NOD, UBD, and LINE files are given in the UNISTRUC Reference Manual. The files may be used by a user program via READ statements or created via formatted WRITE statements.

Figures UNISTRUC II-10 through UNISTRUC II-14 illustrate the relationships of the various programs and files of the UNISTRUC system. (CD/2000 is not part of the UNISTRUC system, but can generate a UNISTRUC LINE file.)

The procedures for executing the programs of the UNISTRUC system are given in the UNISTRUC Reference Manual.

UNISTRUC II INSTALLATION PARAMETER FILE ON-SITE MAINTENANCE

The UNISTRUC installation parameter file, UNIPF, in card-image format contains various information peculiar to the place of installation. The file is generated automatically by the installation procedures. A description of this file follows the description of the card-image formats.

The first two card-images on the UNIPF file installed (not shown here) are internal UNISTRUC information and should not be changed. The following card-images may be in any

order. Each card-image contains a keyword beginning in column 1 followed by the corresponding item of data beginning in column 11. Integers are right justified in the respective fields. Card-image format is expressed using FORMAT specifications of FORTRAN.

Card-Image Format	Keyword	Possible Values and Their Explanations
(A10,I2)	TERM	Terminal types 0 - Installation has more than one terminal type. UNISTRUC prompts the user to enter an appropriate type. This is the default value. 1 - Tektronix 4006, asynchronous mode. 2 - Tektronix 4010, synchronous mode. 3 - Tektronix 4010, asynchronous mode. 4 - Tektronix 4014, synchronous mode. 5 - Tektronix 4014, asynchronous mode. 6 - Tektronix 4014 with enhanced graphics module (EGM), synchronous mode. 7 - Tektronix 4014 with EGM, asynchronous mode. 8 - Tektronix 4016 with EGM, synchronous mode. 9 - Tektronix 4016 with EGM, asynchronous mode. 10 - Tektronix 4114 with EGM, asynchronous mode. 11 - Tektronix 4113, asynchronous mode.
(A10,I4)	ABAUD	Baud rate for asynchronous communications 0 - Installation has more than one baud rate. UNISTRUC prompts the user to enter an appropriate baud rate. This is the default value. 300 - 300 baud 1200 - 1200 baud 2400 - 2400 baud 4800 - 4800 baud 9600 - 9600 baud

Card-Image Format	Keyword	Possible Values and Their Explanations
(A10,I4)	SBAUD	Baud rate for synchronous communications 0 - Installation has more than one baud rate. UNISTRUC prompts the user to enter an appropriate baud rate. This is the default value. 2000 - 2000 baud 2400 - 2400 baud 4800 - 4800 baud 9600 - 9600 baud

(A10,I1) TABLET Tablet type
1 - Tablet not needed.

(A10,3A10) SUPNAM Local UNISTRUC support analyst name displayed as part of recovery messages. Default is blanks.

(A10,3A10) SUPNUM Local UNISTRUC support analyst phone number displayed as part of recovery messages. Default is blanks.

The UNIPF file provided with the release materials has the following settings:

Keyword	Value
TERM	0
ABAUD	0
SBAUD	0
TABLET	1
SUPNAM	—UNISTRUC SUPPORT ANALYST—
SUPNUM	—ANALYST TELEPHONE NUMBER—

The UNIPF card-images previously described may be modified at the installation site to reflect the environments of that site. If the TERM, ABAUD, and/or SBAUD keywords are set to the appropriate nonzero values, UNISTRUC does not prompt the user for this information at the beginning of each session. For example, if the only asynchronous communication the site supports is 1200 baud, change the value of ABAUD to 1200 and no prompt will appear for the asynchronous baud rate. Also, be sure to change the values of SUPNAM and SUPNUM to the name and telephone number of the local analyst responsible for UNISTRUC customer support (hotline).

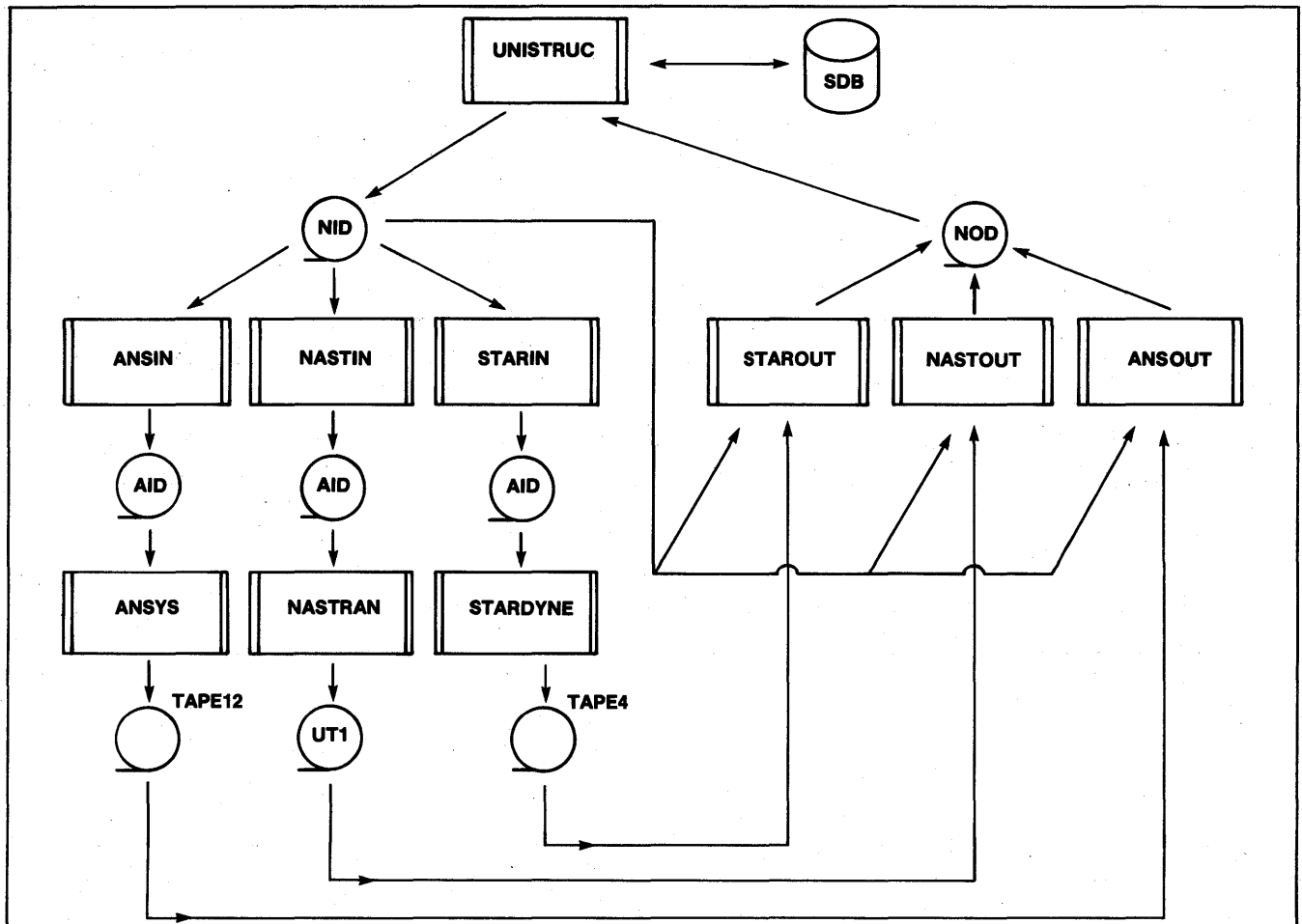

Figure UNISTRUC II-10. UNISTRUC and Application Translators

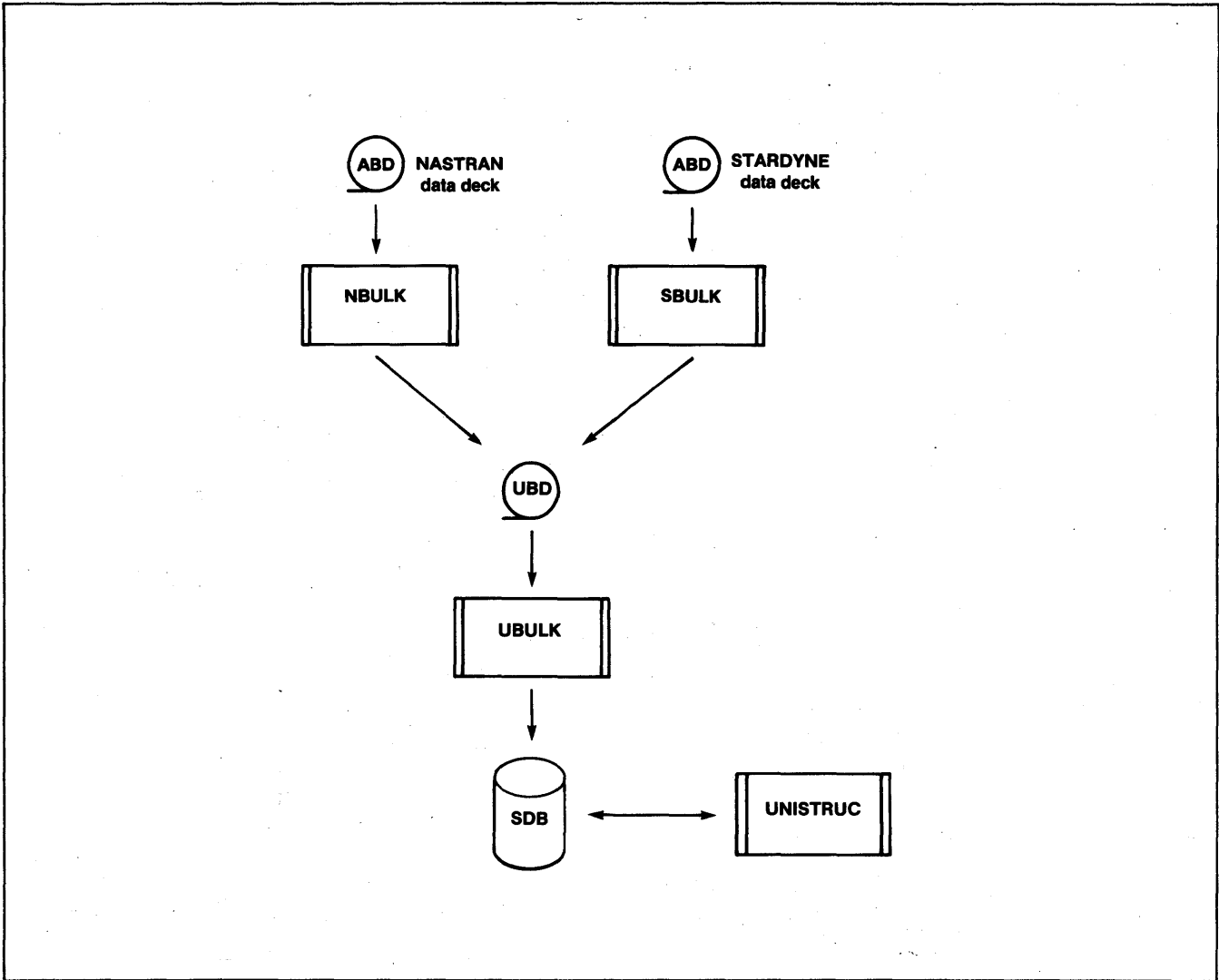

Figure UNISTRUC II-11. Bulk Data Translators

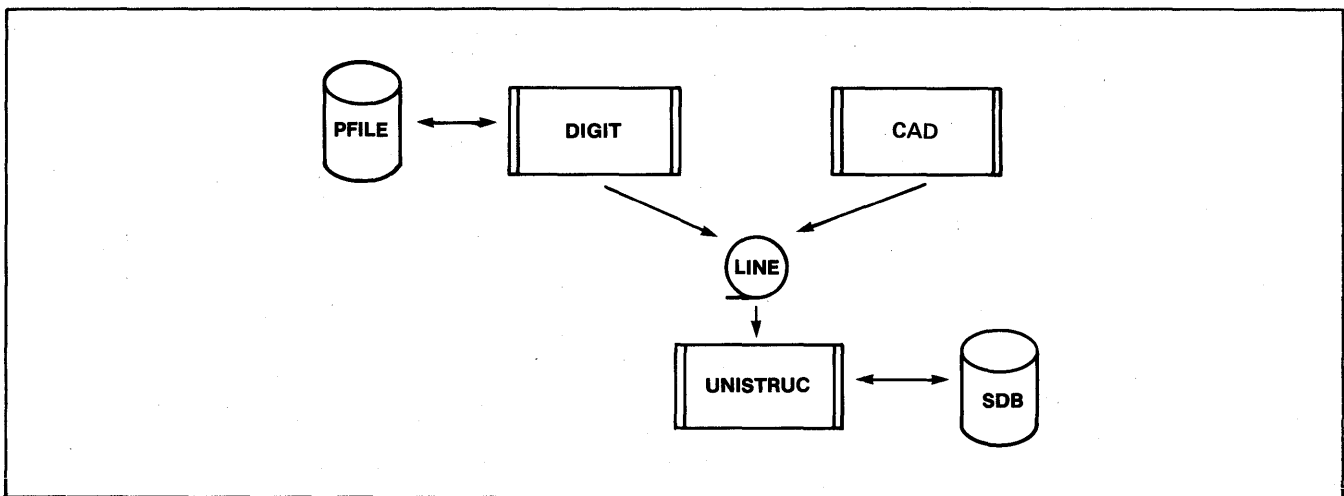

Figure UNISTRUC II-12. UNISTRUC CAD Data Interface

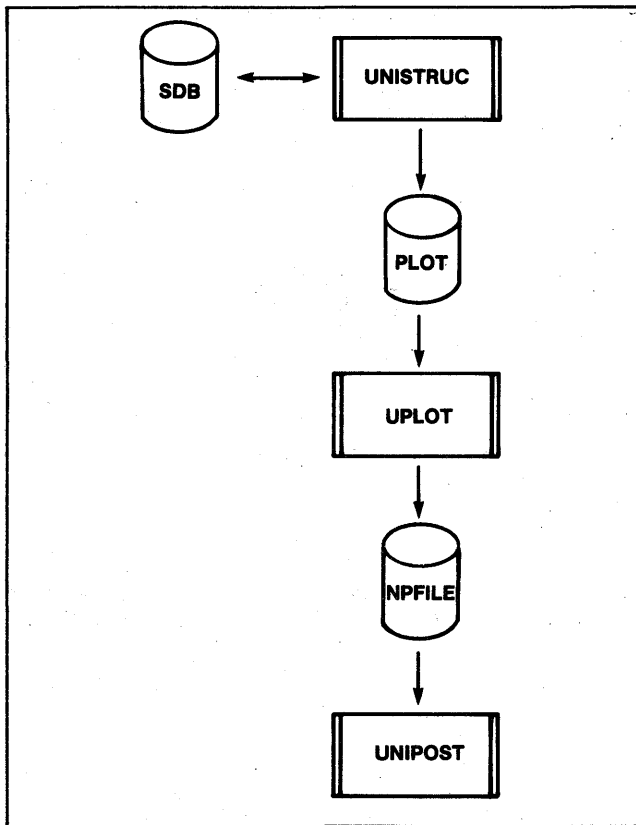

Figure UNISTRUC II-13. UNISTRUC Offline Plotting Interface

UPDATE BANNERS

When any program of the UNISTRUC system is executed, it issues a banner which includes the date on which the current version was created. The current dates for the various programs are:

UNISTRUC II	15OCT82
DIGIT	15OCT82
ANSIN	09OCT81
NASTIN	20JAN82
STARIN	15OCT82
ANSOUT	26MAR82
NASTOUT	17MAR81
STAROUT	10NOV80
UBULK	20JAN82
NBULK	09OCT81
SBULK	15OCT82
UPLOTIN	15OCT82
UPLOTM	15OCT82

KNOWN DEFICIENCIES

The following problems have been identified in UBULK of the UNISTRUC II system, but remain to be corrected.

- When updating an existing structural data base (SDB), a node entry will overwrite an existing node with the same number in the SDB, even if the OVERWRITE parameter has not been specified.
- When an element is added, all nodes in its connectivity also must be entered in the data file. If the element should reference nodes in an existing SDB which is being updated, the geometry for those nodes must be reentered.

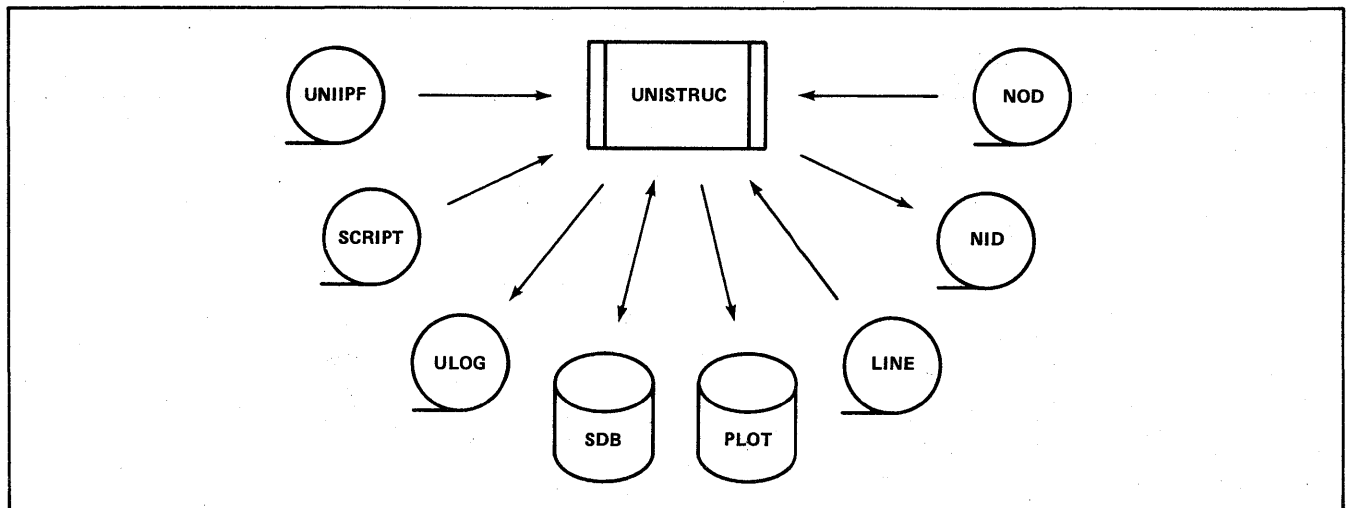

Figure UNISTRUC II-14. UNISTRUC File Usage

COMMENT SHEET

MANUAL TITLE: CDC NOS 2 Application Installation Handbook

PUBLICATION NO.: 84002760

REVISION: C

NAME: _____

COMPANY: _____

STREET ADDRESS: _____

CITY: _____ STATE: _____ ZIP CODE: _____

This form is not intended to be used as an order blank. Control Data Corporation welcomes your evaluation of this manual. Please indicate any errors, suggested additions or deletions, or general comments below (please include page number references).

Please Reply

No Reply Necessary

CUT ALONG LINE

AA3419 REV. 4/79 PRINTED IN U.S.A.

NO POSTAGE STAMP NECESSARY IF MAILED IN U.S.A.

FOLD

FOLD



NO POSTAGE
NECESSARY
IF MAILED
IN THE
UNITED STATES

BUSINESS REPLY MAIL
FIRST CLASS PERMIT NO. 8241 MINNEAPOLIS, MINN.

POSTAGE WILL BE PAID BY
CONTROL DATA CORPORATION
Publications and Graphics Division
ARH219
4201 North Lexington Avenue
Saint Paul, Minnesota 55112



CUT ALONG LINE

FOLD

FOLD